

High-Reliability CMOS 32-Word x 8-Bit Static Random-Access Memory

March 1997

Features

- Access Time
 - 610ns..... at $V_{DD} = 5V$
 - 320ns..... at $V_{DD} = 10V$
- No Precharge or Clock Required

Ordering Information

5V	10V	PACK-AGE	TEMP. RANGE	PKG. NO.
CDP1824CD3	CDP1824D3	SBDIP	-55°C to +125°C	D18.3

Description

The CDP1824/3 and CDP1824C/3 types are high-reliability CMOS 32-word x 8-bit fully static random-access memories for use in CDP1800-series microprocessor systems. These parts are compatible with the CDP1802 microprocessor and will interface directly without additional components.

The CDP1824/3 is fully decoded and does not require a pre-charge or clocking signal for proper operation. It has common input and output and is operated from a single voltage supply. The MRD signal (output disable control) enables the three-state output drivers, and overrides the MWR signal. A CS input is provided for memory expansion.

The CDP1824C/3 is functionally identical to the CDP1824/3. The CDP1824/3 has a recommended operating voltage range of 4V to 10.5V, and the CDP1824C/3 has an operating voltage range of 4V to 6.5V.

Pinout

CDP1824/3, CDP1824C/3 (SBDIP)
TOP VIEW

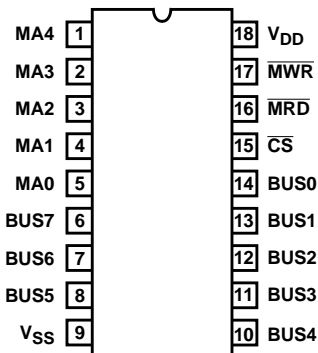

Functional Diagram

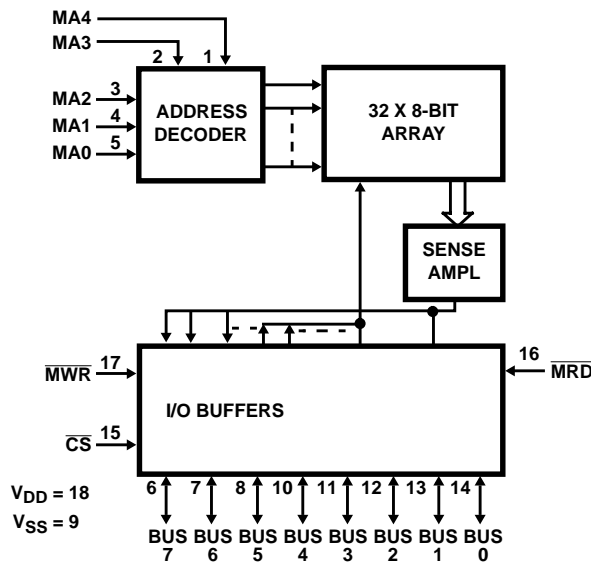

OPERATIONAL MODES

FUNCTION	CS	MRD	MWR	DATA PINS STATUS
READ	0	0	X	Output: High/Low Dependent on Data
WRITE	0	1	0	Input: Output Disabled
Not Selected	1	X	X	Output Disabled: High-Impedance State
Standby	0	1	1	Output Disabled: High-Impedance State

Logic 1 = High Logic 0 = Low X = Don't Care

CDP1824/3, CDP1824C/3

Absolute Maximum Ratings

DC Supply Voltage Range, (V_{DD}) (All Voltages Referenced to V_{SS} Terminal)	
CDP1824/3	-0.5V to +11V
CDP1824C/3	-0.5 to +7V
Input Voltage Range, All Inputs	-0.5V to V_{DD} +0.5V
DC Input Current, Any One Input	± 10 mA

Thermal Information

Thermal Resistance (Typical, Note 1)	θ_{JA} ($^{\circ}\text{C}/\text{W}$)	θ_{JC} ($^{\circ}\text{C}/\text{W}$)
SBDIP Package	75	20
Device Dissipation Per Output Transistor		
T_A = Full Package Temperature Range (All Package Types)	100mW	
Operating Temperature Range (T_A)		
Package Type D	-55 $^{\circ}\text{C}$ to +125 $^{\circ}\text{C}$	
Storage Temperature Range (T_{STG})	-65 $^{\circ}\text{C}$ to +150 $^{\circ}\text{C}$	
Lead Temperature (During Soldering)		
At distance 1/16 \pm 1/32 In. (1.59 \pm 0.79mm)		
from case for 10s max	+265 $^{\circ}\text{C}$	

Recommended Operating Conditions

T_A = Full Package-Temperature Range. For maximum reliability, nominal operating conditions should be selected so that operation is always within the following ranges:

PARAMETER	LIMITS				UNITS
	CDP1824/3		CDP1824C/3		
	MIN	MAX	MIN	MAX	
DC Operating Voltage Range	4	10.5	4	6.5	V
Input Voltage Range	V_{SS}	V_{DD}	V_{SS}	V_{DD}	V

Static Electrical Specifications

PARAMETER	SYMBOL	CONDITIONS			LIMITS				UNITS
		V_O (V)	V_{IN} (V)	V_{DD} (V)	-55 $^{\circ}\text{C}$, +25 $^{\circ}\text{C}$		+125 $^{\circ}\text{C}$		
					MIN	MAX	MIN	MAX	
Quiescent Device Current (Note 1)	I_{DD}	-	0, 5	5	-	50	-	500	μA
		-	0, 10	10	-	500	-	1000	μA
Output Voltage Low-Level (Note 2)	V_{OL}	-	0, 5	5	-	0.1	-	0.2	V
		-		10	-	0.1	-	0.2	V
Output Voltage High-Level (Note 2)	V_{OH}	-	0, 5	5	4.9	-	4.8	-	V
		-	-	10	9.9	-	4.8	-	V
Input Low Voltage	V_{IL}	0.5, 4.5	-	5	-	1.5	-	1.5	V
		1, 9	-	10	-	3	-	-	V
Input High Voltage	V_{IH}	0.5, 4.5	-	5	3.5	-	3.5	-	V
		1, 9	-	10	7	-	7	-	V
Output Low Drive (Sink) Current	I_{OL}	0.4	0, 5	5	4	-	1.5	-	mA
		0.5	0, 10	10	4	-	2.9	-	mA
Output High Drive (Source) Current	I_{OH}	4.6	0, 5	5	-	-1	-	-0.75	mA
		9.5	0, 10	10	-	-2	-	-1.5	mA
Input Current	I_{IN}	Any Input	0, 5	5	-	1	-	5	μA
			0, 10	10	-	1	-	5	μA
Three-State Output Leakage Current	I_{OUT}	0, 5	0, 5	5	-	2	-	5	μA
		0, 10	0, 10	10	-	2	-	5	μA
Input Capacitance	C_{IN}	(Note 2)			-	10	-	10	pF
Output Capacitance	C_{OUT}	(Note 2)			-	15	-	15	pF

NOTES:

- The CDP1824C/3 meets all 5V Static Electrical Characteristics of the CDP1824/3 except Quiescent Device Current for which the limits are $I_{DD} = 200\mu\text{A}$ at +25 $^{\circ}\text{C}$ /-55 $^{\circ}\text{C}$; $I_{DD} = 1000\mu\text{A}$ at +125 $^{\circ}\text{C}$.
- Guaranteed, but not tested.

CDP1824/3, CDP1824C/3

Read Cycle Dynamic Electrical Specifications Input $t_R, t_F \leq 15\text{ns}$, $C_L = 50\text{pF}$

PARAMETER	SYMBOL	TEST CONDITIONS	LIMITS				UNITS
			-55°C, +25°C		+125°C		
		V_{DD} (V)	MIN	MAX	MIN	MAX	
Access Time From Address Change	t_{AA}	5	-	610	-	825	ns
		10	-	320	-	375	ns
Access Time From Chip Select	t_{DOA}	5	-	610	-	825	ns
		10	-	320	-	375	ns
Output Active From MRD	t_{AM}	5	-	610	-	825	ns
		10	-	320	-	375	ns

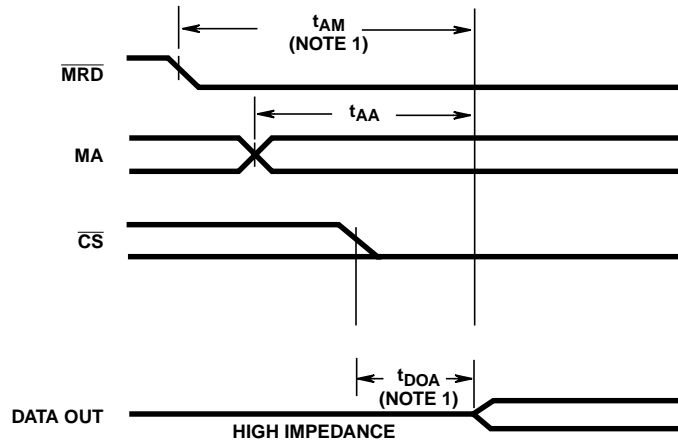

NOTE:

1. Minimum timing for valid data output longer times will initiate an earlier, but invalid output.

FIGURE 1. READ CYCLE TIMING DIAGRAM

CDP1824/3, CDP1824C/3

Write Cycle Dynamic Electrical Specifications Input $t_R, t_F \leq 15\text{ns}$, $C_L = 50\text{pF}$

PARAMETER	SYMBOL	TEST CONDITIONS V_{DD} (V)	LIMITS				UNITS
			-55°C, +25°C		+125°C		
			(NOTE 1) MIN	MAX	(NOTE 1) MIN	MAX	
Write Pulse Width	t_{WRW}	5	350	-	475	-	ns
		10	180	-	220	-	ns
Data Setup Time	t_{DS}	5	400	-	560	-	ns
		10	190	-	260	-	ns
Data Hold Time	t_{DH}	5	70	-	90	-	ns
		10	35	-	45	-	ns
Chip Select Setup Time	t_{CS}	5	550	-	775	-	ns
		10	340	-	475	-	ns
Address Setup Time	t_{AS}	5	550	-	775	-	ns
		10	340	-	475	-	ns

NOTE:

1. Time required by a device to allow for the indicated function.

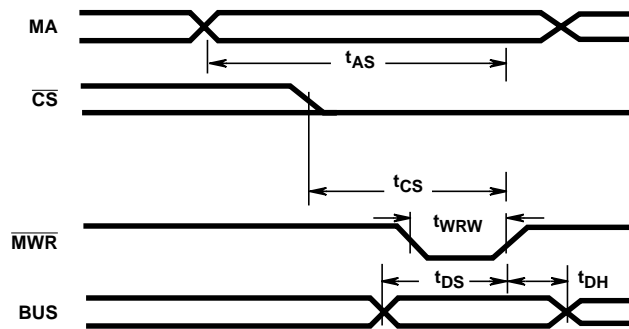

FIGURE 2. WRITE CYCLE TIMING DIAGRAM

All Intersil semiconductor products are manufactured, assembled and tested under **ISO9000** quality systems certification.

Intersil products are sold by description only. Intersil Corporation reserves the right to make changes in circuit design and/or specifications at any time without notice. Accordingly, the reader is cautioned to verify that data sheets are current before placing orders. Information furnished by Intersil is believed to be accurate and reliable. However, no responsibility is assumed by Intersil or its subsidiaries for its use; nor for any infringements of patents or other rights of third parties which may result from its use. No license is granted by implication or otherwise under any patent or patent rights of Intersil or its subsidiaries.

For information regarding Intersil Corporation and its products, see web site <http://www.intersil.com>

CDP1824/3, CDP1824C/3

Data Retention Specifications At $T_A = +25^\circ\text{C}$

PARAMETER	SYMBOL	TEST CONDITIONS		LIMITS				UNITS
				CDP1824/3		CDP1824C/3		
		V_{DR} (V)	V_{DD} (V)	MIN	MAX	MIN	MAX	
Data Retention Voltage	V_{DR}	-	-	2.5	-	2.5	-	V
Data Retention Quiescent Current	I_{DD}	2.5	-	-	10	-	40	μA
Chip Deselect to Data Retention Time	t_{CDR}	2.5	5	600	-	600	-	ns
		2.5	10	300	-	-	-	ns
Recovery to Normal Operation Time	t_{RC}	2.5	5	600	-	600	-	ns
		2.5	10	300	-	-	-	ns

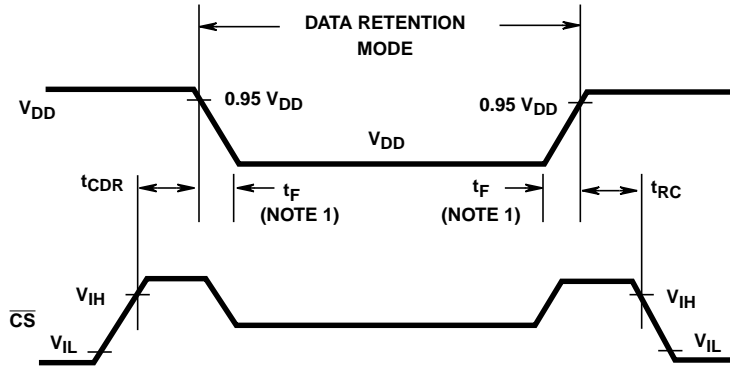

NOTE: $t_r, t_f > 1\mu\text{s}$.

FIGURE 3. LOW V_{DD} DATA RETENTION WAVEFORMS AND TIMING DIAGRAM

Static Burn-In Circuit

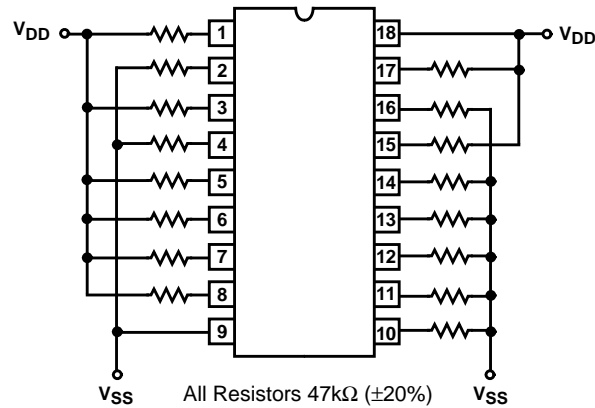

TYPE	V_{DD}	TEMPERATURE	TIME
CDP1824	11V	$+125^\circ\text{C}$	160 Hrs., Min.
CDP1824C	7V	$+125^\circ\text{C}$	160 Hrs., Min.

This datasheet has been downloaded from:

www.DatasheetCatalog.com

Datasheets for electronic components.