

**VOLTAGE RANGE: 50 --- 1000 V**

**CURRENT: 15.0 A**



### Features

- ◇ Rating to 1000V PRV
- ◇ Surge overload rating to 300 Amperes peak
- ◇ Ideal for printed circuit board
- ◇ Reliable low cost construction utilizing molded plastic technique results in inexpensive product
- ◇ Lead solderable per MIL-STD-202 method 208

**MP**

**MP - W**

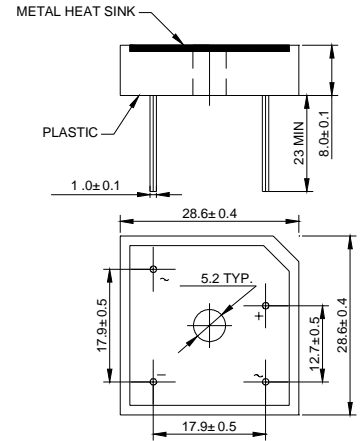
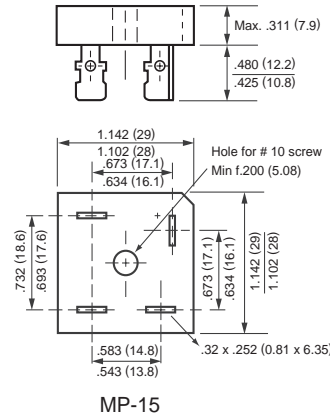

Dimensions in millimeters

### MAXIMUM RATINGS AND ELECTRICAL CHARACTERISTICS

Ratings at 25°C ambient temperature unless otherwise specified.

Single phase, half wave, 60 Hz, resistive or inductive load. For capacitive load, derate by 20%.

		MP 15005 (W)	MP 1501 (W)	MP 1502 (W)	MP 1504 (W)	MP 1506 (W)	MP 1508 (W)	MP 1510 (W)	UNITS
Maximum recurrent peak reverse voltage	$V_{RRM}$	50	100	200	400	600	800	1000	V
Maximum RMS voltage	$V_{RMS}$	35	70	140	280	420	560	700	V
Maximum DC blocking voltage	$V_{DC}$	50	100	200	400	600	800	1000	V
Maximum average forward Output current @ $T_A=25^\circ C$	$I_{F(AV)}$	15.0							A
Peak forward surge current 8.3ms single half-sine-wave superimposed on rated load	$I_{FSM}$	300.0							A
$I^2t$ Rating for fusing @ $T_j=25^\circ C$	$I^2t$	11 11							A <sup>2</sup> S
Maximum instantaneous forward voltage at 7.50 A	$V_F$	1.1							V
Maximum reverse current @ $T_A=25^\circ C$ at rated DC blocking voltage @ $T_A=100^\circ C$	$I_R$	10.0 1.0							$\mu A$ mA
Typical thermal resistance per leg	$R_{\theta JA}$ $R_{\theta JC}$	19 2							$^\circ C/W$
Operating junction temperature range	$T_J$	- 55 ---- + 150							$^\circ C$
Storage temperature range	$T_{STG}$	- 55 ---- + 150							$^\circ C$

## Ratings AND Characteristic Curves

**FIG.1 – PEAK FORWARD SURGE CURRENT**

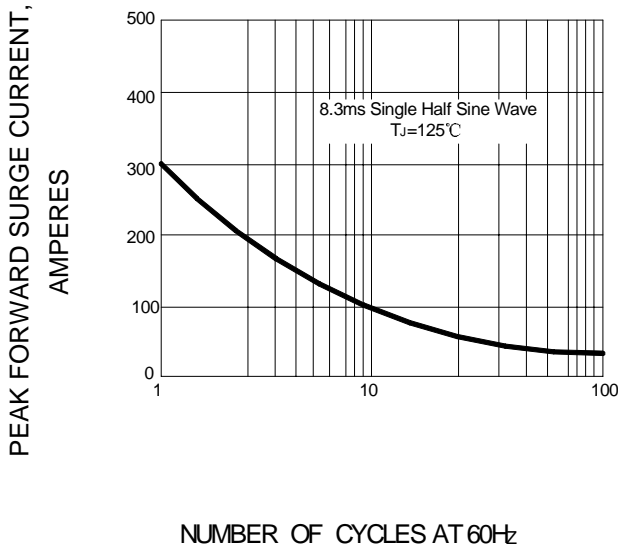

**FIG.2 – FORWARD DERATING CURVE**

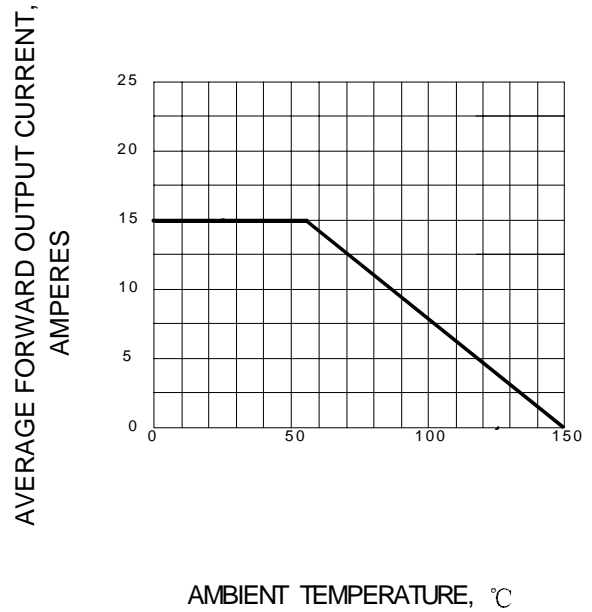

**FIG.3 – TYPICAL FORWARD CHARACTERISTIC**

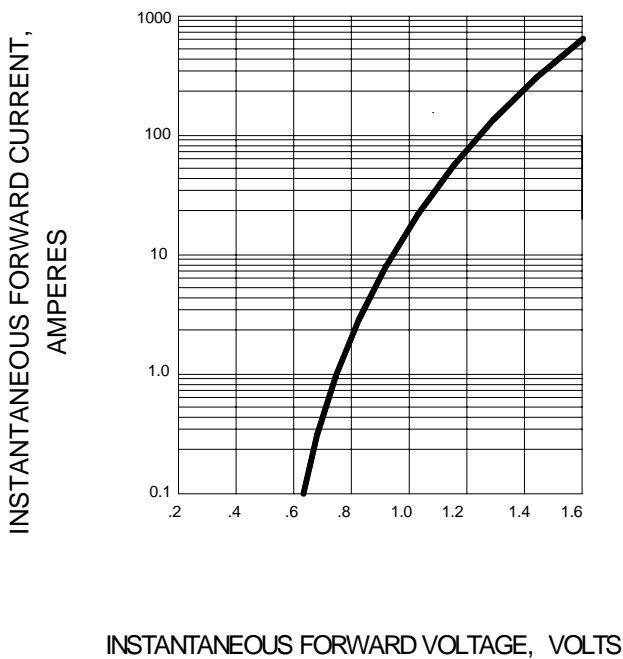

**FIG.4 – TYPICAL REVERSE CHARACTERISTICS**

