

2.7-V TO 5.5-V LOW-POWER 12-BIT DIGITAL-TO-ANALOG CONVERTERS WITH INTERNAL REFERENCE AND POWER DOWN

FEATURES

- 12-Bit Voltage Output DAC
- Programmable Internal Reference
- Programmable Settling Time vs Power Consumption
 - 1 μ s in Fast Mode
 - 3.5 μ s in Slow Mode
- Compatible With TMS320
- Differential Nonlinearity . . . <0.5 LSB Typ
- Voltage Output Range . . . 2x the Reference Voltage
- Monotonic Over Temperature

DW OR PW PACKAGE
(TOP VIEW)

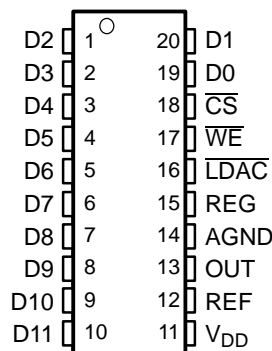

APPLICATIONS

- Digital Servo Control Loops
- Digital Offset and Gain Adjustment
- Industrial Process Control
- Machine and Motion Control Devices
- Mass Storage Devices

DESCRIPTION

The TLV5639 is a 12-bit voltage output digital-to-analog converter (DAC) with a microprocessor compatible parallel interface. It is programmed with a 16-bit data word containing 4 control and 12 data bits. Developed for a wide range of supply voltages, the TLV5639 can be operated from 2.7 V to 5.5 V.

The resistor string output voltage is buffered by a x2 gain rail-to-rail output buffer. The buffer features a Class AB output stage to improve stability and reduce settling time. The programmable settling time of the DAC allows the designer to optimize speed versus power dissipation. Because of its ability to source up to 1 mA, the internal reference can also be used as a system reference. With its on-chip programmable precision voltage reference, the TLV5639 simplifies overall system design. The settling time and the reference voltage can be chosen by the control bits within the 16-bit data word.

Implemented with a CMOS process, the device is designed for single supply operation from 2.7 V to 5.5 V. It is available in 20-pin SOIC and TSSOP packages in standard commercial and industrial temperature ranges.

AVAILABLE OPTIONS

T _A	PACKAGE	
	SOIC (DW)	TSSOP (PW)
0°C to 70°C	TLV5639CDW	TLV5639CPW
-40°C to 85°C	TLV5639IDW	TLV5639IPW



Please be aware that an important notice concerning availability, standard warranty, and use in critical applications of Texas Instruments semiconductor products and disclaimers thereto appears at the end of this data sheet.



These devices have limited built-in ESD protection. The leads should be shorted together or the device placed in conductive foam during storage or handling to prevent electrostatic damage to the MOS gates.

FUNCTIONAL BLOCK DIAGRAM

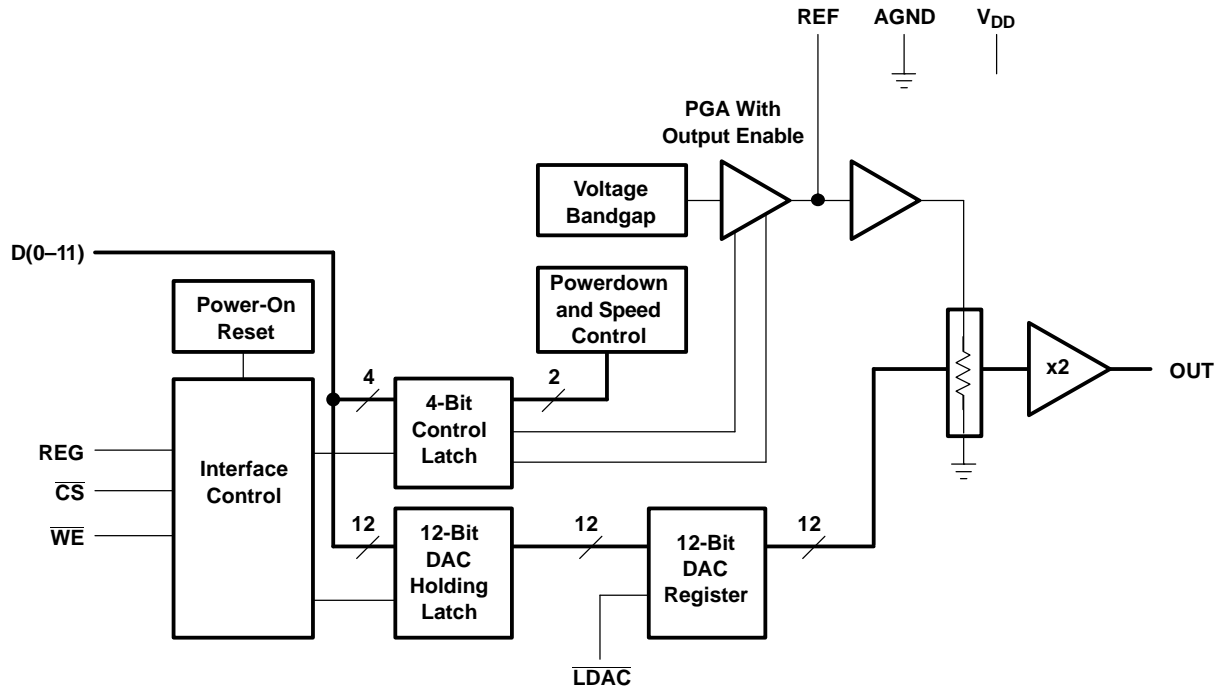

Terminal Functions

TERMINAL NAME	NO.	I/O/P	DESCRIPTION
AGND	14	P	Ground
\overline{CS}	18	I	Chip select. Digital input active low, used to enable/disable inputs
D0-D11	1-10, 19, 20	I	Data input
\overline{LDAC}	16	I	Load DAC. Digital input active low, used to load DAC output
OUT	13	O	DAC analog voltage output
REG	15	I	Register select. Digital input, used to access control register
REF	12	I/O	Analog reference voltage input/output
V_{DD}	11	P	Positive power supply
\overline{WE}	17	I	Write enable. Digital input active low, used to latch data

ABSOLUTE MAXIMUM RATINGS

over operating free-air temperature range (unless otherwise noted) ⁽¹⁾

		UNIT
Supply voltage (V_{DD} to AGND)		7 V
Reference input voltage range		- 0.3 V to $V_{DD} + 0.3$ V
Digital input voltage range		- 0.3 V to $V_{DD} + 0.3$ V
Operating free-air temperature range, T_A	TLV5639C	0°C to 70°C
	TLV5639I	-40°C to 85°C
Storage temperature range, T_{stg}		-65°C to 150°C
Lead temperature 1,6 mm (1/16 inch) from case for 10 seconds		260°C

(1) Stresses beyond those listed under *absolute maximum ratings* may cause permanent damage to the device. These are stress ratings only, and functional operation of the device at these or any other conditions beyond those indicated under *recommended operating conditions* is not implied. Exposure to absolute-maximum-rated conditions for extended periods may affect device reliability.

RECOMMENDED OPERATING CONDITIONS

		MIN	NOM	MAX	UNIT
Supply voltage, V_{DD}	$V_{DD} = 5$ V	4.5	5	5.5	V
	$V_{DD} = 3$ V	2.7	3	3.3	V
Power on threshold voltage, POR		0.55		2	V
High-level digital input voltage, V_{IH}	$V_{DD} = 2.7$ V	2			V
	$V_{DD} = 5.5$ V	2.4			
Low-level digital input voltage, V_{IL}	$V_{DD} = 2.7$ V			0.6	V
	$V_{DD} = 5.5$ V			1	
Reference voltage, V_{ref} to REF terminal	$V_{DD} = 5$ V ⁽¹⁾	AGND	2.048	$V_{DD}-1.5$	V
Reference voltage, V_{ref} to REF terminal	$V_{DD} = 3$ V ⁽¹⁾	AGND	1.024	$V_{DD}-1.5$	V
Load resistance, R_L		2			k Ω
Load capacitance, C_L				100	pF
Operating free-air temperature, T_A	TLV5639C	0		70	°C
	TLV5639I	40		85	

(1) Due to the x2 output buffer, a reference input voltage $\geq V_{DD}/2$ causes clipping of the transfer function. The output buffer of the internal reference must be disabled, if an external reference is used.

ELECTRICAL CHARACTERISTICS

over operating free-air temperature range (unless otherwise noted)

POWER SUPPLY									
PARAMETER		TEST CONDITIONS			MIN	TYP	MAX	UNIT	
I _{DD}	Power supply current	No load, All inputs = AGND or V _{DD} , DAC latch = 0x800	V _{DD} = 5 V	REF on	Fast	2.3	2.8	mA	
					Slow	1.3	1.6	mA	
				REF off	Fast	1.9	2.4	mA	
					Slow	0.9	1.2	mA	
				V _{DD} = 3 V	REF on	Fast	2.1	2.6	mA
					Slow	1.2	1.5	mA	
			REF off		Fast	1.8	2.3	mA	
					Slow	0.9	1.1	mA	
Power down supply current					0.01	1	μA		
PSRR	Power supply rejection ratio	Zero scale, External reference ⁽¹⁾			60		dB		
		Full scale, External reference ⁽²⁾			60				

(1) Power supply rejection ratio at zero scale is measured by varying V_{DD} and is given by:

$$PSRR = 20 \log [(E_{ZS}(V_{DDmax}) - E_{ZS}(V_{DDmin})) / V_{DDmax}]$$

(2) Power supply rejection ratio at full scale is measured by varying V_{DD} and is given by:

$$PSRR = 20 \log [(E_G(V_{DDmax}) - E_G(V_{DDmin})) / V_{DDmax}]$$

STATIC DAC SPECIFICATIONS								
PARAMETER		TEST CONDITIONS			MIN	TYP	MAX	UNIT
Resolution					12			bits
INL	Integral nonlinearity, end point adjusted	R _L = 10 kΩ, C _L = 100 pF, See note ⁽¹⁾			±1.2		±3	LSB
DNL	Differential nonlinearity	R _L = 10 kΩ, C _L = 100 pF, See note ⁽²⁾			±0.3		±0.5	LSB
E _{ZS}	Zero-scale error (offset error at zero scale)	See note ⁽³⁾					±12	LSB
E _{ZS} TC	Zero-scale-error temperature coefficient	See note ⁽⁴⁾			20			ppm/°C
E _G	Gain error	See note ⁽⁵⁾					±0.3	% full scale V
E _G TC	Gain error temperature coefficient	See note ⁽⁶⁾			20			ppm/°C

(1) The relative accuracy or integral nonlinearity (INL) sometimes referred to as linearity error, is the maximum deviation of the output from the line between zero and full scale excluding the effects of zero code and full-scale errors (see text).

(2) The differential nonlinearity (DNL) sometimes referred to as differential error, is the difference between the measured and ideal 1 LSB amplitude change of any two adjacent codes. Monotonic means the output voltage changes in the same direction (or remains constant) as a change in the digital input code.

(3) Zero-scale error is the deviation from zero voltage output when the digital input code is zero (see text).

(4) Zero-scale-error temperature coefficient is given by: $E_{ZS} TC = [E_{ZS}(T_{max}) - E_{ZS}(T_{min})] / 2V_{ref} \times 10^6 / (T_{max} - T_{min})$.

(5) Gain error is the deviation from the ideal output (2V_{ref} - 1 LSB) with an output load of 10 k excluding the effects of the zero-error.

(6) Gain temperature coefficient is given by: $E_G TC = [E_G(T_{max}) - E_G(T_{min})] / 2V_{ref} \times 10^6 / (T_{max} - T_{min})$.

OUTPUT SPECIFICATIONS								
PARAMETER		TEST CONDITIONS			MIN	TYP	MAX	UNIT
V _O	Output voltage	R _L = 10 kΩ			V _{DD} -0.4			V
Output load regulation accuracy		V _O = 4.096 V, 2.048 V, R _L = 2 kΩ			±0.29			% full scale V

ELECTRICAL CHARACTERISTICS

over operating free-air temperature range (unless otherwise noted)

REFERENCE PIN CONFIGURED AS OUTPUT (REF)							
PARAMETER	TEST CONDITIONS	MIN	TYP	MAX	UNIT		
$V_{ref(OUTL)}$	Low reference voltage	1.003	1.024	1.045	V		
$V_{ref(OUTH)}$	High reference voltage	$V_{DD} > 4.75\text{ V}$		2.027	2.048	2.069	V
$I_{ref(source)}$	Output source current				1	mA	
$I_{ref(sink)}$	Output sink current	1			mA		
PSRR	Power supply rejection ratio	48			dB		

REFERENCE PIN CONFIGURED AS INPUT (REF)						
PARAMETER	TEST CONDITIONS	MIN	TYP	MAX	UNIT	
V_I	Input voltage	0	$V_{DD} - 1.5$		V	
R_I	Input resistance	10			M Ω	
C_I	Input capacitance	5			pF	
Reference input bandwidth	REF = 0.2 V_{pp} + 1.024 V dc	Fast	900		kHz	
		Slow	500			
Harmonic distortion, reference input	REF = 1 V_{pp} + 2.048 V dc, $V_{DD} = 5\text{ V}$	10 kHz	Fast	87		dB
			Slow	77		
		50 kHz	Fast	74		dB
			Slow	61		
		100 kHz	Fast	66		dB
		Reference feedthrough	REF = 1 V_{pp} at 1 kHz + 1.024 V dc, See ⁽¹⁾	80		

(1) Reference feedthrough is measured at the DAC output with an input code = 0x000.

DIGITAL INPUTS						
PARAMETER	TEST CONDITIONS	MIN	TYP	MAX	UNIT	
I_{IH}	High-level digital input current	$V_I = V_{DD}$		1	μA	
I_{IL}	Low-level digital input current	$V_I = 0\text{ V}$		1	μA	
C_i	Input capacitance	8			pF	

OPERATING CHARACTERISTICS

over recommended operating free-air temperature range, $V_{ref} = 2.048\text{ V}$, and $V_{ref} = 1.024\text{ V}$, (unless otherwise noted)

ANALOG OUTPUT DYNAMIC PERFORMANCE							
PARAMETER		TEST CONDITIONS		MIN	TYP	MAX	UNIT
$t_{s(FS)}$	Output settling time, full scale	$R_L = 10\text{ k}\Omega$, $C_L = 100\text{ pF}$, see note (1)	Fast		1	3	μs
			Slow		3.5	7	
$t_{s(CC)}$	Output settling time, code to code	$R_L = 10\text{ k}\Omega$, $C_L = 100\text{ pF}$, see note (2)	Fast		0.5	1.5	μs
			Slow		1	2	
SR	Slew rate	$R_L = 10\text{ k}\Omega$, $C_L = 100\text{ pF}$, see note (3)	Fast	6	10		$\text{V}/\mu\text{s}$
			Slow	1.2	1.7		
Glitch energy		DIN = 0 to 1, $f_{CLK} = 100\text{ kHz}$, $\overline{CS} = V_{DD}$			5		$\text{nV}\cdot\text{S}$
SNR	Signal-to-noise ratio	$f_s = 480\text{ kSPS}$, $f_B = 20\text{ kHz}$, $C_L = 100\text{ pF}$ $f_{out} = 1\text{ kHz}$, $R_L = 10\text{ k}\Omega$		73	78		dB
SINAD	Signal-to-noise + distortion			61	67		
THD	Total harmonic distortion				69	62	
SFDR	Spurious free dynamic range			63	74		

- (1) Settling time is the time for the output signal to remain within ± 0.5 LSB of the final measured value for a digital input code change of $0x020$ to $0xFDF$ or $0xFDF$ to $0x020$.
- (2) Settling time is the time for the output signal to remain within ± 0.5 LSB of the final measured value for a digital input code change of one count.
- (3) Slew rate determines the time it takes for a change of the DAC output from 10% to 90% full-scale voltage.

DIGITAL INPUT TIMING REQUIREMENTS

		MIN	NOM	MAX	UNIT
$t_{su(CS-WE)}$	Setup time, \overline{CS} low before negative \overline{WE} edge	15			ns
$t_{su(D)}$	Setup time, data ready before positive \overline{WE} edge	10			ns
$t_{su(R)}$	Setup time, REG ready before positive \overline{WE} edge	20			ns
$t_{h(DR)}$	Hold time, data and REG held valid after positive \overline{WE} edge	5			ns
$t_{su(WE-LD)}$	Setup time, positive \overline{WE} edge before \overline{LDAC} low	5			ns
$t_{wH(WE)}$	Pulse duration, \overline{WE} high	20			ns
$t_{w(LD)}$	Pulse duration, \overline{LDAC} low	23			ns

PARAMETER MEASUREMENT INFORMATION

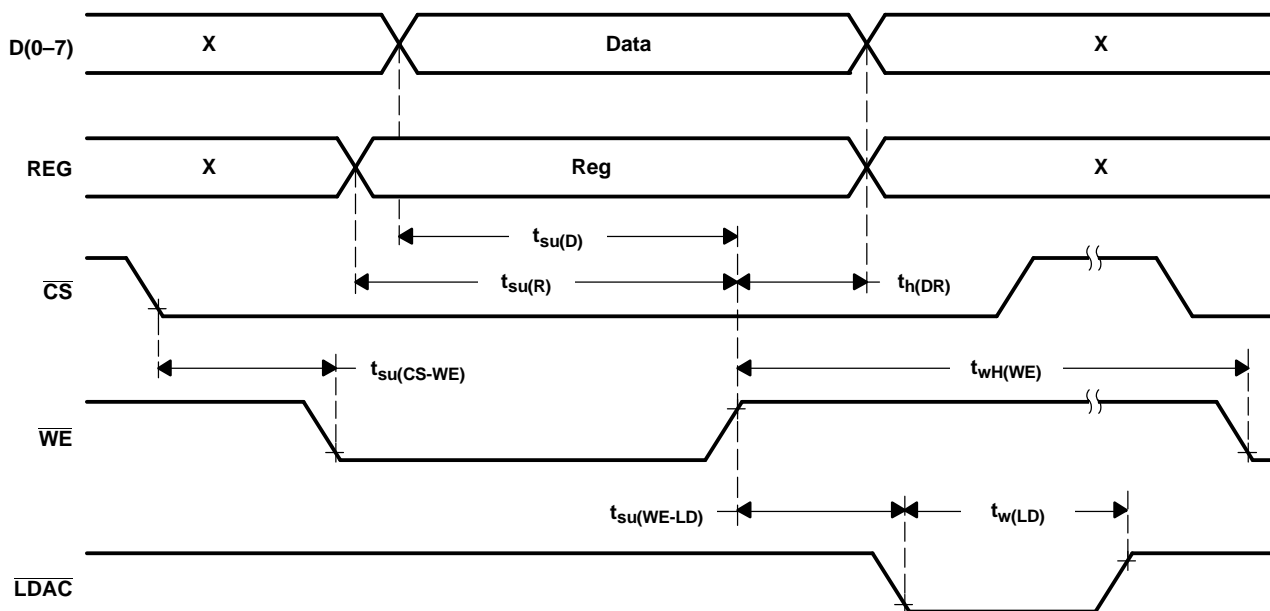

Figure 1. Timing Diagram

TYPICAL CHARACTERISTICS
DIFFERENTIAL NONLINEARITY ERROR

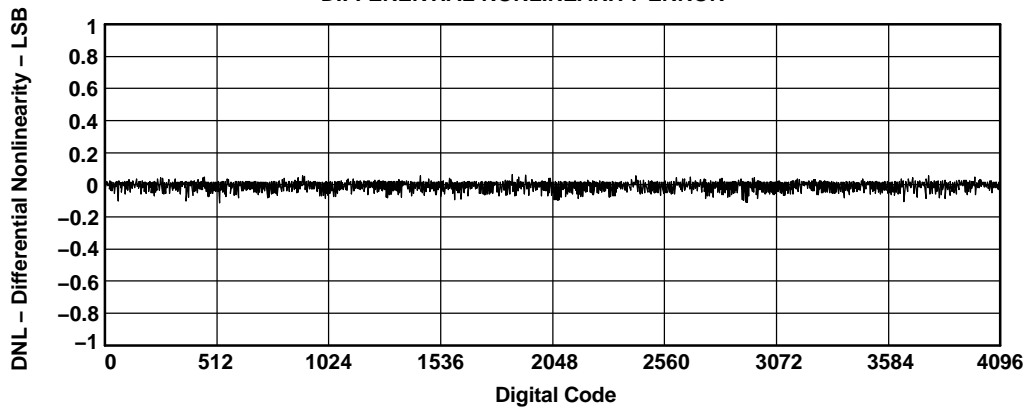

Figure 2.

INTEGRAL NONLINEARITY ERROR

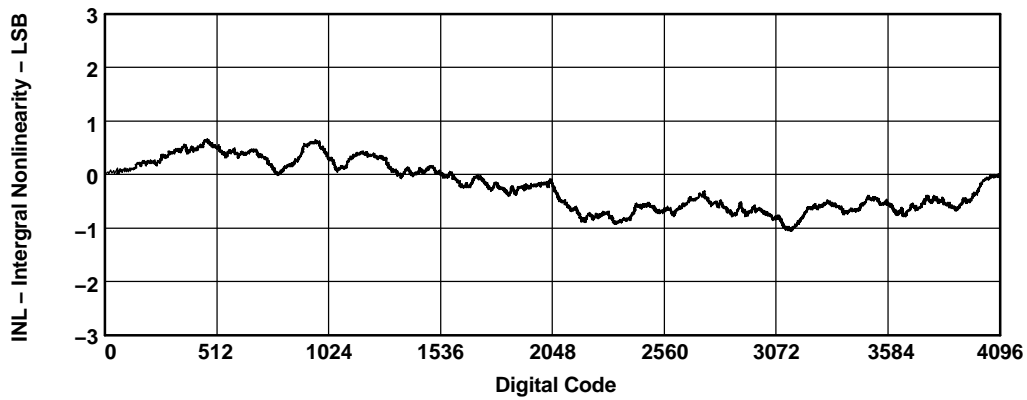

Figure 3.

TYPICAL CHARACTERISTICS (continued)

MAXIMUM OUTPUT VOLTAGE
vs
LOAD CURRENT

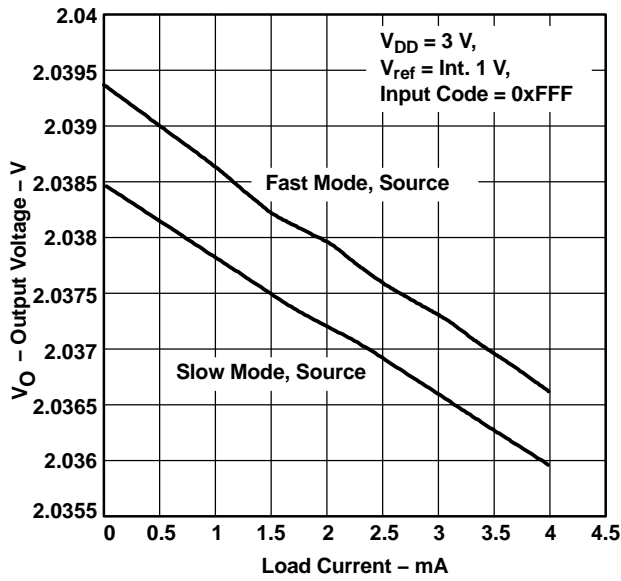

Figure 4.

MAXIMUM OUTPUT VOLTAGE
vs
LOAD CURRENT

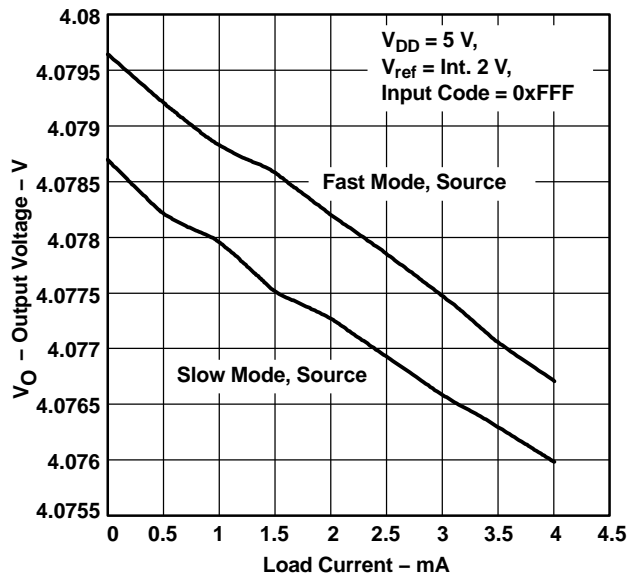

Figure 5.

MINIMUM OUTPUT VOLTAGE
vs
LOAD CURRENT

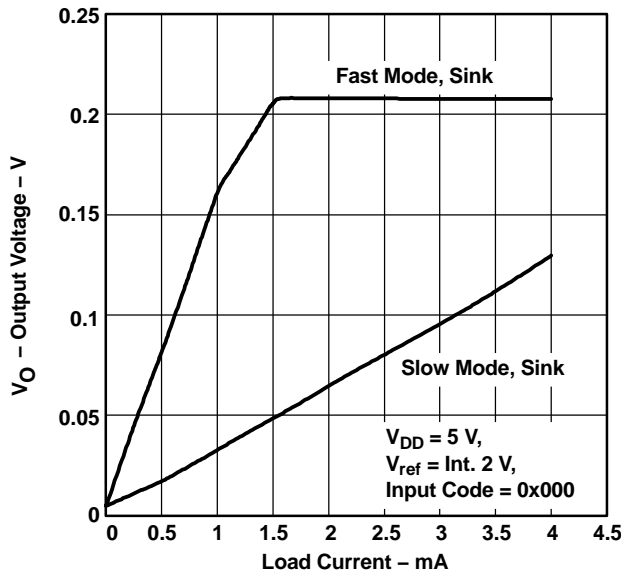

Figure 6.

MINIMUM OUTPUT VOLTAGE
vs
LOAD CURRENT

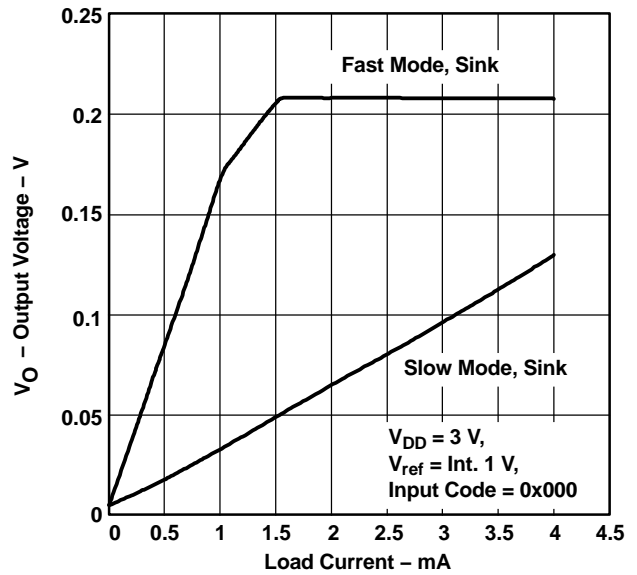

Figure 7.

TYPICAL CHARACTERISTICS (continued)

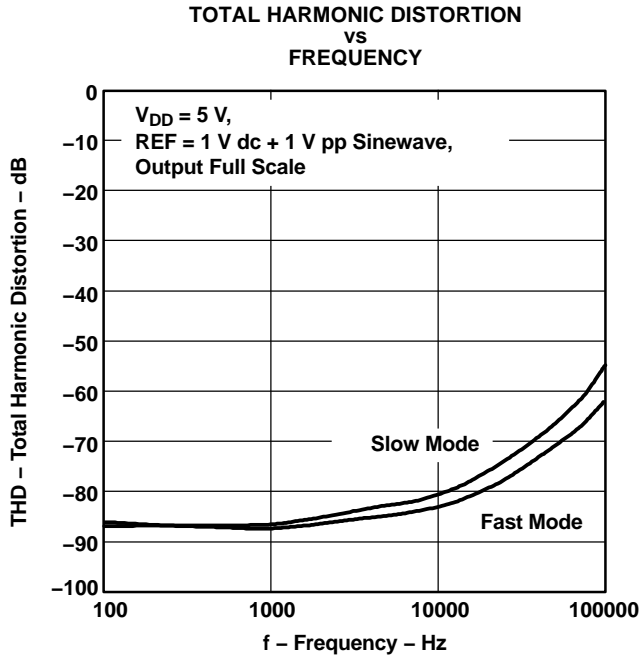

Figure 8.

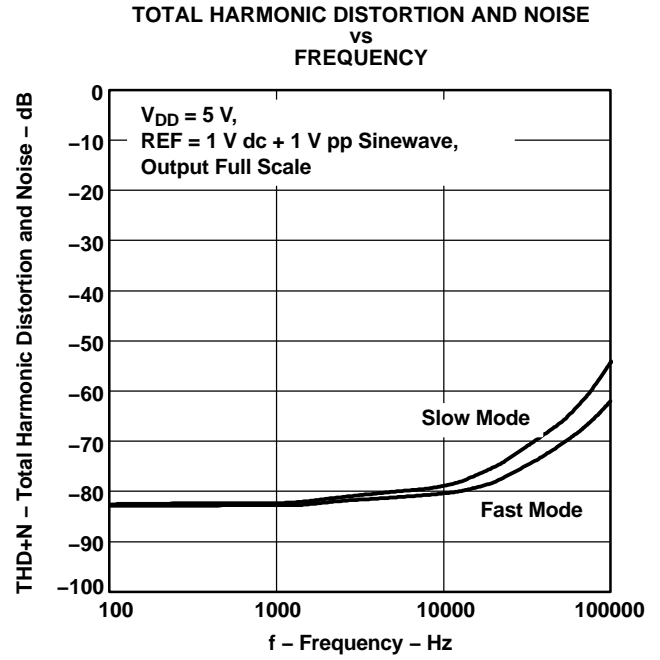

Figure 9.

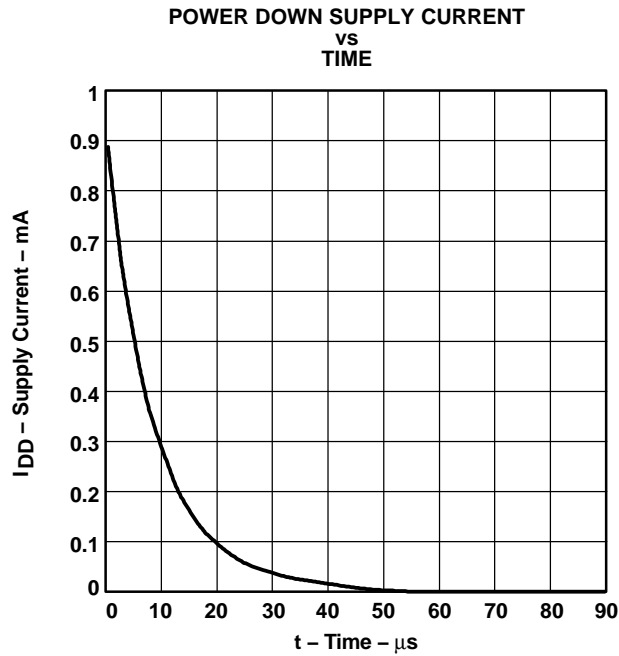

Figure 10.

APPLICATION INFORMATION

GENERAL FUNCTION

The TLV5639 is a 12-bit, single supply DAC, based on a resistor string architecture. It consists of a parallel interface, a speed and power down control logic, a programmable internal reference, a resistor string, and a rail-to-rail output buffer. The output voltage (full scale determined by reference) is given by:

$$2 \text{ REF } \frac{\text{CODE}}{0x1000} \text{ [V]}$$

Where REF is the reference voltage and CODE is the digital input value in the range 0x000 to 0xFFFF. A power-on reset initially puts the internal latches to a defined state (all bits zero).

PARALLEL INTERFACE

The device latches data on the positive edge of $\overline{\text{WE}}$. It must be enabled with $\overline{\text{CS}}$ low. Whether the data is written to the DAC holding latch or the control register depends on REG. REG = 0 selects the DAC holding latch, REG = 1 selects the control register. $\overline{\text{LDAC}}$ low updates the DAC with the value in the holding latch. $\overline{\text{LDAC}}$ is an asynchronous input and can be held low, if a separate update is not necessary. However, to control the DAC using the load feature, there should be approximately a 5 ns delay after the positive $\overline{\text{WE}}$ edge before driving $\overline{\text{LDAC}}$ low.

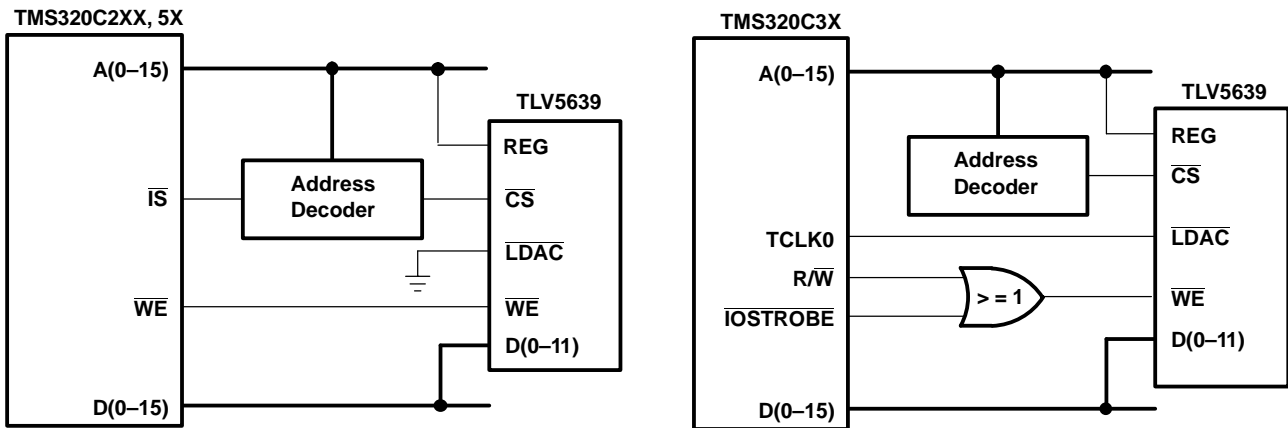

Figure 11.

DATA FORMAT

The TLV5639 writes data either to the DAC holding latch or to the control register, depending on the level of the REG input.

Data destination:

REG = 0 → DAC holding latch

REG = 1 → control register

APPLICATION INFORMATION (continued)

The following table lists the meaning of the bits within the control register:

D11	D10	D9	D8	D7	D6	D5	D4	D3	D2	D1	D0
X	X	X	X	X	X	X	REF1	REF0	X	PWR	SPD
X ⁽¹⁾	X ⁽¹⁾	X ⁽¹⁾	X ⁽¹⁾	X ⁽¹⁾	X ⁽¹⁾	X ⁽¹⁾	0 ⁽¹⁾	0 ⁽¹⁾	X ⁽¹⁾	0 ⁽¹⁾	0 ⁽¹⁾

(1) Default values

SPD : Speed control bit 1 = fast mode 0 = slow mode
PWR : Power control bit 1 = power down 0 = normal operation

REF1 and REF0 determine the reference source and the reference voltage.

REFERENCE BITS

REF1	REF0	REFERENCE
0	0	External
0	1	1.024 V
1	0	2.048 V
1	1	External

If an external reference voltage is applied to the REF pin, external reference must be selected.

LINEARITY, OFFSET, AND GAIN ERROR USING SINGLE END SUPPLIES

When an amplifier is operated from a single supply, the voltage offset can still be either positive or negative. With a positive offset, the output voltage changes on the first code change. With a negative offset the output voltage may not change with the first code depending on the magnitude of the offset voltage.

The output amplifier attempts to drive the output to a negative voltage. However, because the most negative supply rail is ground, the output cannot drive below ground and clamps the output at 0 V.

The output voltage remains at zero until the input code value produces a sufficient positive output voltage to overcome the negative offset voltage, resulting in the transfer function shown in Figure 12.

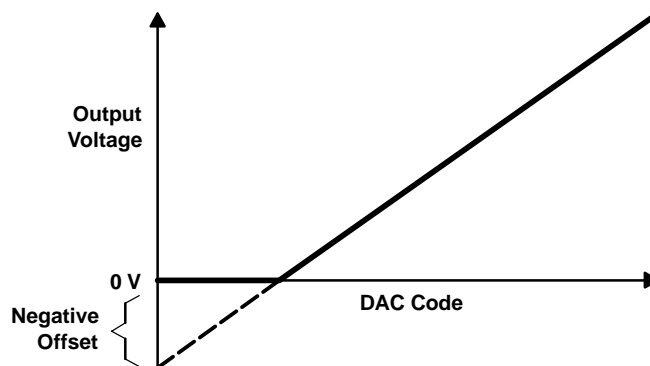

Figure 12. Effect of Negative Offset (Single Supply)

This offset error, not the linearity error, produces this breakpoint. The transfer function would have followed the dotted line if the output buffer could drive below the ground rail.

For a DAC, linearity is measured between zero input code (all inputs 0) and full scale code (all inputs 1) after offset and full scale are adjusted out or accounted for in some way. However, single supply operation does not allow for adjustment when the offset is negative due to the breakpoint in the transfer function. So the linearity is measured between full scale code and the lowest code that produces a positive output voltage.

TLV5639 INTERFACED to TMS320C203 DSP

HARDWARE INTERFACE

Figure 13 shows an example of the connection between the TLV5639 and the TMS320C203 DSP. The only other device that is needed in addition to the DSP and the DAC is the 74AC138 address decoding circuit. Using this configuration, the DAC data is at address 0x0084 and the DAC control word is at address 0x0085 within the I/O memory space of the TMS320C203.

$\overline{\text{LDAC}}$ is tied low so that the output voltage is updated on the rising $\overline{\text{WE}}$ edge.

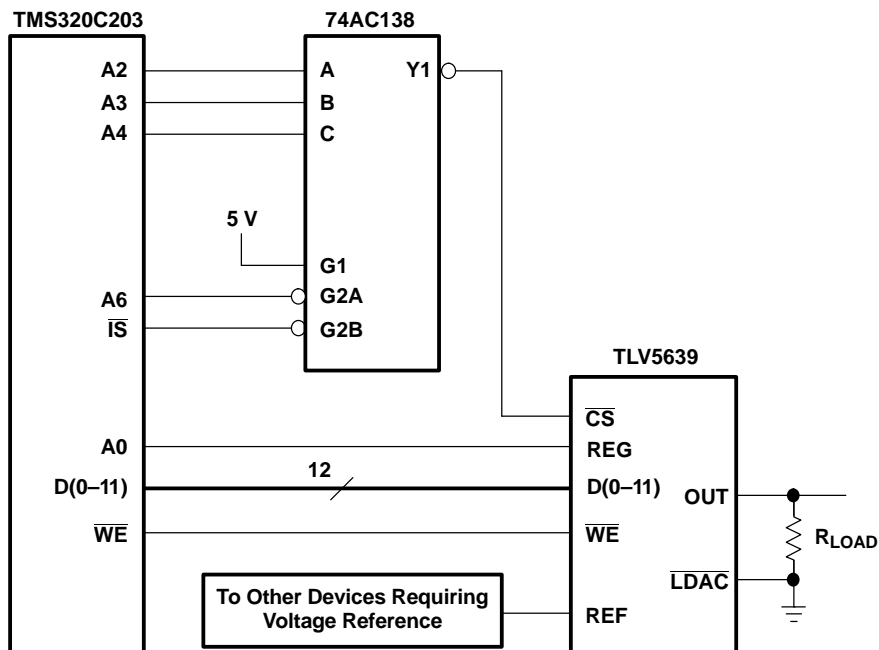

Figure 13. TLV5639 to TMS320C203 DSP Interface Connection

SOFTWARE

Writing data or control information to the TLV5639 is done using a single command. For example, the line of code which reads:

```
out 62h, dac_ctrl
```

writes the contents of address 0x0062 to the I/O address equated to dac_ctrl (0x0085, the address where the DAC control register has been mapped).

The following code shows how to set the DAC up to use the internal reference and operate in FAST mode by a write to the control register. Timer interrupts are then enabled and repeatedly generated every 205 μs to provide a timebase for synchronizing the waveform generation. In this example, the waveform is generated by simply incrementing a counter and outputting the counter value to the DAC data word once every timer interrupt. This results in a saw waveform.

```
; File:          RAMP.ASM
; Function:      ramp generation with TLV5639
; Processors:   TMS320C203
; { 1999 Texas Instruments

;----- I/O and memory mapped regs -----
        .include regs.asm
dac_data
.equ
0084h
dac_ctrl
.equ
0085h
;----- vectors -----
        .ps
0h

b
start
        b
INT1
        b
INT23
        b
TIM_ISR

-----Main Program-----
        .ps
1000h
        .entry
start:
        ldp
#0
; set data page to 0
; disable interrupts
        setc
INTM
; disable maskable interrupts
        splk
#0ffffh, IFR
        splk
#0004h, IMR

; set up the timer
        splk
#0000h, 60h
        splk
#0042h, 61h

out
61h, PRD
        out
60h, TIM

splk
#0c2fh, 62h
        out
62h, TCR

        splk
#0011h, 62h ; set up the DAC
; SPD=1 (FAST mode) and ; REF1=1 (2.048 V internal ref enable)
        out
```

62h, dac_ctrl

 clrc
INTM ; enable interrupts

; loop forever!
next
 idle
b next

----- Interrupt Service Routines-----

INT1:
 ret
; do nothing and return
INT23:
 ret
; do nothing and return
TIM_ISR:
; timer interrupt handler
 add
#1h
; increment accumulator

sacl
60h
 out
60h, dac_data ; write to DAC
 clrc
intm
 ; re-enable interrupts
 ret
 ; return from interrupt
 .END

PACKAGING INFORMATION

Orderable Device	Status (1)	Package Type	Package Drawing	Pins	Package Qty	Eco Plan (2)	Lead finish/ Ball material (6)	MSL Peak Temp (3)	Op Temp (°C)	Device Marking (4/5)	Samples
TLV5639CDW	ACTIVE	SOIC	DW	20	25	RoHS & Green	NIPDAU	Level-1-260C-UNLIM	0 to 70	TLV5639C	Samples
TLV5639CPW	ACTIVE	TSSOP	PW	20	70	RoHS & Green	NIPDAU	Level-1-260C-UNLIM	0 to 70	TV5639	Samples
TLV5639IDW	ACTIVE	SOIC	DW	20	25	RoHS & Green	NIPDAU	Level-1-260C-UNLIM	-40 to 85	TLV5639I	Samples
TLV5639IPW	ACTIVE	TSSOP	PW	20	70	RoHS & Green	NIPDAU	Level-1-260C-UNLIM	-40 to 85	TY5639	Samples
TLV5639IPWR	ACTIVE	TSSOP	PW	20	2000	RoHS & Green	NIPDAU	Level-1-260C-UNLIM	-40 to 85	TY5639	Samples

(1) The marketing status values are defined as follows:

ACTIVE: Product device recommended for new designs.

LIFEBUY: TI has announced that the device will be discontinued, and a lifetime-buy period is in effect.

NRND: Not recommended for new designs. Device is in production to support existing customers, but TI does not recommend using this part in a new design.

PREVIEW: Device has been announced but is not in production. Samples may or may not be available.

OBSELETE: TI has discontinued the production of the device.

(2) **RoHS:** TI defines "RoHS" to mean semiconductor products that are compliant with the current EU RoHS requirements for all 10 RoHS substances, including the requirement that RoHS substance do not exceed 0.1% by weight in homogeneous materials. Where designed to be soldered at high temperatures, "RoHS" products are suitable for use in specified lead-free processes. TI may reference these types of products as "Pb-Free".

RoHS Exempt: TI defines "RoHS Exempt" to mean products that contain lead but are compliant with EU RoHS pursuant to a specific EU RoHS exemption.

Green: TI defines "Green" to mean the content of Chlorine (Cl) and Bromine (Br) based flame retardants meet JS709B low halogen requirements of <=1000ppm threshold. Antimony trioxide based flame retardants must also meet the <=1000ppm threshold requirement.

(3) MSL, Peak Temp. - The Moisture Sensitivity Level rating according to the JEDEC industry standard classifications, and peak solder temperature.

(4) There may be additional marking, which relates to the logo, the lot trace code information, or the environmental category on the device.

(5) Multiple Device Markings will be inside parentheses. Only one Device Marking contained in parentheses and separated by a "~" will appear on a device. If a line is indented then it is a continuation of the previous line and the two combined represent the entire Device Marking for that device.

(6) Lead finish/Ball material - Orderable Devices may have multiple material finish options. Finish options are separated by a vertical ruled line. Lead finish/Ball material values may wrap to two lines if the finish value exceeds the maximum column width.

Important Information and Disclaimer: The information provided on this page represents TI's knowledge and belief as of the date that it is provided. TI bases its knowledge and belief on information provided by third parties, and makes no representation or warranty as to the accuracy of such information. Efforts are underway to better integrate information from third parties. TI has taken and continues to take reasonable steps to provide representative and accurate information but may not have conducted destructive testing or chemical analysis on incoming materials and chemicals. TI and TI suppliers consider certain information to be proprietary, and thus CAS numbers and other limited information may not be available for release.

In no event shall TI's liability arising out of such information exceed the total purchase price of the TI part(s) at issue in this document sold by TI to Customer on an annual basis.

TAPE AND REEL INFORMATION



QUADRANT ASSIGNMENTS FOR PIN 1 ORIENTATION IN TAPE



*All dimensions are nominal

Device	Package Type	Package Drawing	Pins	SPQ	Reel Diameter (mm)	Reel Width W1 (mm)	A0 (mm)	B0 (mm)	K0 (mm)	P1 (mm)	W (mm)	Pin1 Quadrant
TLV5639IPWR	TSSOP	PW	20	2000	330.0	16.4	6.95	7.1	1.6	8.0	16.0	Q1

TAPE AND REEL BOX DIMENSIONS

*All dimensions are nominal

Device	Package Type	Package Drawing	Pins	SPQ	Length (mm)	Width (mm)	Height (mm)
TLV5639IPWR	TSSOP	PW	20	2000	350.0	350.0	43.0

PW (R-PDSO-G20)

PLASTIC SMALL OUTLINE



4040064-5/G 02/11

- NOTES:
- A. All linear dimensions are in millimeters. Dimensioning and tolerancing per ASME Y14.5M-1994.
 - B. This drawing is subject to change without notice.
 - C. Body length does not include mold flash, protrusions, or gate burrs. Mold flash, protrusions, or gate burrs shall not exceed 0,15 each side.
 - D. Body width does not include interlead flash. Interlead flash shall not exceed 0,25 each side.
 - E. Falls within JEDEC MO-153

PW (R-PDSO-G20)

PLASTIC SMALL OUTLINE



- NOTES:
- A. All linear dimensions are in millimeters.
 - B. This drawing is subject to change without notice.
 - C. Publication IPC-7351 is recommended for alternate design.
 - D. Laser cutting apertures with trapezoidal walls and also rounding corners will offer better paste release. Customers should contact their board assembly site for stencil design recommendations. Refer to IPC-7525 for other stencil recommendations.
 - E. Customers should contact their board fabrication site for solder mask tolerances between and around signal pads.

DW0020A



PACKAGE OUTLINE

SOIC - 2.65 mm max height

SOIC



4220724/A 05/2016

NOTES:

1. All linear dimensions are in millimeters. Dimensions in parenthesis are for reference only. Dimensioning and tolerancing per ASME Y14.5M.
2. This drawing is subject to change without notice.
3. This dimension does not include mold flash, protrusions, or gate burrs. Mold flash, protrusions, or gate burrs shall not exceed 0.15 mm per side.
4. This dimension does not include interlead flash. Interlead flash shall not exceed 0.43 mm per side.
5. Reference JEDEC registration MS-013.

EXAMPLE BOARD LAYOUT

DW0020A

SOIC - 2.65 mm max height

SOIC



LAND PATTERN EXAMPLE
SCALE:6X



SOLDER MASK DETAILS

4220724/A 05/2016

NOTES: (continued)

- 6. Publication IPC-7351 may have alternate designs.
- 7. Solder mask tolerances between and around signal pads can vary based on board fabrication site.

EXAMPLE STENCIL DESIGN

DW0020A

SOIC - 2.65 mm max height

SOIC



SOLDER PASTE EXAMPLE
BASED ON 0.125 mm THICK STENCIL
SCALE:6X

4220724/A 05/2016

NOTES: (continued)

8. Laser cutting apertures with trapezoidal walls and rounded corners may offer better paste release. IPC-7525 may have alternate design recommendations.
9. Board assembly site may have different recommendations for stencil design.

IMPORTANT NOTICE AND DISCLAIMER

TI PROVIDES TECHNICAL AND RELIABILITY DATA (INCLUDING DATASHEETS), DESIGN RESOURCES (INCLUDING REFERENCE DESIGNS), APPLICATION OR OTHER DESIGN ADVICE, WEB TOOLS, SAFETY INFORMATION, AND OTHER RESOURCES "AS IS" AND WITH ALL FAULTS, AND DISCLAIMS ALL WARRANTIES, EXPRESS AND IMPLIED, INCLUDING WITHOUT LIMITATION ANY IMPLIED WARRANTIES OF MERCHANTABILITY, FITNESS FOR A PARTICULAR PURPOSE OR NON-INFRINGEMENT OF THIRD PARTY INTELLECTUAL PROPERTY RIGHTS.

These resources are intended for skilled developers designing with TI products. You are solely responsible for (1) selecting the appropriate TI products for your application, (2) designing, validating and testing your application, and (3) ensuring your application meets applicable standards, and any other safety, security, or other requirements. These resources are subject to change without notice. TI grants you permission to use these resources only for development of an application that uses the TI products described in the resource. Other reproduction and display of these resources is prohibited. No license is granted to any other TI intellectual property right or to any third party intellectual property right. TI disclaims responsibility for, and you will fully indemnify TI and its representatives against, any claims, damages, costs, losses, and liabilities arising out of your use of these resources.

TI's products are provided subject to TI's Terms of Sale (www.ti.com/legal/termsofsale.html) or other applicable terms available either on ti.com or provided in conjunction with such TI products. TI's provision of these resources does not expand or otherwise alter TI's applicable warranties or warranty disclaimers for TI products.

Mailing Address: Texas Instruments, Post Office Box 655303, Dallas, Texas 75265
Copyright © 2020, Texas Instruments Incorporated