

# TB62732FUG

## Step-up DC/DC Converter for White LED Driver

The TB62732FUG is a high-efficiency step-up DC/DC converter designed and optimized for the constant-current lighting of white LEDs.

This IC is particularly suitable for illuminating two to four serial white LEDs with a Li-ion battery.

The IC incorporates an N-ch MOS transistor, which is necessary for switching of the coil.

Also, the LED current  $I_F$  can be easily set through the use of an external resistor.

The TB62732FUG is best suited for use as a driver for white LED source backlighting in color LCDs used on PDAs, cellular phones and handy terminal devices.

The suffix (G) appended to the part number represents a Lead (Pb) -Free product.

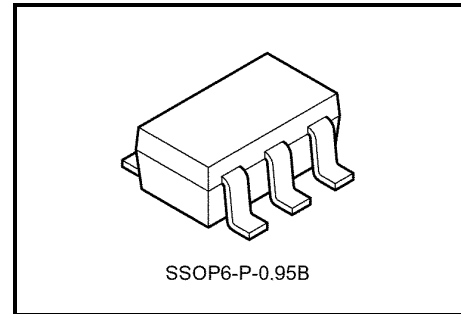

Weight: 0.016 g (typ.)

### Features

- LED current values can set through the use of an external resistor
  - 15 mA (typ.) @ $R_{sens} = 3.3 \Omega$
  - 18.5 mA (typ.) @ $R_{sens} = 2.7 \Omega$
- Efficiency of 80% realized (serial LEDs 2 to 3,  $I_F = 20$  mA)
- Maximum output voltage:  $V_o = 17$  V
- Output power: Up to 320 mW supported
- Compact package: 6-pin SOT23 (SSOP6-P-0.95B)
- Built-in N-channel MOS with low ON-resistance ( $R_{on}$ )
  - $R_{on} = 2.0 \Omega$  (typ.) @ $V_{CC} = V_{IN} = 3.6$  V
- Switching frequency: 1.1 MHz (typ.)
- Output capacitor
  - Small capacity of 0.47  $\mu$ F
- Inductance: 2.2  $\mu$ H to 10  $\mu$ H

### Pin assignment (top view)

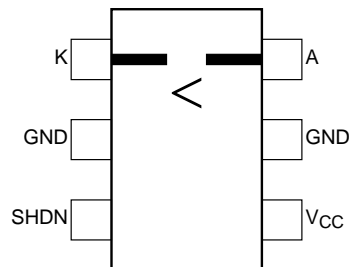

Note 1: This product contains pins that are vulnerable to electrostatic discharge. Handle with care.  
 This IC may break if mounted 180 degrees in the reverse direction. Be sure to orientate the IC in the correct direction.

## Block Diagram

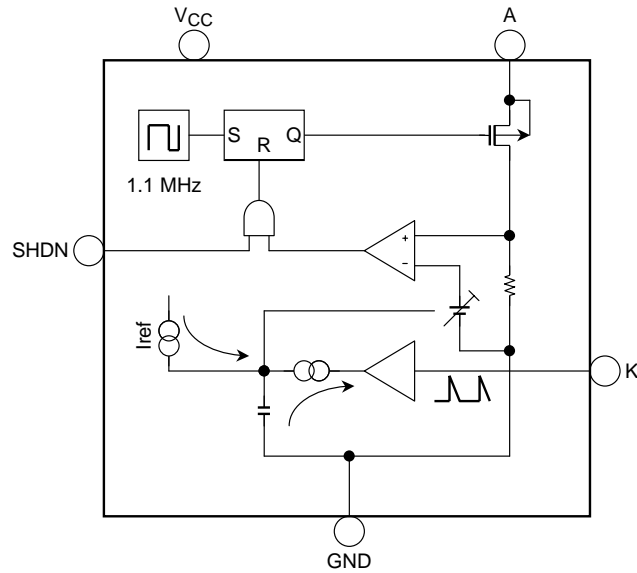

## Pin Functions

No	Symbol	Function
1	K	Pin connecting LED cathode to resistor used to set current. Feedback pin for voltage waveforms for controlling the LED constant current.
2, 5	GND	Ground pin for the logic
3	SHDN	IC enable pin. If Low, Standby Mode takes effect and pin A is turned off.
4	V <sub>CC</sub>	Input pin for power supply for operating the IC. Operating voltage range: 3.0 to 5.5 V
6	A	DC-DC converter switch pin. The switch is an N-channel MOSFET transistor.

Note 2: Connect both GND pins to ground.

## Absolute Maximum Ratings

Characteristics	Symbol	Rating	Unit
Supply voltage	$V_{CC}$	-0.3 to +6.0	V
Input voltage	$V_{IN}$	-0.3 to $+V_{CC} + 0.3$	V
Switching pin current	$I_o$ (A)	380	mA
Switching pin voltage	$V_o$ (A)	-0.3 to 17	V
Power dissipation	$P_D$	0.41 (IC only)	W
		0.47 (IC mounted on PCB) (Note 3)	
Saturation thermal resistance	$R_{th(j-a)}$	300 (IC only) 260 (IC mounted on PCB)	°C/W
Operating temperature range	$T_{opr}$	-40 to +85	°C
Storage temperature range	$T_{stg}$	-40 to +150	°C
Maximum junction temperature	$T_j$	125	°C

Note 3: The power dissipation is derated by 3.8 mW/°C from the absolute maximum rating for every 1°C exceeding the ambient temperature of 25°C (when the IC is mounted on a PCB).

## Recommended Operating Conditions (unless otherwise specified, $T_a = 25^\circ\text{C}$ and $V_{CC} = 3.6\text{ V}$ )

Characteristics	Symbol	Test circuit	Test condition	Min	Typ.	Max	Unit
Supply voltage	$V_{CC}$	—	—	3.0	—	4.3	V
SHDN pin high-level input voltage	$V_{IH}$	—	$V_{CC} = 3$ to 4.3 V	2.6	—	$V_{CC}$	V
SHDN pin low-level input voltage	$V_{IL}$	—	$V_{CC} = 3$ to 4.3 V	0	—	0.5	V
SHDN pin input pulse width	tpw SHDN	—	SHDN = High and Low level	50	—	—	μs
Set LED current	$I_o$	—	$V_{CC} = 3\text{ V}$ , illuminating series LEDs 2 to 4	5	—	20	mA

## Electrical Characteristics (unless otherwise specified, $T_a = 25^\circ\text{C}$ , $V_{CC} = 3.6\text{ V}$ , $V_{SHDN} = 3.6\text{ V}$ )

Characteristics	Symbol	Test circuit	Test condition	Min	Typ.	Max	Unit
Supply voltage	$V_{CC}$	—	—	3.0	—	5.5	V
Current consumption at operation	$I_{CC}$ (on)	—	SHDN = $V_{CC}$	—	0.52	0.8	mA
Current consumption at standby	$I_{CC}$ (off)	—	SHDN = 0 V	—	0.5	1.0	$\mu\text{A}$
SHDN pin current	$I_{SHDN}$	—	SHDN = $V_{CC}$ , Built-in pull-down resistor	—	4.2	7	$\mu\text{A}$
MOS transistor on-resistance	$R_{on}$	—	$I_o = 300\text{ mA}$ , detection resistance value is contained	—	2.0	2.5	$\Omega$
MOS transistor switching frequency	$f_{OSC}$	—	—	0.77	1.1	1.43	MHz
Pin A voltage	$V_o$ (A)	—	—	17	—	—	V
Pin A current	$I_o$ (A)	—	—	—	350	380	mA
Pin A leakage current	$I_{oz}$ (A)	—	—	—	0.5	1	$\mu\text{A}$
Set LED current $I_F$	$I_o$	—	$R_{sens} = 2.7\ \Omega$ , $L = 6.8\ \mu\text{H}$ (Note 4)	—	18.5	—	mA
LED current $V_{CC}$ dependence	$dI_o$	—		—	$\pm 8$	$\pm 12$	%

Note 4: Fluctuation in  $R_{sens}$  resistors is not included in the specified value.

The absolute value of  $I_o$  may vary and therefore differ from the value specified due to the relation between the inductor value and the load.

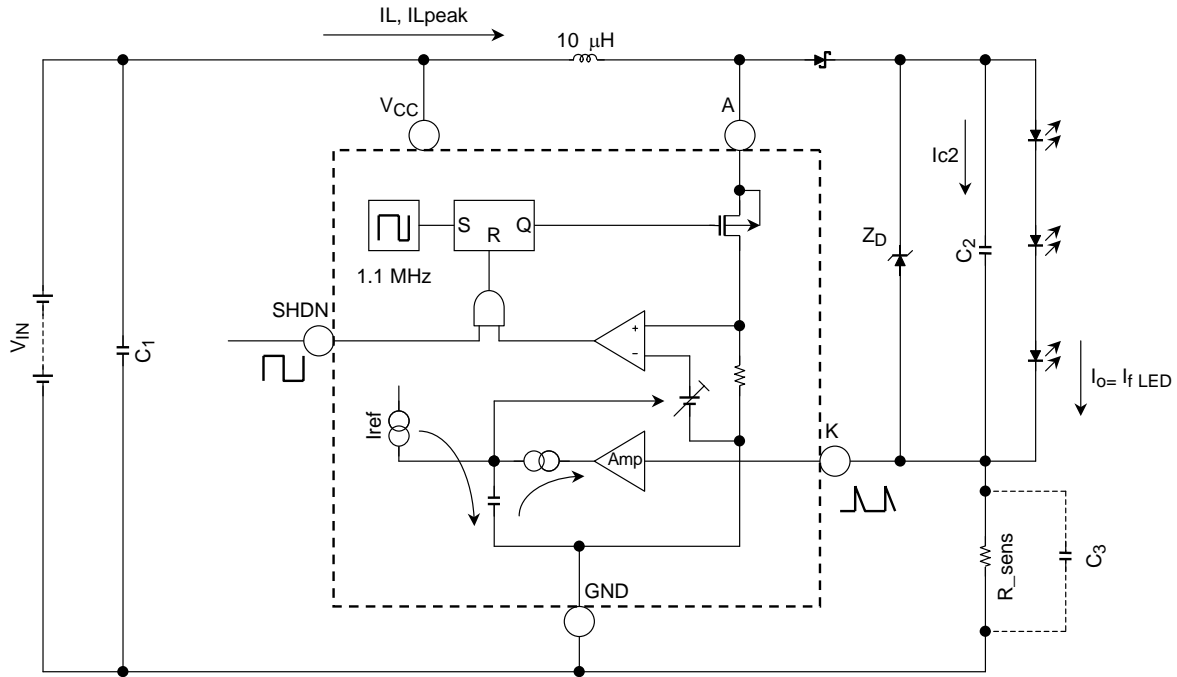

Figure 1 Application Circuit

**Basic Operation**

The basic TB62732FUG circuit uses a step-up DC/DC converter, and features peak control of the current pulse.

The inductance is turned on and off with the fixed frequency  $f_{osc}$  (1.1 MHz (typ.)), and the inductor is charged with energy.

When the inductance is turned on, the inductor current  $I_L$  increases from  $I_L = 0$ ; and when  $I_L = I_{Lpeak}$  is reached, the inductance is turned off.

At this point, the Schottky diode is turned on and  $I_L = I_{c2}$  flows so that the coil may retain  $I_L = I_{Lpeak}$ . After that,  $I_{c2}$  is decreased, and  $I_L = 0$  is reached.

This operation is repeated; and as soon as  $I_{c2}$  has fully charged  $C2$ ,  $I_o$  flows to the LED.

The details of the basic pulse used for the current control are shown in Figure 2.

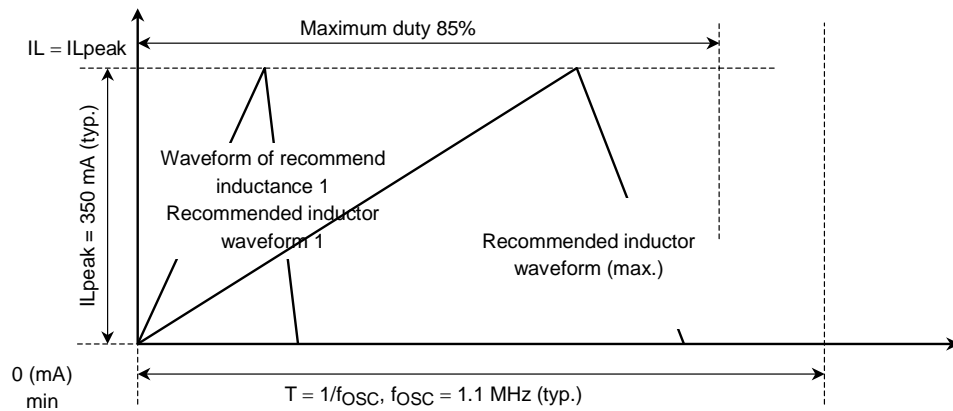

Figure 2 Switching Waveform of Inductance

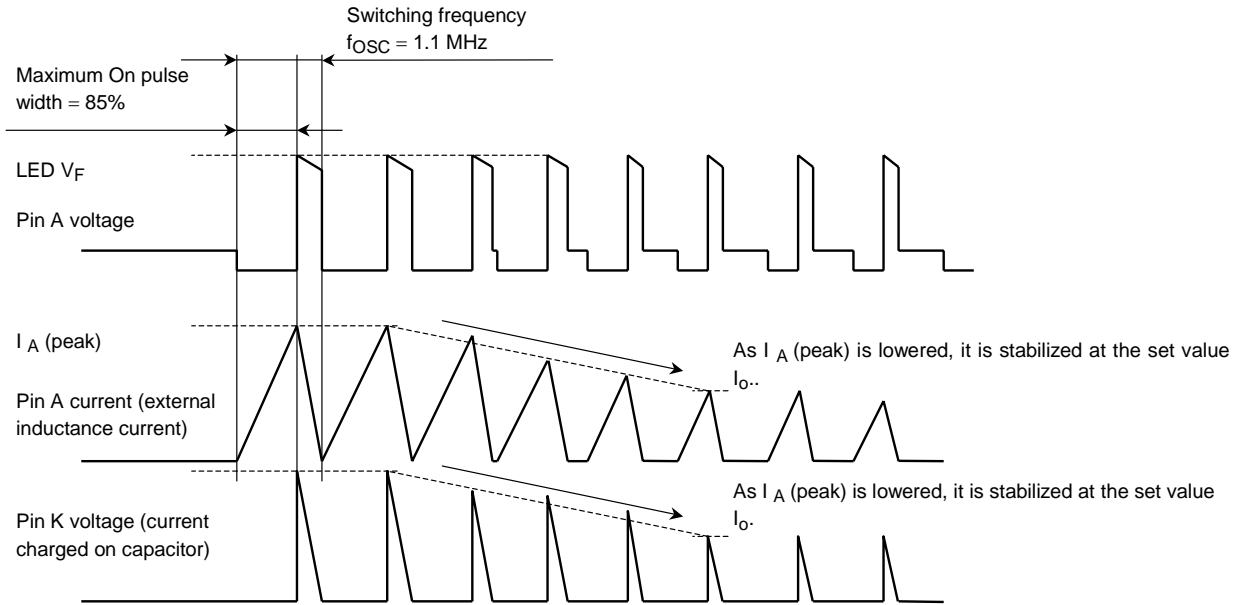

Figure 3 Burst Control Waveforms

**State of Peak Current Control**

“Peak current control” is control that can vary the peak current pulse shown in Figure 2 on the previous page. The current pulse in Figure 2 is a charging current on the output side capacitor C<sub>2</sub>. This is supplied to the LED as a C<sub>2</sub> discharge current and flows through the R<sub>sens</sub> resistor to GND.

The charging voltage wave form of C<sub>2</sub> is fed back to the IC from pin K.

In the internal circuit to which it is assumed pin K is input, the mean value of the AC voltage waveform obtained decreases the peak current to an assumed value of approximately 48 to 54 mV.

As a result, a constant current is controlled as an average current in the LED.

Therefore, if R<sub>sens</sub> = 2.7 Ω is connected, an I<sub>F</sub> current of 19.6 mA can be obtained.

The TB62732FUG is designed to be able to supply a load power of 320 mW (min.). With an inductance of 4.7 to 10 μH, the boost inductor has been optimally designed for this load power of 320 mW.

Also, make the inductance small when the load power is low.

A condition applying to the LED load between pins A and K is that

$$V_{IN} (V_{CC}) < LED V_F \text{ total}$$

should be strictly maintained.

The LED will be illuminated always regardless of the IC control. Care should be taken in this regard.

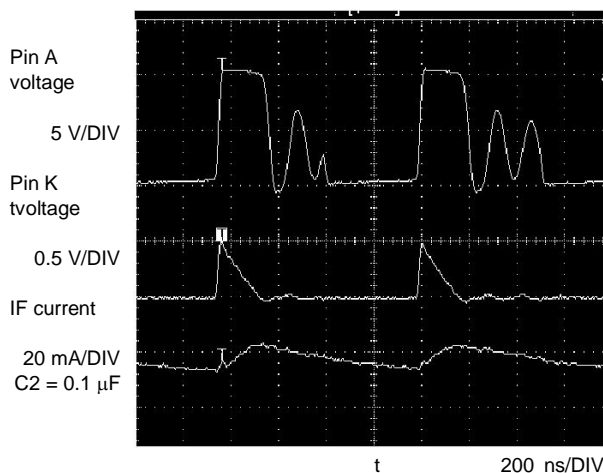

**Standby Operation**

The SHDN pin is used to set normal or standby operation. When SHDN is set to Low, operation is in standby; when the pin is High, the LED is turned on. Current consumption in Standby Mode is 1 μA (max).

**Drive Waveform**

The figure on the left is an actual drive waveform.

From the top, the switching voltage waveform of the coil of the generator terminal (pin A), the feedback voltage wave form of pin K, and the LED I<sub>F</sub>.

## Output-side capacitor setting

To reduce the effect of ripple current, we recommend  $C_2 = 0.47$  ( $\mu\text{F}$ ) or above.

Capacitor $C_2$ ( $\mu\text{F}$ )	Ripple Current (mA)	Note
0.01	15 to 25	
0.1	5 to 8	Recommend
0.47	2 to 4	
1	1 to 3	

## External inductance setting

The minimum external inductance is calculated as follows:

$$L (\mu\text{H}) = ((K \times P_o) - V_{\text{IN min}} \times I_o) \times (1/f_{\text{OSC min}}) \times 2 \times (1/I_{\text{p min}} \times I_{\text{p min}}) \dots \text{ formula 2}$$

The above parameters are described below:

$P_o$ : output power (power required by LED load)

$$P_o (\text{W}) = V_{\text{F LED}} \times I_{\text{F LED}} + V_{\text{f schottky}} \times I_{\text{F LED}} + R_{\text{sens}} \times I_{\text{F LED}} \times I_{\text{F LED}}$$

LED forward current:  $I_{\text{F LED}}$  (mA) = Set current:  $I_o$  (mA), LED forward voltage:  $V_{\text{F LED}}$  (V),

Schottky diode forward voltage:  $V_{\text{f schottky}}$  (V),

Setting resistance:  $R_{\text{sens}}$  ( $\Omega$ )

$V_{\text{IN min}}$  (V): Minimum input voltage (battery voltage)

$I_o$  (A): The average current value established with  $R_{\text{sens}}$ .

$f_{\text{OSC}}$  (Hz): The switching frequency of the internal MOS transistor

	Min	Typ.	Max	Unit
$f_{\text{OSC}}$	0.77	1.1	1.43	MHz

$I_p$  (A): Peak current value for supply to the inductance

	Min	Typ.	Max	Unit
$I_p$	320	350	380	MHz

For example, the following condition is substituted for the formula:

Input voltage  $V_{\text{IN}}$ :  $V_{\text{IN}} = 3$  to  $4.3$  V,

$V_{\text{F LED}} = 16$  V, Schottky diode  $V_{\text{f}}$ : Schottky =  $0.3$  (V),

Setup resistance  $R_{\text{sens}}$ :  $R_{\text{sens}} = 2.7$  ( $\Omega$ ),

Setup current  $I_o$ :  $I_o = 18.5$  mA,

$L$  ( $\mu\text{H}$ ) =  $5.6$  ( $\mu\text{H}$ ,  $V_{\text{IN}} = 3.0$  V) and  $6.3$  ( $\mu\text{H}$ ,  $V_{\text{IN}} = 4.3$  V).

In this case, Toshiba recommend selection of  $L = 5.6$  ( $\mu\text{H}$ ) when  $V_{\text{CC}} = 3$  V. . .  
 This value does not allow for inductor variation and temperature characteristics; therefore we strongly recommend that these factors be taken into account when selecting products.

**Selection of R\_sens**

The resistance R\_sens (Ω) between pin K and GND is used for setting the output current I<sub>o</sub>. The mean output current I<sub>o</sub> can be set using this resistance.

The mean current I<sub>o</sub> (mA) to be set is roughly calculated as follows:

$$I_o \text{ (mA)} = V \text{ (K): pin K feedback voltage (mV)} \div R_{\text{sens}} \Omega$$

Number of LEDs	Pin K voltage V (K)	Note
2	48	
3	50	
4	52	

For example, if R\_sens = 2.7 (Ω), then I<sub>o</sub> = 18.5 (mA) with a current error of ±12%.

The IC has a minimum output P<sub>o</sub> = 320 (mW).

In this case, if the product P<sub>o</sub> of the set current I<sub>F</sub> LED and the output voltage V<sub>F</sub> LED exceeds P<sub>o</sub> = 320 (mW), it is possible that the current I<sub>F</sub> LED will not exceed a given value.

If the IC is not connected to the smoothing capacitor, then I<sub>F</sub> LED is obtained as the mean current.

In this instance, because the current which flows to the LED is a triangular waveform current with a maximum peak value of 380 mA, make sure that the inrush current I<sub>FP</sub> (mA) does not flow to the LED.

Toshiba recommend use of components with low reactance (parasitic inductance) and minimized PCB wiring.

**Protection for when the LED is open**

The zener diode in the example application circuit in Figure 1 is necessary for over-voltage protection when the LED is open.

It is strongly recommended that a zener diode be connected since this driver lacks a voltage protection circuit.

The zener voltage should satisfy the following conditions:

- i) ≤ maximum output voltage of the TB62732FUG
- ii) ≥ LED aggregate V<sub>f</sub>
- iii) ≤ maximum output capacitance C<sub>2</sub>.

Moreover, it is possible to control the output current I<sub>ZD</sub> for when the LED is open by connecting the R\_ZD as in Figure 4, and to use a zener diode with lower power dissipation.

*Standard for Control of Output Current I<sub>ZD</sub> through R\_ZD Connection*  
(R\_sens = 2.7 Ω)

R_DZ (Ω)	I <sub>ZD</sub> (mA)
18	3
100	0.1

Since driver characteristics may be adversely affected, Toshiba recommend 100 Ω or less.

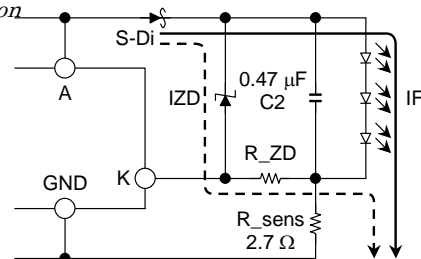

**Figure 4 Application Circuit**



Current consumption at normal operation  $I_{CC} (ON)$

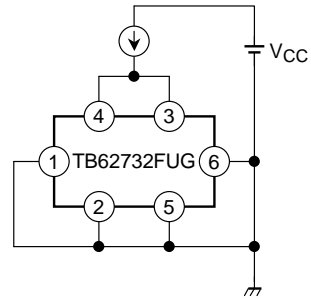
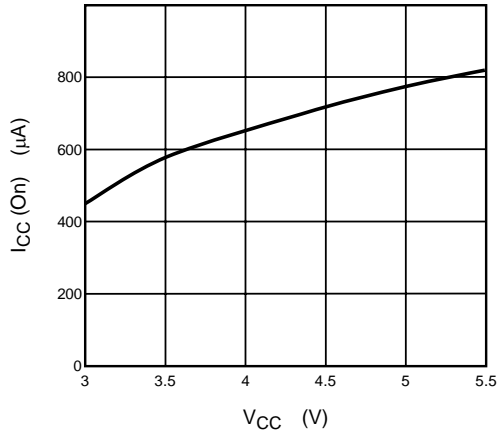

Current consumption at shutdown  $I_{CC} (SHDN)$

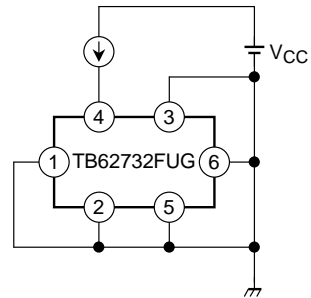
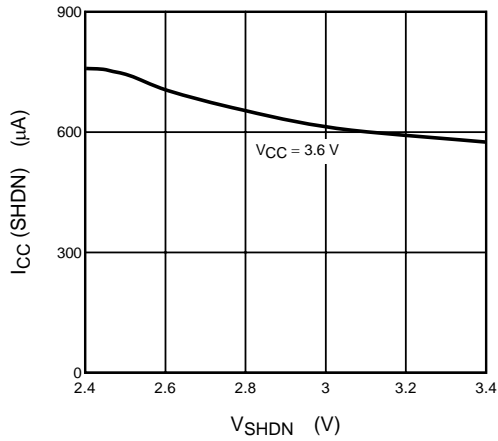

Output switching frequency

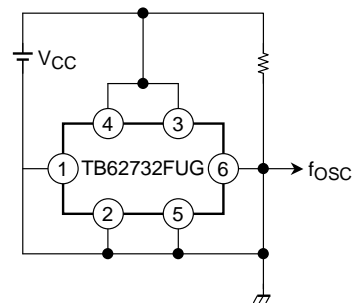
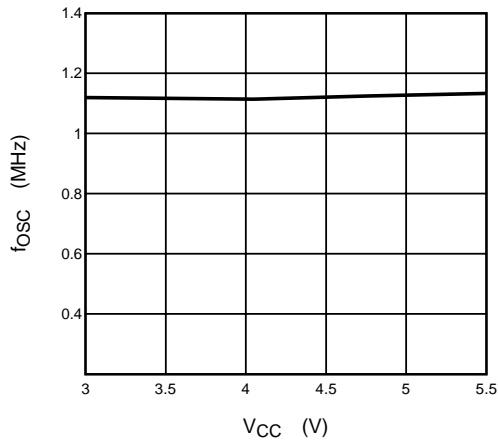

## Application Evaluation Circuit Example 1 (Example of evaluation result using a small coil: Coil LDR304612T-6R8)

6.8  $\mu\text{H}$  is optimum for illuminating serial LEDs 3 to 4 LEDs using  $I_F = 20 \text{ mA}$ .

4.7  $\mu\text{H}$  is recommended for steady illumination of serial LED 2 in the range  $V_{IN} > 4.5 \text{ V}$ .

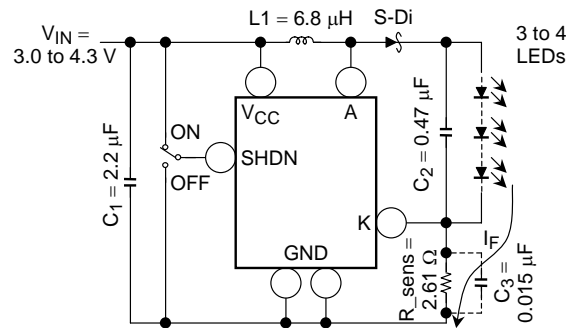

L1 : TDK LDR304612T-6R8  
S-Di: TOSHIBA CUS02 30 V/1 A  
LED: NICHIA NSCW215T

Note 5: Connection of  $C_3$  is not necessary in every case.

The  $I_F$  is expected to stabilize on the increase of voltage.

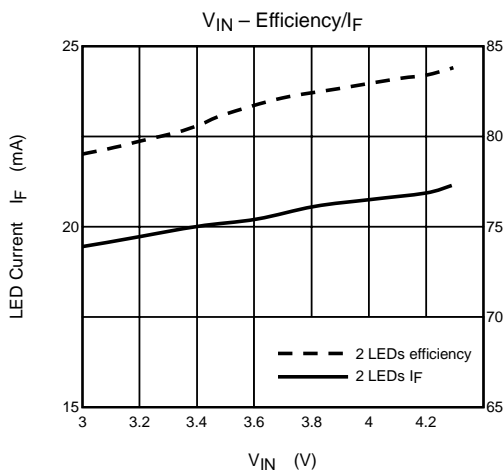
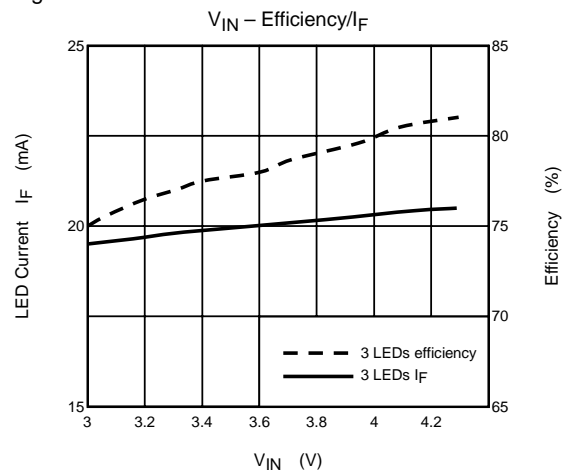
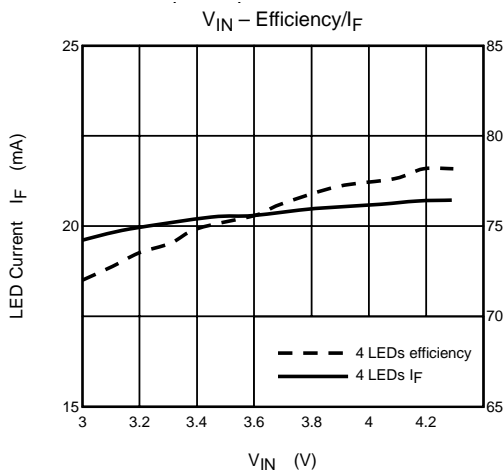

<Measurement>

Efficiency in the range  $V_{IN} = 3.0$  to  $4.3 \text{ V}$

Number of LED	Efficiency (%)	Average Efficiency (%)
2	79.0 to 83.8	81.6
3	75.1 to 80.9	78.3
4	72.0 to 78.3	75.7

$I_F$  in the range  $V_{IN} = 3.0$  to  $4.3 \text{ V}$

Number of LED	$I_F$ (mA)	$V_{CC}$ Dependence (%)
2	19.5 to 21.1	7.8
3	19.5 to 20.5	4.9
4	19.6 to 20.7	5.3

Note 6: The above values have been obtained through Toshiba's own measurements. However, results may vary according to the measurement environment.

## Application Evaluation Circuit Example 2 (Example of evaluation result using a small coil: Coil CXML321610-7R0)

6.8  $\mu\text{H}$  is optimum for illumination of serial LEDs 4 to 3 using  $I_F = 20 \text{ mA}$ .

4.7  $\mu\text{H}$  is recommended for steady illumination of serial LED 2 in the range  $V_{IN} > 4.5 \text{ V}$ .

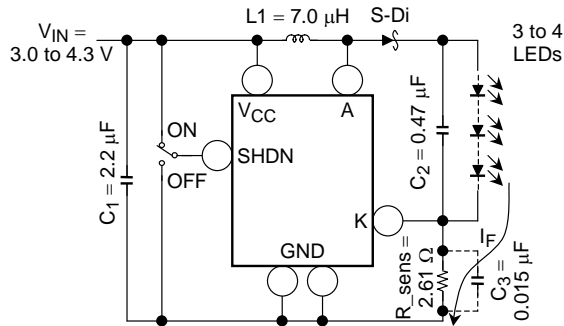

L1 : SUMITOMO CXML321610-7R0  
S-Di: TOSHIBA CUS02 30 V/1 A  
LED: NICHIA NSCW215T

Note 7: Connection of  $C_3$  is not necessary in every case. .  
The  $I_F$  is expected to stabilize on decrease of voltage. .

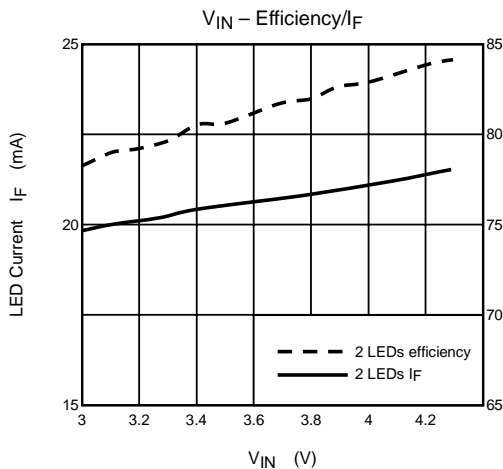
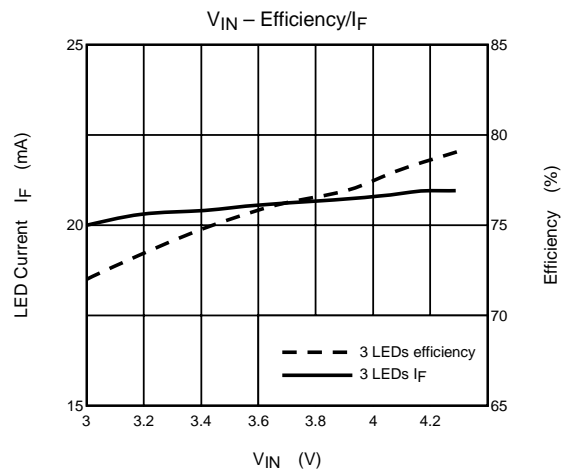
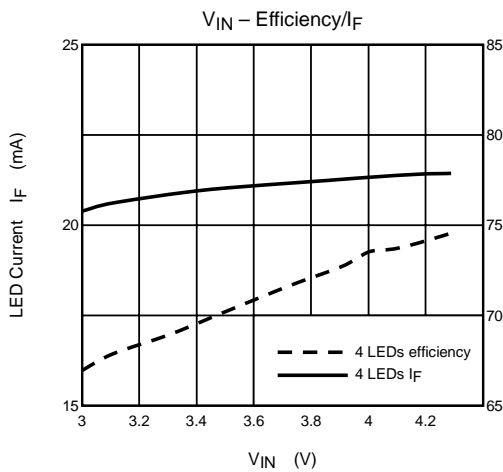

<Measurement>

Efficiency in the range  $V_{IN} = 3.0$  to  $4.3 \text{ V}$

Number of LED	Efficiency (%)	Average Efficiency (%)
2	78.2 to 84.1	81.3
3	72.0 to 79.1	75.8
4	66.9 to 71.1	74.6

$I_F$  in the range  $V_{IN} = 3.0$  to  $4.3 \text{ V}$

Number of LED	$I_F$ (mA)	$V_{CC}$ Dependence (%)
2	19.8 to 21.6	8.1
3	20.0 to 21.0	4.8
4	20.4 to 21.5	4.9

Note 8: The above values have been obtained through Toshiba's own measurements. However, results may vary according to the measurement environment.

## Application Evaluation Circuit Example 3 (Example of evaluation result using a small coil: Coil 976AS-6R8)

6.8  $\mu$ H is optimum for illumination of serial LEDs 4 to 3 using  $I_F = 20$  mA.

4.7  $\mu$ H is recommended for steady illumination of serial LED 2 in the range  $V_{IN} > 4.5$  V.

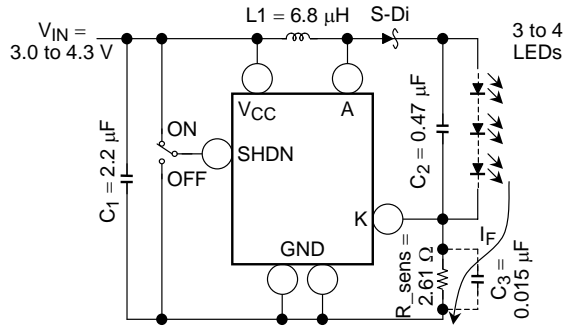

L1 : TOKO 976AS-6R8  
S-Di: TOSHIBA CUS02 30 V/1 A  
LED: NICHIA NSCW215T

Note 9: Connection of  $C_3$  is not necessary in every case. .  
The  $I_F$  is expected to stabilize on decrease of voltage. .

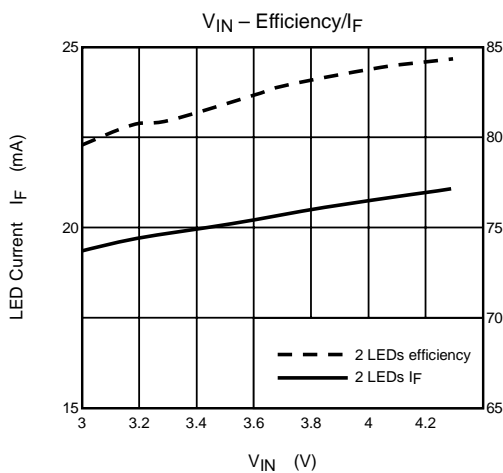
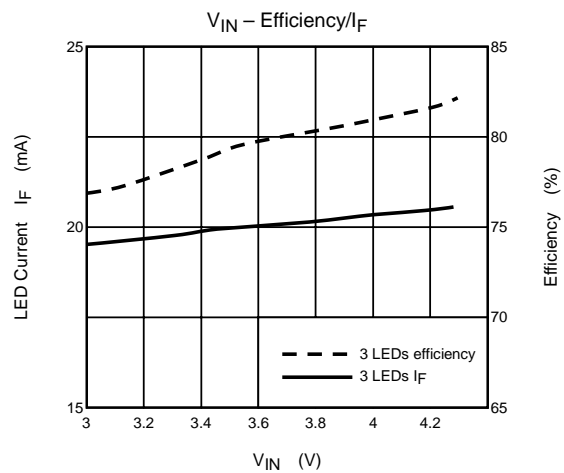
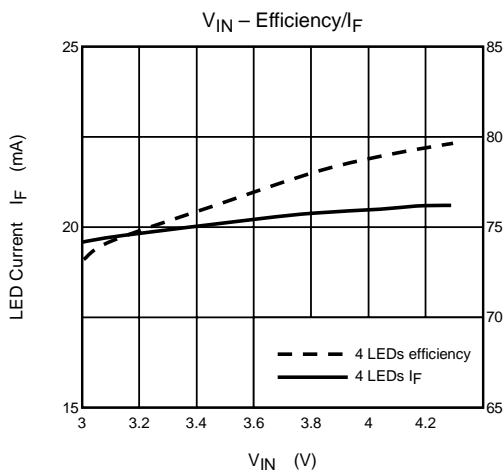

### <Measurement>

Efficiency in the range  $V_{IN} = 3.0$  to  $4.3$  V

Number of LED	Efficiency (%)	Average Efficiency (%)
2	79.7 to 84.4	82.3
3	76.7 to 82.1	79.5
4	73.1 to 79.7	74.0

$I_F$  in the range  $V_{IN} = 3.0$  to  $4.3$  V

Number of LED	$I_F$ (mA)	$V_{CC}$ Dependence (%)
2	19.4 to 21.1	8.1
3	19.5 to 20.5	5.1
4	19.6 to 20.7	5.3

Note 10: The above values have been obtained through Toshiba's own measurements. However, results may vary according to the measurement environment.

## Application Evaluation Circuit Example 4 (Example of evaluation result using a small coil: Coil CXLD140-6R8)

6.8  $\mu\text{H}$  is optimum for illumination of serial LEDs 4 to 3 using  $I_F = 20 \text{ mA}$ .

4.7  $\mu\text{H}$  is recommended for steady illumination of serial LED 2 in the range  $V_{IN} > 4.5 \text{ V}$ .

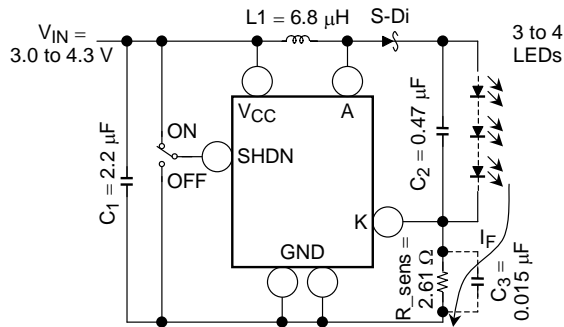

L1 : SUMITOMO CXLD140-6R8  
S-Di: TOSHIBA CUS02 30 A/1 V  
LED: NICHIA NSCW215T

Note11: Connection of  $C_3$  is not necessary in every case. .  
The  $I_F$  is expected to stabilize on decrease of voltage. .

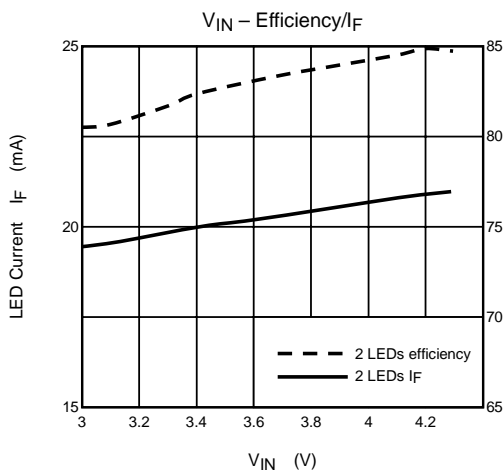
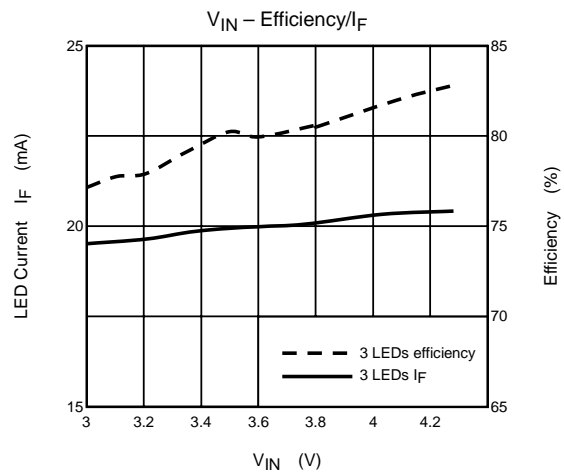
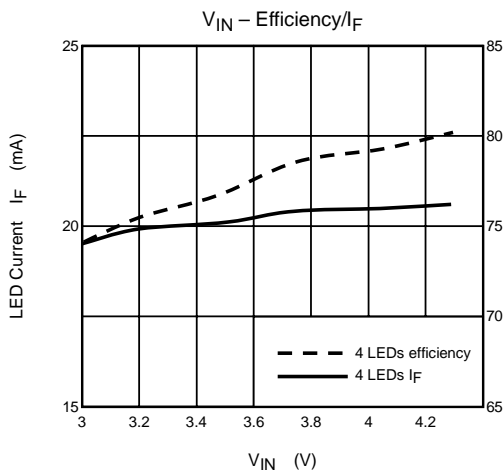

<Measurement>

Efficiency in the range  $V_{IN} = 3.0$  to  $4.3 \text{ V}$

Number of LED	Efficiency (%)	Average Efficiency (%)
2	80.3 to 84.9	82.9
3	77.2 to 82.8	80.2
4	74.1 to 80.4	77.6

$I_F$  in the range  $V_{IN} = 3.0$  to  $4.3 \text{ V}$

Number of LED	$I_F$ (mA)	$V_{CC}$ Dependence (%)
2	19.4 to 21.0	7.6
3	19.5 to 20.5	5.1
4	19.6 to 20.7	5.3

Note 12: The above values have been obtained through Toshiba's own measurements. However, results may vary according to the measurement environment.

## Package Dimensions

SSOP6-P-0.95B

Unit: mm

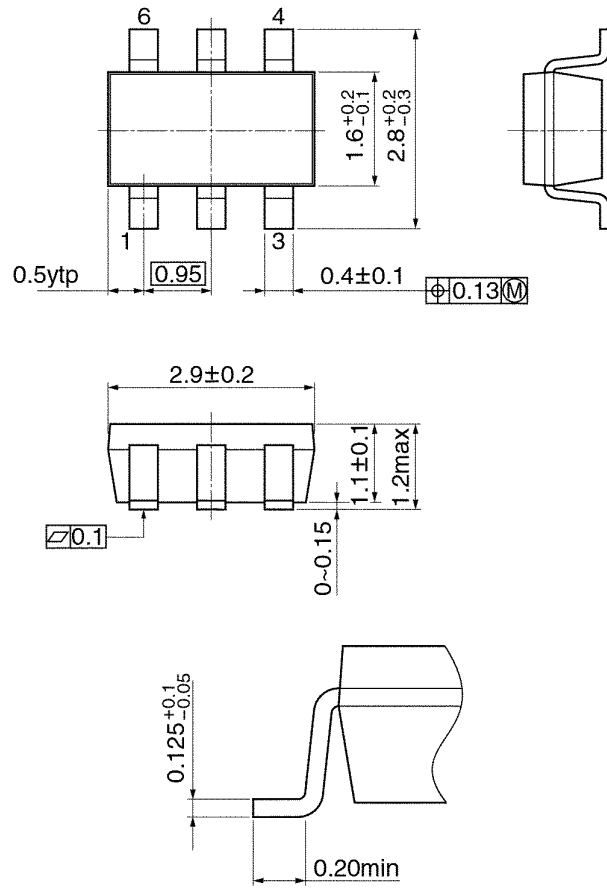

Weight: 0.016 g (typ.)

## Notes on Contents

### 1. Block Diagrams

Some of the functional blocks, circuits, or constants in the block diagram may be omitted or simplified for explanatory purposes.

### 2. Equivalent Circuits

The equivalent circuit diagrams may be simplified or some parts of them may be omitted for explanatory purposes.

### 3. Timing Charts

Timing charts may be simplified for explanatory purposes.

### 4. Application Circuits

The application circuits shown in this document are provided for reference purposes only.

Thorough evaluation is required, especially at the mass production design stage.

Toshiba does not grant any license to any industrial property rights by providing these examples of application circuits.

### 5. Test Circuits

Components in the test circuits are used only to obtain and confirm the device characteristics. These components and circuits are not guaranteed to prevent malfunction or failure from occurring in the application equipment.

## IC Usage Considerations

### Notes on Handling of ICs

- (1) The absolute maximum ratings of a semiconductor device are a set of ratings that must not be exceeded, even for a moment. Do not exceed any of these ratings.  
Exceeding the rating(s) may cause the device breakdown, damage or deterioration, and may result injury by explosion or combustion.
- (2) Use an appropriate power supply fuse to ensure that a large current does not continuously flow in case of over current and/or IC failure. The IC will fully break down when used under conditions that exceed its absolute maximum ratings, when the wiring is routed improperly or when an abnormal pulse noise occurs from the wiring or load, causing a large current to continuously flow and the breakdown can lead smoke or ignition. To minimize the effects of the flow of a large current in case of breakdown, appropriate settings, such as fuse capacity, fusing time and insertion circuit location, are required.
- (3) If your design includes an inductive load such as a motor coil, incorporate a protection circuit into the design to prevent device malfunction or breakdown caused by the current resulting from the inrush current at power ON or the negative current resulting from the back electromotive force at power OFF. IC breakdown may cause injury, smoke or ignition.  
Use a stable power supply with ICs with built-in protection functions. If the power supply is unstable, the protection function may not operate, causing IC breakdown. IC breakdown may cause injury, smoke or ignition.
- (4) Do not insert devices in the wrong orientation or incorrectly.  
Make sure that the positive and negative terminals of power supplies are connected properly. Otherwise, the current or power consumption may exceed the absolute maximum rating, and exceeding the rating(s) may cause the device breakdown, damage or deterioration, and may result injury by explosion or combustion.  
In addition, do not use any device that is applied the current with inserting in the wrong orientation or incorrectly even just one time.

- (5) Carefully select external components (such as inputs and negative feedback capacitors) and load components (such as speakers), for example, power amp and regulator.
- If there is a large amount of leakage current such as input or negative feedback condenser, the IC output DC voltage will increase. If this output voltage is connected to a speaker with low input withstand voltage, overcurrent or IC failure can cause smoke or ignition. (The over current can cause smoke or ignition from the IC itself.) In particular, please pay attention when using a Bridge Tied Load (BTL) connection type IC that inputs output DC voltage to a speaker directly.



**Points to Remember on Handling of ICs**

## (1) Heat Radiation Design

In using an IC with large current flow such as power amp, regulator or driver, please design the device so that heat is appropriately radiated, not to exceed the specified junction temperature ( $T_j$ ) at any time and condition. These ICs generate heat even during normal use. An inadequate IC heat radiation design can lead to decrease in IC life, deterioration of IC characteristics or IC breakdown. In addition, please design the device taking into consideration the effect of IC heat radiation with peripheral components.

## (2) Back-EMF

When a motor rotates in the reverse direction, stops or slows down abruptly, a current flow back to the motor's power supply due to the effect of back-EMF. If the current sink capability of the power supply is small, the device's motor power supply and output pins might be exposed to conditions beyond absolute maximum ratings. To avoid this problem, take the effect of back-EMF into consideration in system design.

About solderability, following conditions were confirmed

- Solderability
  - (1) Use of Sn-37Pb solder Bath
    - solder bath temperature = 230°C
    - dipping time = 5 seconds
    - the number of times = once
    - use of R-type flux
  - (2) Use of Sn-3.0Ag-0.5Cu solder Bath
    - solder bath temperature = 245°C
    - dipping time = 5 seconds
    - the number of times = once
    - use of R-type flux

## RESTRICTIONS ON PRODUCT USE

060116EBA

- The information contained herein is subject to change without notice. 021023\_D
- TOSHIBA is continually working to improve the quality and reliability of its products. Nevertheless, semiconductor devices in general can malfunction or fail due to their inherent electrical sensitivity and vulnerability to physical stress. It is the responsibility of the buyer, when utilizing TOSHIBA products, to comply with the standards of safety in making a safe design for the entire system, and to avoid situations in which a malfunction or failure of such TOSHIBA products could cause loss of human life, bodily injury or damage to property.  
In developing your designs, please ensure that TOSHIBA products are used within specified operating ranges as set forth in the most recent TOSHIBA products specifications. Also, please keep in mind the precautions and conditions set forth in the "Handling Guide for Semiconductor Devices," or "TOSHIBA Semiconductor Reliability Handbook" etc. 021023\_A
- The TOSHIBA products listed in this document are intended for usage in general electronics applications (computer, personal equipment, office equipment, measuring equipment, industrial robotics, domestic appliances, etc.). These TOSHIBA products are neither intended nor warranted for usage in equipment that requires extraordinarily high quality and/or reliability or a malfunction or failure of which may cause loss of human life or bodily injury ("Unintended Usage"). Unintended Usage include atomic energy control instruments, airplane or spaceship instruments, transportation instruments, traffic signal instruments, combustion control instruments, medical instruments, all types of safety devices, etc. Unintended Usage of TOSHIBA products listed in this document shall be made at the customer's own risk. 021023\_B
- The products described in this document shall not be used or embedded to any downstream products of which manufacture, use and/or sale are prohibited under any applicable laws and regulations. 060106\_Q
- The information contained herein is presented only as a guide for the applications of our products. No responsibility is assumed by TOSHIBA for any infringements of patents or other rights of the third parties which may result from its use. No license is granted by implication or otherwise under any patent or patent rights of TOSHIBA or others. 021023\_C
- The products described in this document are subject to the foreign exchange and foreign trade laws. 021023\_E