



LP Series - Digital is a surface mountable pressure sensor package with a compensated digital output suitable for ultra-low pressure sensing applications.

COMPANY: Merit Sensor is a leader in piezoresistive pressure sensing and partners with clients to create high performing solutions for a variety of applications and industries.

SENTIUM: Merit Sensor products incorporate a proprietary Sentium® technology developed to provide a best-in-class operating temperature range (-40°C to 85°C) and superior stability.

TECHNOLOGY: Merit Sensor utilizes a piezoresistive Wheatstone bridge in a design that anodically bonds glass to a chemically etched silicon diaphragm. All products are RoHS compliant.

CAPABILITIES: Merit Sensor designs, engineers, fabricates, dices, assembles, tests, and sells die and packaged products from a state-of-the-art facility near Salt Lake City, Utah.

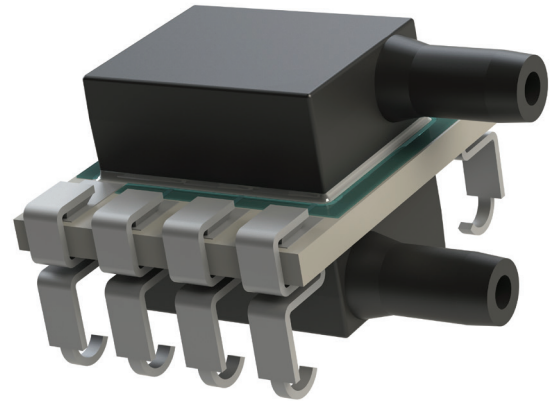

FEATURES

Pressure Range	0.15 to 1 psi (10.3 to 68.9 mbar; 1.03 to 6.89 KPa; 4.2 to 27.7 in H ₂ O)
Output	Digital I ² C
Type	Gage and Differential
Media	Clean, Dry Air and Non-corrosive Gases
Packaging	Tape and Reel
Customization	Supply Voltage, Temperature Calibration Range, Output Range, Accuracy Specification, Update Rate, etc

BENEFITS

Performance	Enjoy best-in-class performance due to Merit's proprietary Sentium technology
Cost	Save money over time with high-performing die
Security	Feel confident doing business with an experienced company backed by a solid parent company (NASDAQ: MMSI)
Speed	Get to market quickly with creative and flexible solutions
Service	Experience prompt, personal and professional support

1420 Family Part Number Configurator

1420-XXXX-XX11-111

Pressure P15 = .15psi P30 = .30psi 1P0 = 1.0psi	Reference D = Differential G = Gage	Clock Speed 1 = 1MHz	I²C Address 0 = 0x28 1 = 0x38 2 = 0x48 3 = 0x58 4 = 0x68 5 = 0x78 6 = Open*	Pin Type 1 = J-lead	Port 1 = Dual horizontal, facing same direction	Supply Voltage 1 = 5.0V	Update Rate 1 = 5ms	Operation Mode 1 = Update mode constant
---	--	--------------------------------	--	-------------------------------	---	-----------------------------------	-------------------------------	---

*Device will respond to any address.

SPECIFICATIONS

Parameter	Minimum	Typical	Maximum	Units	Notes
Electrical					
Supply Voltage (Vs)	2.7	5	5.5	V	
Supply Current	1.2	2	3.5	mA	(1)
Operating Temperature	-40		85	°C	
Storage Temperature	-55		100	°C	
Performance					
Effective ADC Resolution		13		Bits	
Pressure Accuracy	-1.5		1.5	%FS	(2) (3)
Long-Term Stability	-0.5		0.5	%FS	
Startup Time		15		ms	
Digital Update Time	2	5	125	ms	
Proof Pressure	5X				(4)
Burst Pressure	10 psi				
Transfer Function Formula					
$P_{psi} = (P_{max} - P_{min}) \cdot \left(\frac{P_{counts} - 0.1 \cdot Max}{0.8 \cdot Max} \right) + P_{min}$				Where P_{psi} = Measured Pressure in PSI P_{counts} = Pressure Counts from Merit Sensor Part P_{Min} = Minimum Pressure P_{Max} = Maximum Pressure Max = 16384 = 14 Bits	
Media Compatibility					
For Use With Non-corrosive Dry Gasses					
Solder temperature: max 250 °C, 5 seconds max					

Notes:
(1) @5V input voltage,
(2) Over 0°C to 60°C
(3) Applicable if Vdd = 4.75V to 5.25V
(4) Full scale pressure

CROSS SECTION

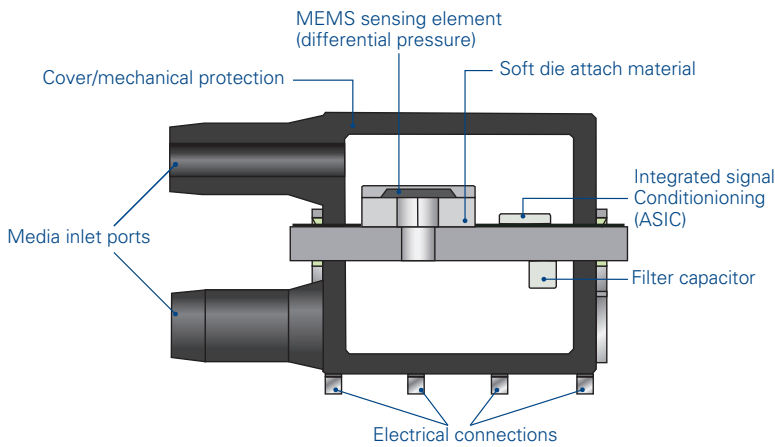

ELECTRICAL

Note: Power supply decoupling included

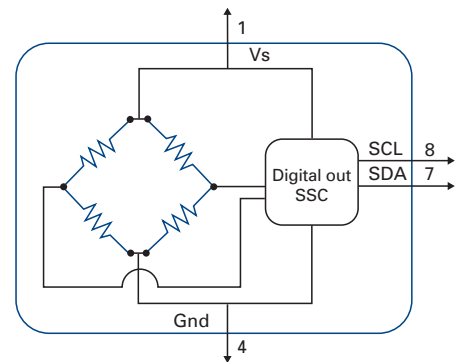

PACKAGING

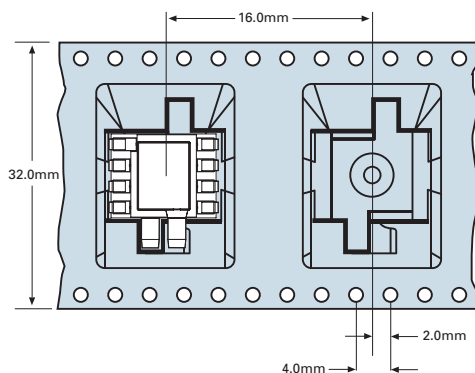

DIMENSIONS FOR STANDARD OPTIONS (in millimeters)

Dimensions for reference only. Engineering drawings (with tolerance) available upon order.

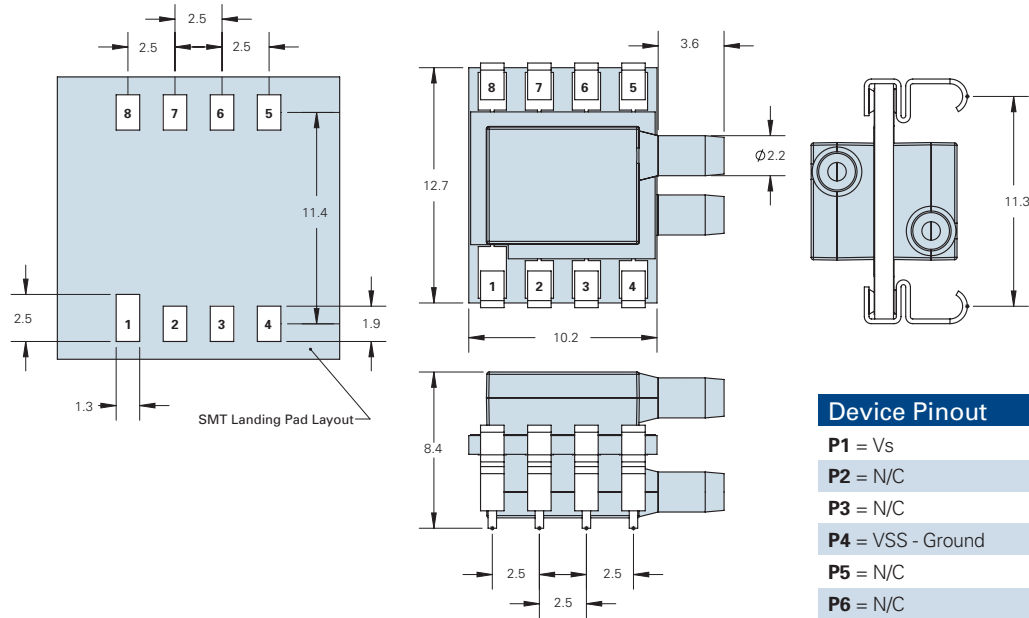

Device Pinout

- P1** = Vs
- P2** = N/C
- P3** = N/C
- P4** = VSS - Ground
- P5** = N/C
- P6** = N/C
- P7** = SDA - I²C data
- P8** = SCL - I²C clock

I²C PARAMETERS *

Parameter	Symbol	Min	Typ	Max	Units
SCL clock frequency	f _{SCL}	100		400	kHz
Start condition hold time relative to SCL edge	t _{HDSTA}	0.1			μs
Minimum SCL clock low width ¹	t _{LOW}	0.6			μs
Minimum SCL clock high width ¹	t _{HIGH}	0.6			μs
Start condition setup time relative to SCL edge	t _{SUSTA}	0.1			μs
Data hold time on SDA relative to SCL edge	t _{HDDAT}	0.0			μs
Data setup time on SDA relative to SCL edge	t _{SUDAT}	0.1			μs
Stop condition setup time on SCL	t _{SUSTO}	0.1			μs
Bus free time between stop condition and start condition	t _{BUS}	2			μs

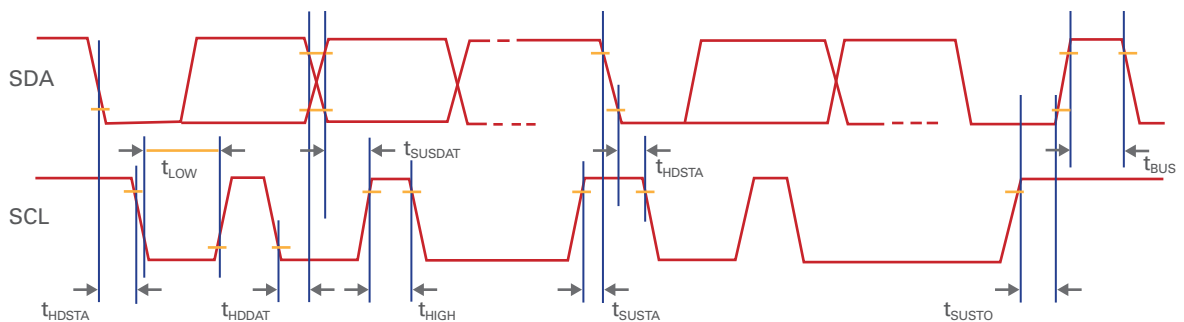
¹Combined low and high widths must equal or exceed minimum SCLK period.

I²C TIMING DIAGRAM*

MERIT SENSOR 1420 I²C COMMUNICATION

Communications to the 1420 is read only. To read the pressure counts, the master performs a read request by asserting a start condition, sending the 7 bit address of the part (If the part has an open address, 7 bits of anything is acceptable), and sets the read/write bit. The master then waits for an acknowledgment. The acknowledgment is sent by the pressure sensor along with 2 bits of status and bits 13:8 of the pressure counts, the master acknowledges the first 8 bits, and the pressure sensor sends the remaining 8 bits of data. The Master then does not acknowledge and sends a stop condition signaling the end of the transaction.

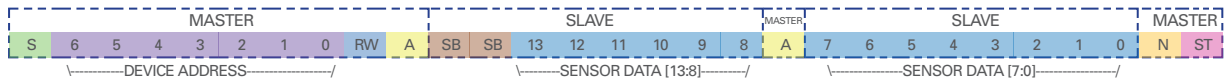

S Start Conditioning	# Device Slave Address	# Data Bit	Status Bits	
RW Read/Write Bit	A Acknowledge Bit	N No Acknowledge Bit	0 0	Normal Operation, Good Packet
ST Stop Condition	SB Status Bits		0 1	Device in Command Mode
			1 0	Stale Data
			1 1	Diagnostic Condition Exists

*Used by permission, IDT

TRANSFER FUNCTION EXAMPLES
Example 1: 0.15 PSI Gage

Part: 1420-P15G-xx11-111

$P_{min} = 0.0 \text{ PSI}$

$P_{max} = 0.15 \text{ PSI}$

$P_{counts} = 7215$

$Max = 16384$

$$P_{psi} = (P_{max} - P_{min}) \cdot \left(\frac{P_{counts} - 0.1 \cdot Max}{0.8 \cdot Max} \right) + P_{min}$$

$$P_{P_{psi}} = (0.15 - 0.0) \cdot \left(\frac{7215 - 0.1 \cdot 16384}{0.8 \cdot 16384} \right) + 0$$

$$P_{P_{psi}} = .0638 \text{ Psi}$$

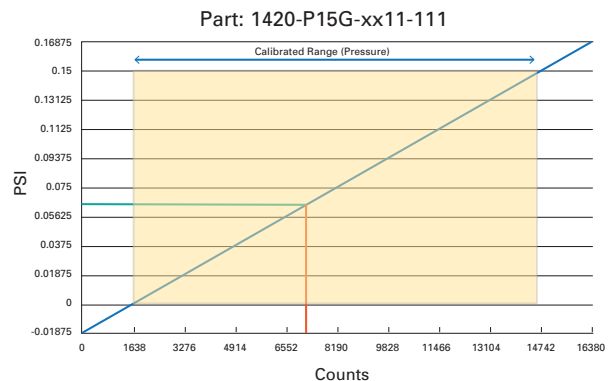
Example 2: -.5 to .5 PSI Differential

Part: 1420-P50D-xx11-111

$P_{min} = -0.5 \text{ PSI}$

$P_{max} = 0.5 \text{ PSI}$

$P_{counts} = 8192$

$Max = 16384$

$$P_{psi} = (P_{max} - P_{min}) \cdot \left(\frac{P_{counts} - 0.1 \cdot Max}{0.8 \cdot Max} \right) + P_{min}$$

$$P_{P_{psi}} = (0.5 - (-0.5)) \cdot \left(\frac{8192 - 0.1 \cdot 16384}{0.8 \cdot 16384} \right) + (-0.5)$$

$$P_{P_{psi}} = 0.0 \text{ Psi}$$

