

Aug.1.2022 Copyright 2022 HIROSE ELECTRIC CO., LTD. All Rights Reserved.
In case of consideration for using Automotive equipment / device which demand high reliability, kindly contact our sales window correspondents.

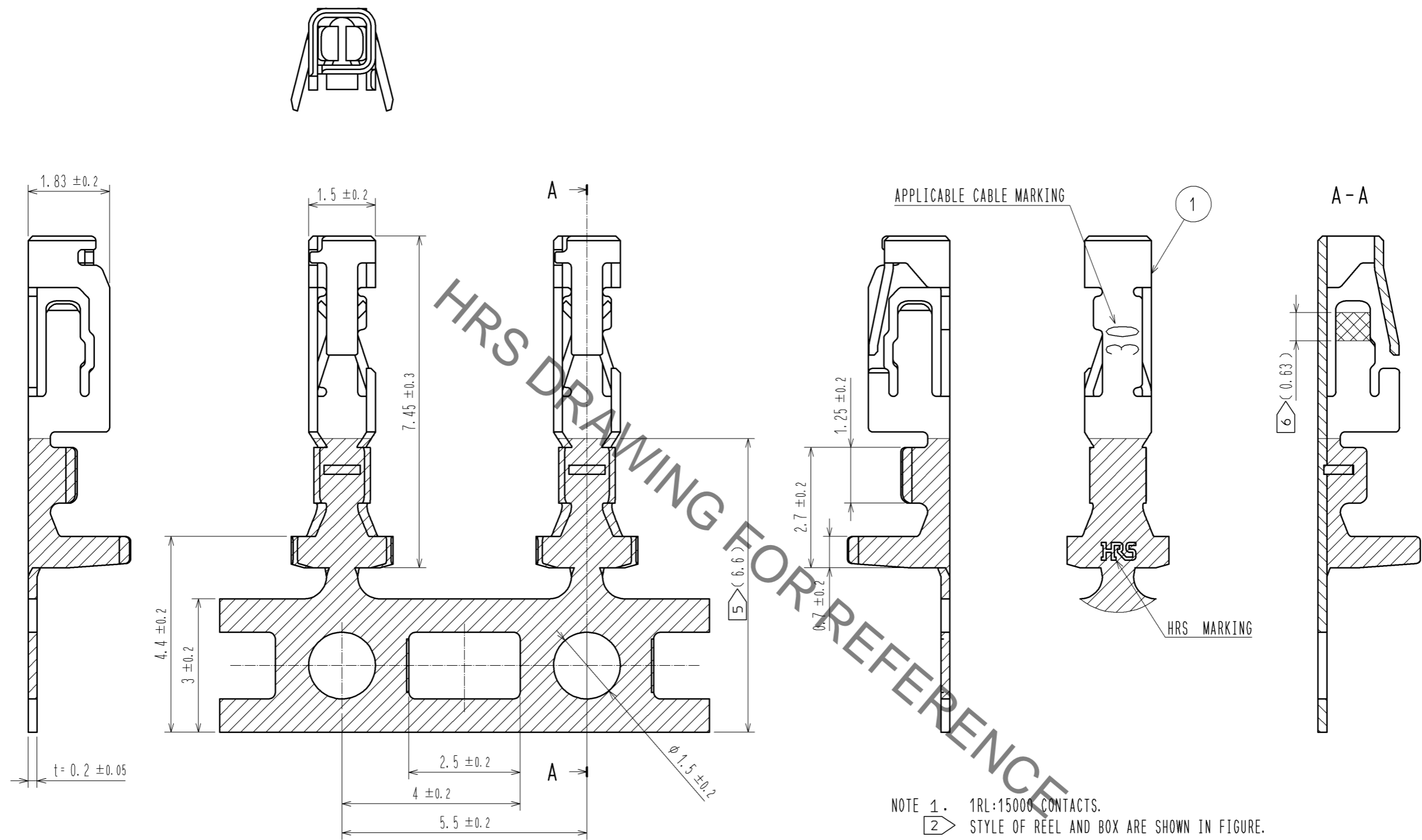

- NOTE 1. 1RL:15000 CONTACTS.
 2. STYLE OF REEL AND BOX ARE SHOWN IN FIGURE.
 3. A MAXIMUM OF 5 REELS ARE PACKED UP IN ONE BOX.
 4. PLEASE BE SURE TO CHECK THE FORM OF CRIMPING USING A CABLE. WHEN YOU ADJUST APPLICATOR.
 5. TIN PLATING AREA.
 6. GOLD PLATING AREA.
 7. THE DIMENSIONS IN PARENTHESIS ARE FOR REFERENCE.

2. STYLE AND DIMENSION OF REEL

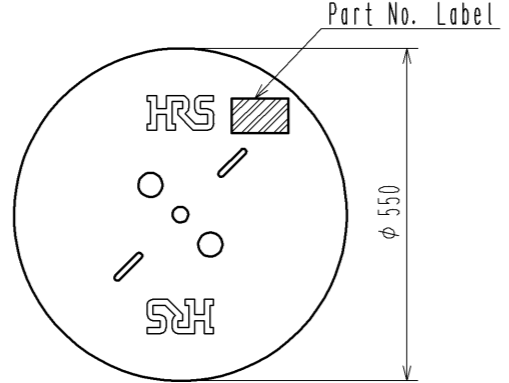

Detail of part No. Label

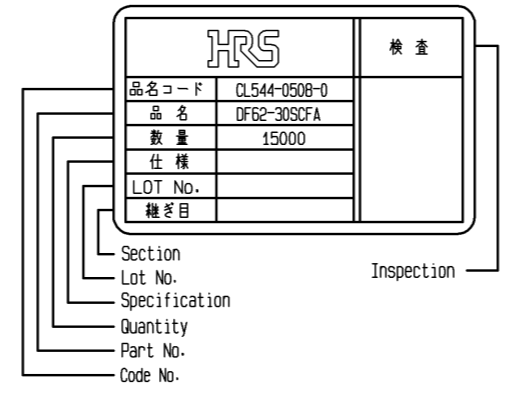

NO.		MATERIAL	FINISH . REMARKS	NO.	MATERIAL	FINISH . REMARKS			
UNITS mm		①	SCALE 10 : 1	△	COUNT	DESCRIPTION OF REVISIONS	DESIGNED	CHECKED	DATE
HRS		HIROSE ELECTRIC CO., LTD.	APPROVED : KI. AKIYAMA	12.01.20	DRAWING NO. EDC3-339878-00				
			CHECED : MN. KENJO	12.01.20	PART NO. DF62-30SCFA				
			DESIGNED : TO. HORII	12.01.20	CODE NO. CL544-0508-0-00				
			DRAWN : TO. HORII	12.01.20			1/1		