

- **Designed for SDARS IF Receiver**
- **Low Insertion Loss**
- **5.0 X 7.0 mm Surface-Mount Case**
- **Differential Input and Output**
- **Complies with Directive 2002/95/EC (RoHS)**
- **Moisture Sensitivity Level: 1**
- **AEC-Q200 Qualified**

RoHS
Compliant

SF1141B-4

75.00 MHz
SAW Filter

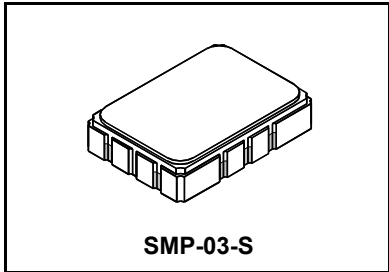

Absolute Maximum Ratings

Rating	Value	Units
Maximum Incident Power in Passband	+10	dBm
Max. DC voltage between any 2 terminals	30	VDC
Storage Temperature Range	-40 to +85	°C
Max Soldering Profile	265°C for 10 s	

Electrical Characteristics

Characteristic	Sym	Notes	Min	Typ	Max	Units
Nominal Center Frequency	f_C			75.000		MHz
Passband	Insertion Loss at f_C	IL		12.5	16.0	dB
		1dB Passband	BW_1	±6.35	±7.43	
	Fast Amplitude Ripple over $f_C \pm 6.35$ MHz				1.5	dB _{P-P}
	Group Delay Variation over $f_C \pm 6.35$ MHz	GDV		75	200	ns _{P-P}
Rejection	$f_C - 100$ to $f_C - 18.8$ MHz		40	45		dB
		$f_C - 18.8$ to $f_C - 10.95$ MHz	37	45		
		$f_C + 10.95$ to $f_C + 18.8$ MHz	30	36		
		$f_C + 18.8$ to $f_C + 100$ MHz	40	45		
Operating Temperature Range	T_A		-40		+85	°C
Differential Input and Output Impedance	250 ohms					
Case Style	SMP-03-S 7 x 5 mm Nominal Footprint					
Lid Symbolization (YY=year, WW=week, S=shift)	RFM , SF1141B-4, <u>YYWWS</u>					

Electrical Connections

Connection	Port 1 Hot	Port 1 Ground Return or Hot	Port 2 Hot	Port 2 Ground Return or Hot	Case Ground
Terminals	10	1	5	6	All Others

CAUTION: Electrostatic Sensitive Device. Observe precautions for handling.
NOTES:

1. The design, manufacturing process, and specifications of this device are subject to change.
2. US or International patents may apply.
3. RoHS compliant from the first date of manufacture.

Tape and Reel Specifications

Tape and Reel Standard per ANSI/EIA-481

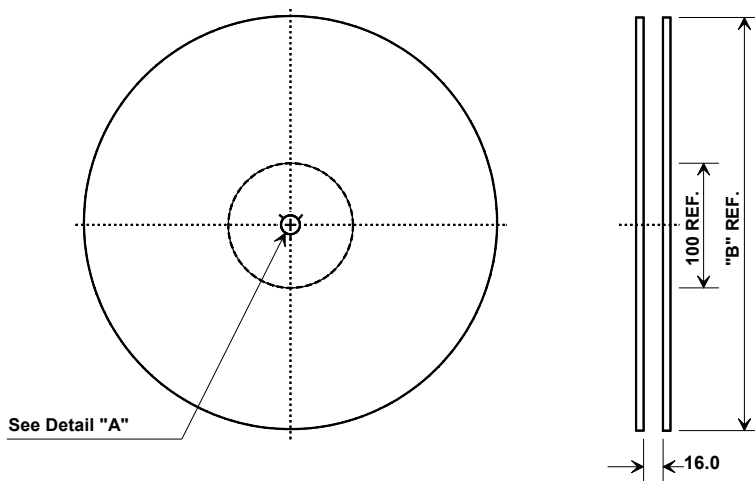

"B" Nominal Size		Quantity Per Reel
Inches	millimeters	
7	178	500
13	330	2000

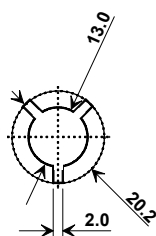

COMPONENT ORIENTATION and DIMENSIONS

Carrier Tape Dimensions		Tolerance
Ao	5.5 mm	± 0.1mm
Bo	7.5 mm	± 0.1mm
Ko	2.0 mm	± 0.1mm
Pitch	8.0 mm	± 0.1mm
W	16.0 mm	± 0.2mm

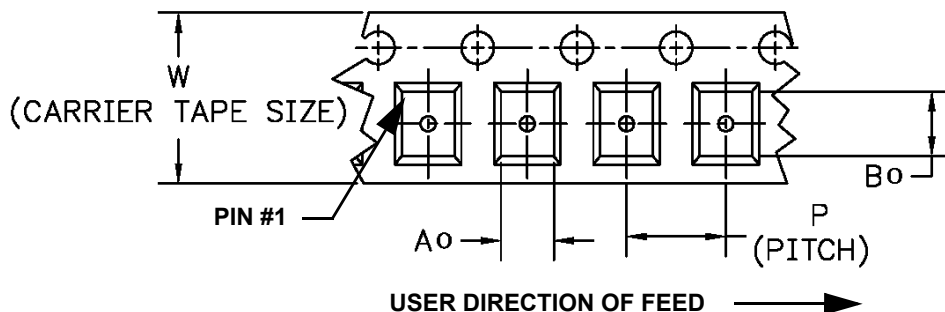
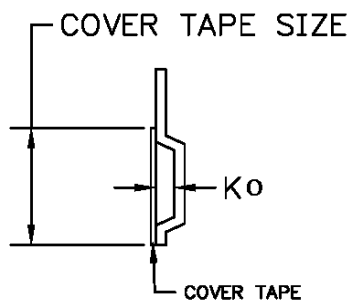

SMP-03-S Case

12-Terminal Ceramic Surface-Mount Case

5 x 7 mm Nominal Footprint

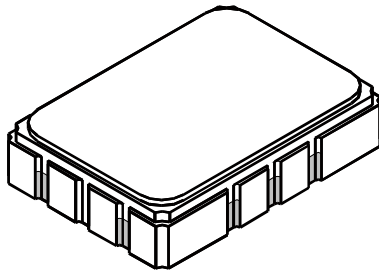

Case Dimensions						
Dimension	mm			Inches		
	Min	Nom	Max	Min	Nom	Max
A	6.80	7.00	7.20	0.268	0.276	0.283
B	4.80	5.00	5.20	0.189	0.197	0.205
C		1.65	2.00		0.065	0.079
D		0.80				
E	2.41	2.54	2.67	0.095	0.100	0.105
H	0.87	1.1	1.13	0.034	0.039	0.044
J		2.54				
K	2.87	3.00	3.13	0.113	0.118	0.123
P	1.14	1.27	1.40	0.045	0.050	0.055

Materials	
Solder Pad Termination	Au plating 30 - 60 μinches (76.2-152 μm) over 80-200 μinches (203-508 μm) Ni.
Lid	Fe-Ni-Co Alloy Electroless Nickel Plate (8-11% Phosphorus) 100-200 μinches Thick
Body	Al ₂ O ₃ Ceramic

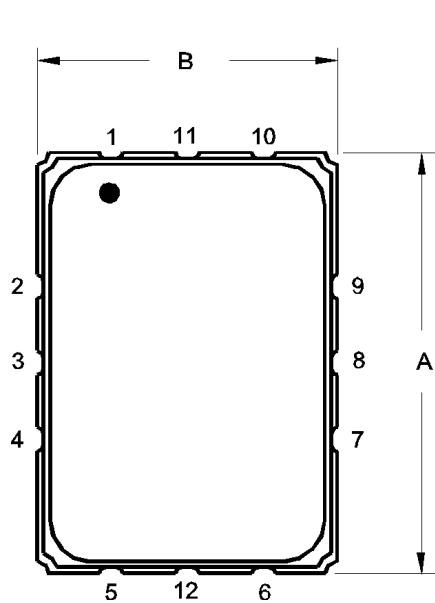

TOP VIEW

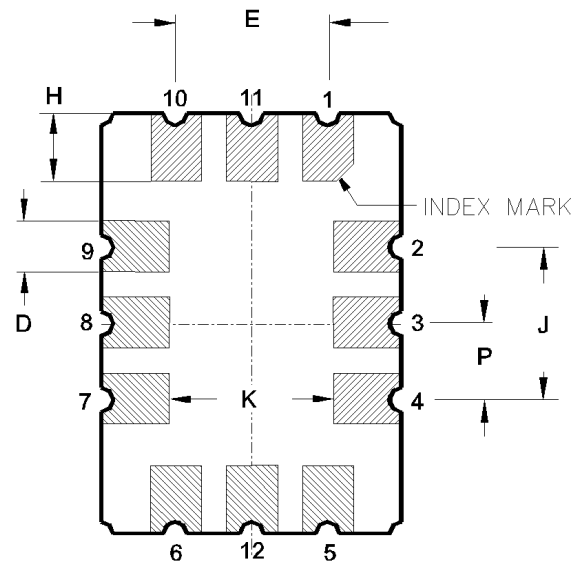
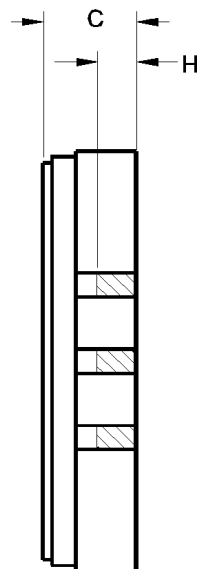

BOTTOM VIEW

Recommended Reflow Profile

1. Preheating shall be fixed at 150~180°C for 60~90 seconds.
2. Ascending time to preheating temperature 150°C shall be 30 seconds min.
3. Heating shall be fixed at 220°C for 50~80 seconds and at 260°C+0/-5°C peak (10 seconds).
4. Time: 5 times maximum.

