

2SC3647U

NPN Silicon Epitaxial Planar Transistor

for power amplification applications

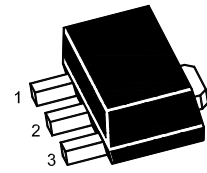

1.Base 2.Collector 3.Emitter
SOT-89 Plastic Package

Absolute Maximum Ratings ($T_a = 25^\circ\text{C}$)

Parameter	Symbol	Value	Unit
Collector Base Voltage	V_{CBO}	120	V
Collector Emitter Voltage	V_{CEO}	100	V
Emitter Base Voltage	V_{EBO}	6	V
Collector Current	I_C	2	A
Peak Collector Current	I_{CM}	3	A
Collector Power Dissipation	P_C	0.5 ¹⁾ 1.5 ²⁾	W
Junction Temperature	T_j	150	$^\circ\text{C}$
Storage Temperature Range	T_{stg}	- 55 to + 150	$^\circ\text{C}$

Thermal Resistance Ratings

Parameter	Symbol	Max.	Unit
Maximum Junction to Ambient	$R_{\theta JA}$	250 ¹⁾ 83 ²⁾	$^\circ\text{C/W}$

¹⁾ Device mounted on FR-4 substrate PC board, with minimum recommended pad layout.

²⁾ Device mounted on FR-4 substrate PC board, 2oz copper, with 1-inch square copper plate

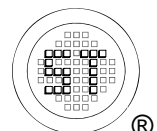

2SC3647U

Characteristics at $T_a = 25^\circ\text{C}$

Parameter	Symbol	Min.	Typ.	Max.	Unit	
DC Current Gain at $V_{CE} = 5\text{ V}$, $I_C = 100\text{ mA}$	R	h_{FE}	100	-	200	-
	S	h_{FE}	140	-	280	-
	T	h_{FE}	200	-	400	-
Collector Base Cutoff Current at $V_{CB} = 100\text{ V}$	I_{CBO}	-	-	100	nA	
Emitter Base Cutoff Current at $V_{EB} = 4\text{ V}$	I_{EBO}	-	-	100	nA	
Collector Base Breakdown Voltage at $I_C = 10\text{ }\mu\text{A}$	$V_{(BR)CBO}$	120	-	-	V	
Collector Emitter Breakdown Voltage at $I_C = 1\text{ mA}$	$V_{(BR)CEO}$	100	-	-	V	
Emitter Base Breakdown Voltage at $I_E = 10\text{ }\mu\text{A}$	$V_{(BR)EBO}$	6	-	-	V	
Collector Emitter Saturation Voltage at $I_C = 1\text{ A}$, $I_B = 100\text{ mA}$	$V_{CE(sat)}$	-	-	0.4	V	
Base Emitter Saturation Voltage at $I_C = 1\text{ A}$, $I_B = 100\text{ mA}$	$V_{BE(sat)}$	-	-	1.2	V	
Transition Frequency at $V_{CE} = 10\text{ V}$, $I_C = 100\text{ mA}$	f_T	-	120	-	MHz	
Collector Output Capacitance at $V_{CB} = 10\text{ V}$, $f = 1\text{ MHz}$	C_{ob}	-	16	-	pF	
Turn-on Time at $V_{CC} = 50\text{ V}$, $I_C = 10I_{B1} = -10I_{B2} = 0.7\text{ A}$	t_{on}	-	80	-	ns	
Storage Time at $V_{CC} = 50\text{ V}$, $I_C = 10I_{B1} = -10I_{B2} = 0.7\text{ A}$	t_{stg}	-	1000	-	ns	
Fall Time at $V_{CC} = 50\text{ V}$, $I_C = 10I_{B1} = -10I_{B2} = 0.7\text{ A}$	t_f	-	50	-	ns	

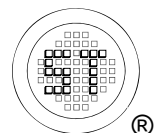

2SC3647U

Electrical Characteristics Curves

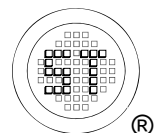
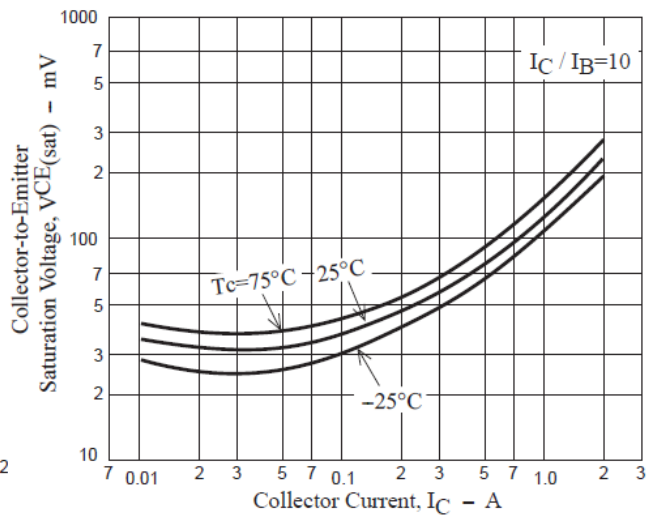
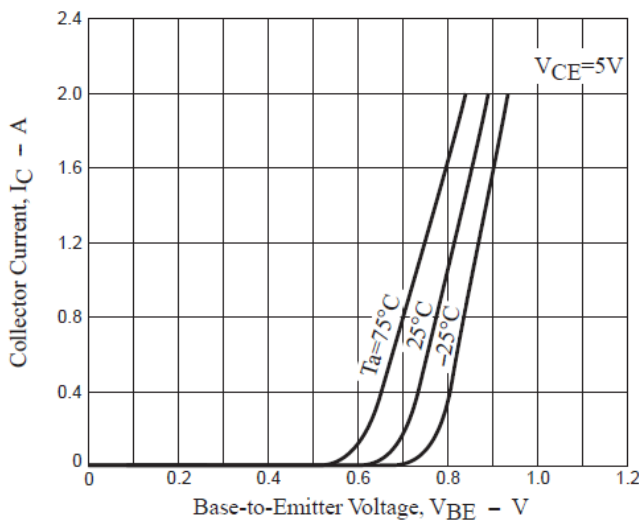
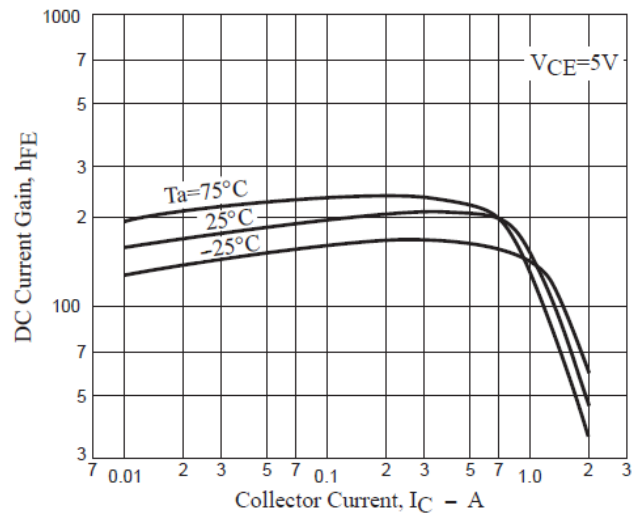
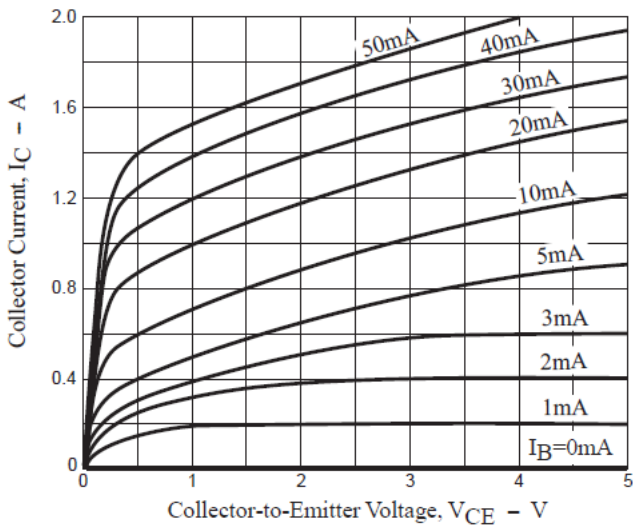

2SC3647U

Package Outline (Dimensions in mm)

SOT-89

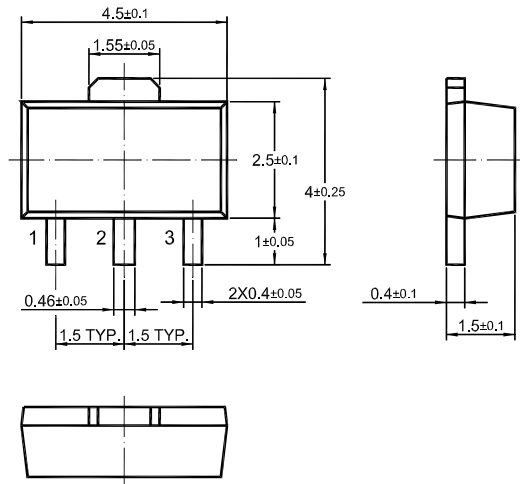

Recommended Soldering Footprint

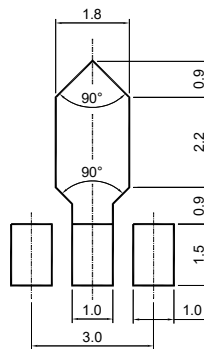

Packing information

Package	Tape Width (mm)	Pitch		Reel Size		Per Reel Packing Quantity
		mm	inch	mm	inch	
SOT-89	12	8 ± 0.1	0.315 ± 0.004	178	7	1,000
				330	13	4,000

Marking information

" 2SC3647*U " = Part No. (" * " Current Gain Code)

"YM" = Date Code Marking

"Y" = Year

"M" = Month

Font type: Arial

