

Jul.1.2022 Copyright 2022 HIROSE ELECTRIC CO., LTD. All Rights Reserved.
 In case of consideration for using Automotive equipment / device which demand high reliability, kindly contact our sales window correspondents.

CABLE ASSEMBLY TOOL

FOR SOLDERING : HRM-200/SO-MD

FOR PRESS FITTING : HRM-200-PJ4BN/CV-MD

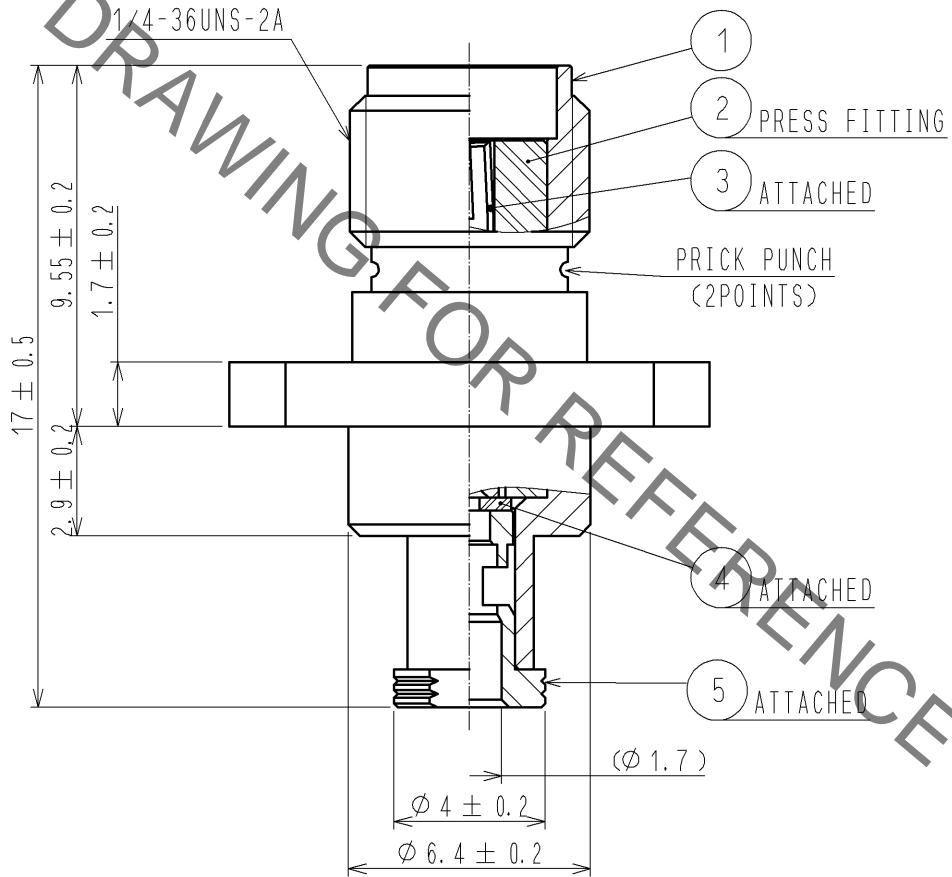
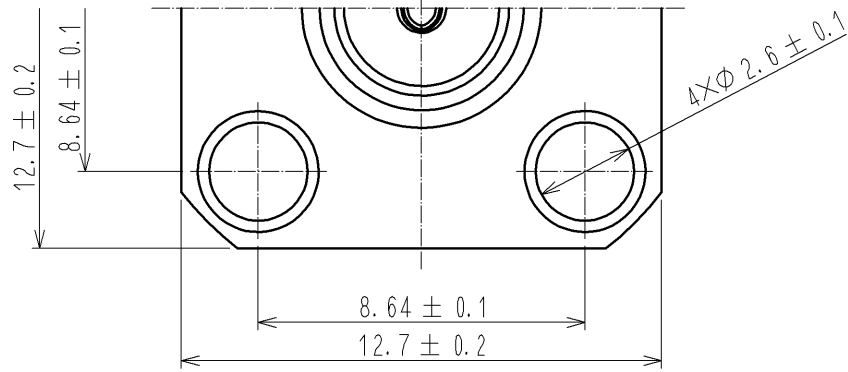

RoHS COMPLIANT

3	BERYLLIUM COPPER	GOLD PLATING					
2	PTFE		5	BRASS	GOLD PLATING		
1	BRASS	NICKEL PLATING	4	PTFE			
NO.	MATERIAL	FINISH .	REMARKS	NO.	MATERIAL	FINISH .	REMARKS

UNITS mm		SCALE 5 : 1	COUNT 	DESCRIPTION OF REVISIONS	DESIGNED	CHECKED	DATE
-------------	--	----------------	-----------	--------------------------	----------	---------	------

HIROSE ELECTRIC CO., LTD.	APPROVED : TS. NOBE	11. 09. 24	DRAWING NO.	EDC4-305375-40
	CHECKED : NK. NINOMIYA	11. 09. 24	PART NO.	HRM-200-088PJ4BN<40>
	DESIGNED : YI. FUNADA	11. 09. 24	CODE NO.	CL323-0803-3-40
	DRAWN : YI. FUNADA	11. 09. 24		