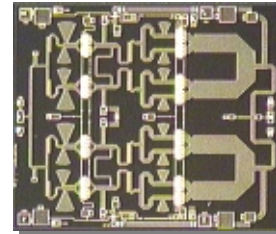

**Description**

The Raytheon RMPA25000 is a high efficiency power amplifier designed for use in Sat-Com, point to point radio, point to multi-point communications, LMDS and other millimeter wave applications. The RMPA25000 is a 2-stage GaAs MMIC amplifier utilizing Raytheon's advanced 0.15 mm gate length Power PHEMT process and can be used in conjunction with other driver or power amplifiers to achieve the required total power output.

**Features**

- ◆ 18 dB small signal gain (typ.)
- ◆ 33 dBm saturated power out (typ.)
- ◆ Circuit contains individual source vias
- ◆ Chip size 4.45 mm x 3.87 mm

**Absolute Maximum Ratings**

Parameter	Symbol	Value	Unit
Positive DC Voltage (+5 V Typical)	Vd	+ 6	Volts
Negative DC Voltage	Vg	- 2	Volts
Simultaneous (Vd - Vg)	Vdg	+ 8	Volts
Positive DC Current	Id	2096	mA
RF Input Power (from 50 Ω source)	Pin	+20	dBm
Operating Base plate Temperature	Tc	-30 to +85	°C
Storage Temperature Range	Tstg	-55 to +125	°C
Thermal Resistance (Channel to Backside)	Rjc	8.8	°C/W

**Electrical Characteristics<sup>1</sup>**

Parameter	Min	Typ	Max	Unit
Frequency Range	23.5		26	GHz
Gate Voltage (Vg) <sup>2</sup>		-0.3		V
Gain Small Signal (Pin=-5 dBm)	13	18		dB
Gain Variation vs. Frequency		+/-1		dB
Power Output at 1 dB Compression		32		dBm
Power Output Saturated: (Pin=+17 dBm)	31.5	33		dBm

Parameter	Min	Typ	Max	Unit
Drain Current at Pin=-5 dBm		1200		mA
Drain Current at P1 dB Compression		1430		mA
Power Added Efficiency (PAE) at P1dB		22		%
OIP3		38		dBm
Input Return Loss (Pin=-5 dBm)		12		dB
Output Return Loss (Pin=-5 dBm)		12		dB

**Note:**

1. Operated at 25°C, 50 ohm system, Vd=+5V, quiescent current (Idq)=1200 mA).
2. Typical range of the negative gate voltage is -1.0 to 0.0V to set typical Idq of 1200 mA.

**Characteristic performance data and specifications are subject to change without notice.**

# RMPA25000

## 23.5-26 GHz 2 Watt Power Amplifier MMIC

ADVANCED INFORMATION

**Application Information**

**CAUTION: THIS IS AN ESD SENSITIVE DEVICE**

Chip carrier material should be selected to have GaAs compatible thermal coefficient of expansion and high thermal conductivity such as copper molybdenum or copper tungsten. The chip carrier should be machined, finished flat, plated with gold over nickel and should be capable of withstanding 325°C for 15 minutes.

Die attachment for power devices should utilize Gold/Tin (80/20) eutectic alloy solder and should avoid hydrogen environment for PHEMT devices. Note that the backside of the chip is gold plated and is used as RF and DC Ground.

These GaAs devices should be handled with care and stored in dry nitrogen environment to prevent contamination of bonding surfaces. These are ESD sensitive devices and should be handled with appropriate precaution including the use of wrist-grounding straps. All die attach and wire/ribbon bond equipment must be well grounded to prevent static discharges through the device.

Recommended wire bonding uses 3 mils wide and 0.5 mil thick gold ribbon with lengths as short as practical allowing for appropriate stress relief. The RF input and output bonds should be typically 0.012" long corresponding to a typical 2 mil gap between the chip and the substrate material.

**Figure 1**  
Functional Block Diagram

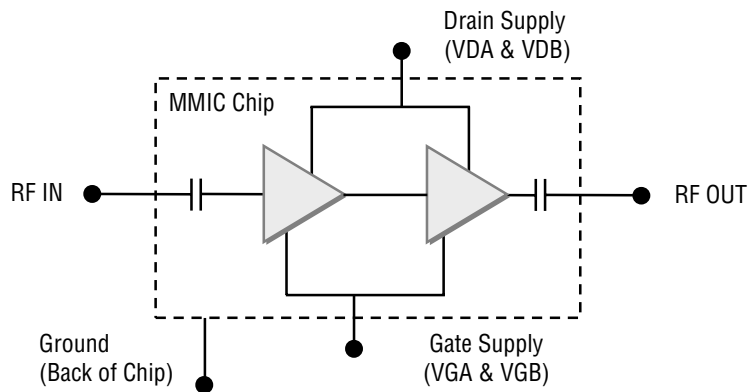

**Figure 2**  
Chip Layout and Bond Pad Locations

(Chip Size=4.454 mm x 3.874 mm x 50 μm.  
Back of Chip is RF and DC Ground)

Dimensions in mm

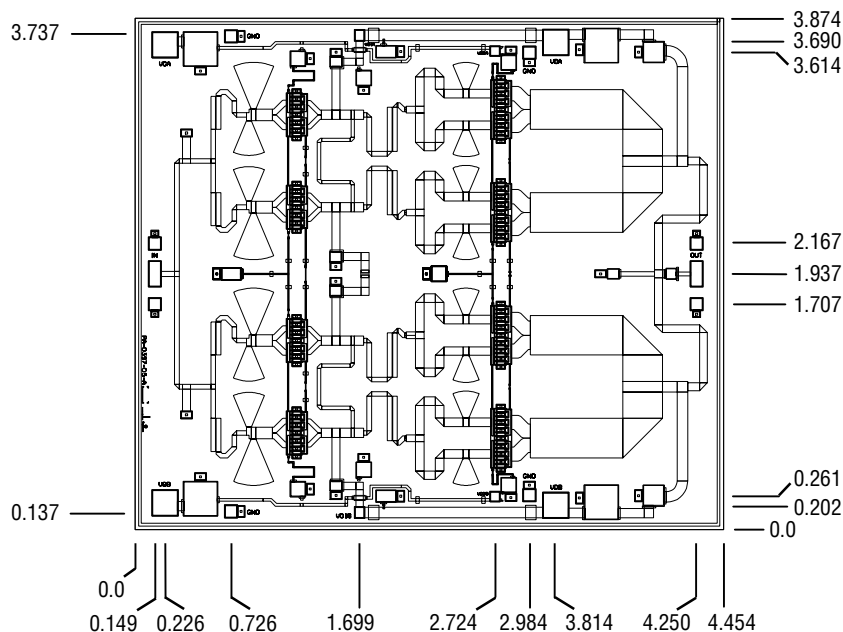

Characteristic performance data and specifications are subject to change without notice.

# RMPA25000

## 23.5-26 GHz 2 Watt Power Amplifier MMIC

ADVANCED INFORMATION

**Figure 3**  
Schematic of  
Application Circuit

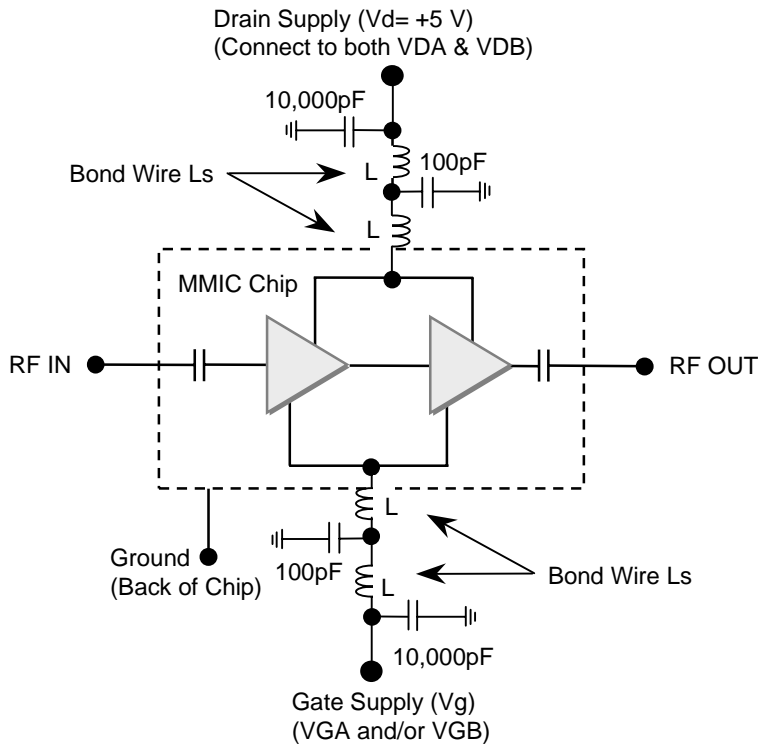

**Figure 4**  
Recommended  
Assembly and  
Bonding Diagram

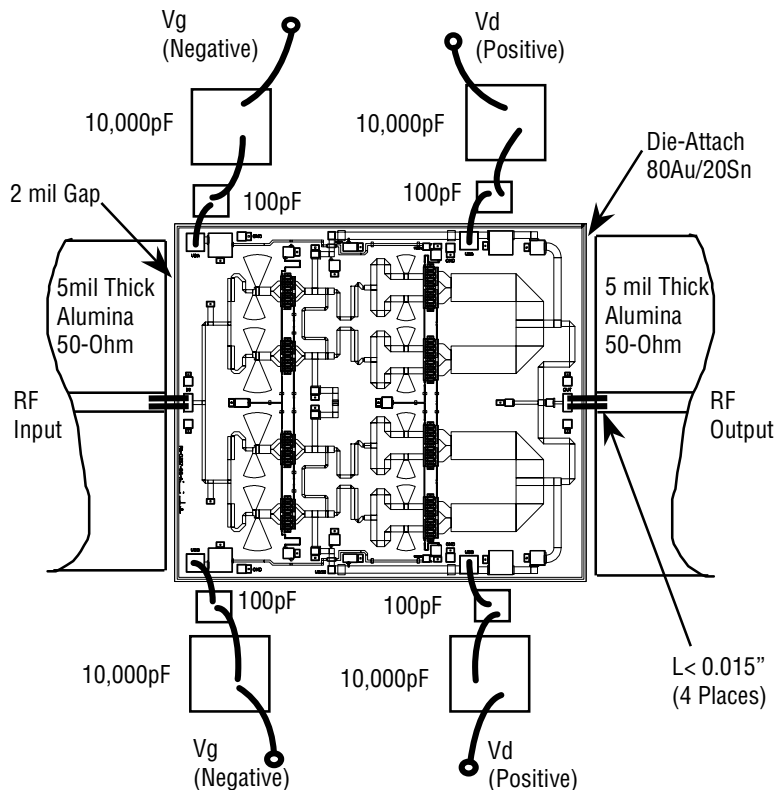

**Note:** Use 0.003" x 0.0005" Gold Ribbon for bonding. RF input and output bonds should be less than 0.015" long with stress relief.

**Characteristic performance data and specifications are subject to change without notice.**

# RMPA25000

## 23.5-26 GHz 2 Watt Power Amplifier MMIC

ADVANCED INFORMATION

**Recommended Procedure**  
for biasing and operation

**CAUTION: LOSS OF GATE VOLTAGE ( $V_g$ ) WHILE CORRESPONDING DRAIN VOLTAGE ( $V_d$ ) IS PRESENT CAN DAMAGE THE AMPLIFIER.**

The following sequence must be followed to properly test the amplifier.

- Step 1:** Turn off RF input power.
- Step 2:** Connect the DC supply grounds to the ground of the chip carrier.  
Slowly apply negative gate bias supply voltage of -1.5 V to  $V_g$ .
- Step 3:** Slowly apply positive drain bias supply voltage of +5 V to  $V_d$ .
- Step 4:** Adjust gate bias voltage to set the quiescent current of  $I_{dq}=1200$  mA
- Step 5:** After the bias condition is established, the RF input signal may now be applied at the appropriate frequency band.
- Step 6:** Follow turn-off sequence of:
  - (i) Turn off RF Input Power
  - (ii) Turn down and off drain voltage ( $V_d$ ).
  - (iii) Turn down and off gate bias voltage( $V_g$ ).

**Performance Data**

**RMPA25000 S11, S21, S22 Mag Vs. Frequency**  
Bias  $V_d=5V$   $I_{dq}=1200$  mA,  $T=25^\circ C$

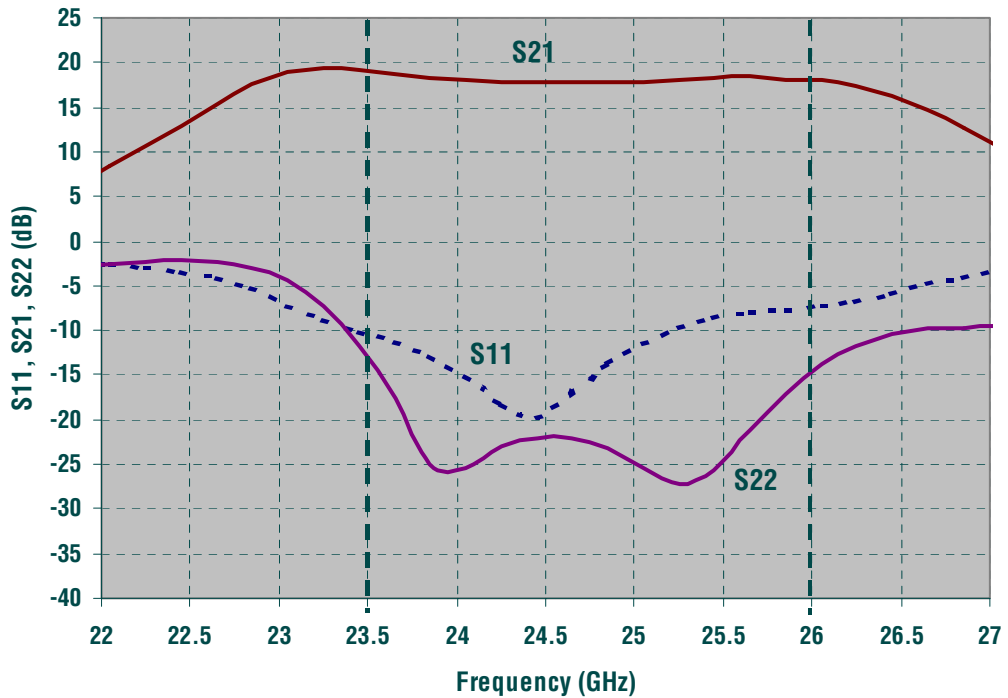

Characteristic performance data and specifications are subject to change without notice.

# RMPA25000

## 23.5-26 GHz 2 Watt Power Amplifier MMIC

ADVANCED INFORMATION

Performance Data

RMPA25000 Gain Vs. Pout  
Bias Vd=5V Idq=1200mA T=25°C

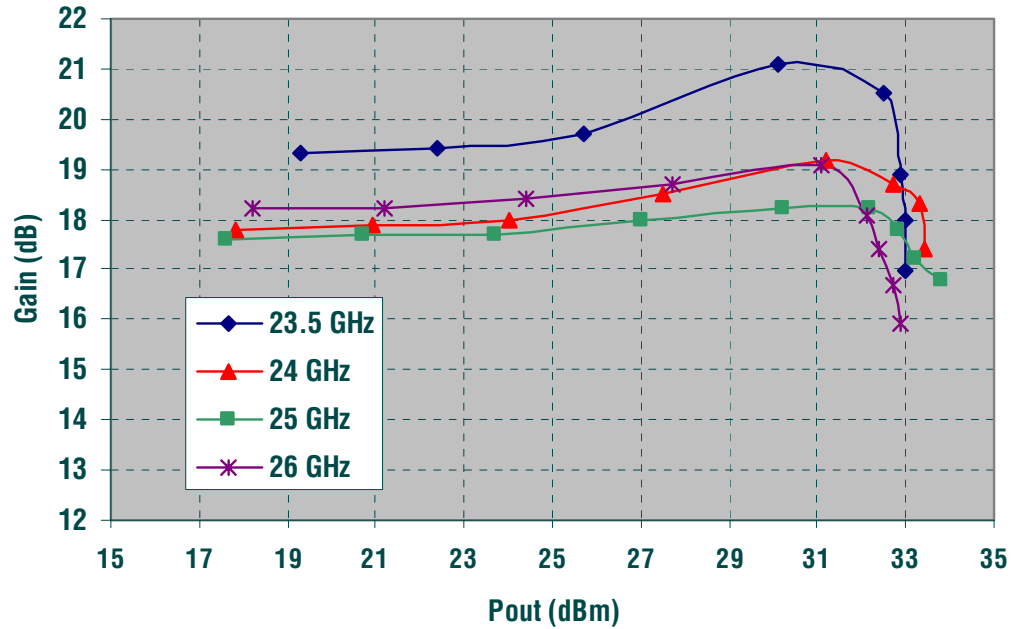

RMPA25000 SS Gain, Psat Vs. Frequency  
Bias Vd=5V Idq=1200mA T=25°C

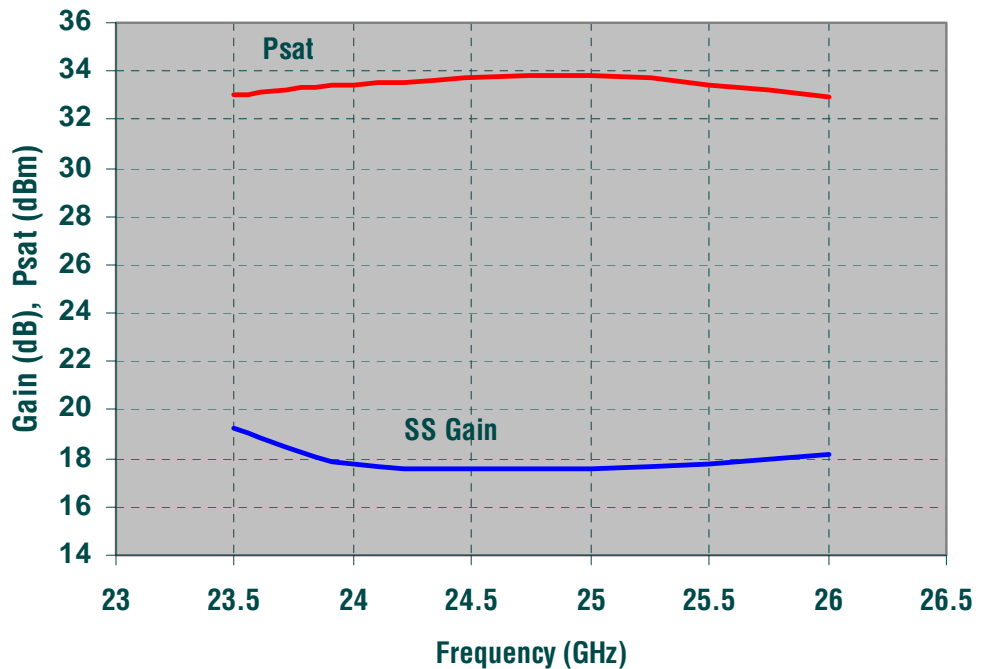

Characteristic performance data and specifications are subject to change without notice.

This datasheet has been downloaded from:

[www.DatasheetCatalog.com](http://www.DatasheetCatalog.com)

Datasheets for electronic components.