



DESCRIPTION:

T06xxH series triacs of high junction temperature with high dv/dt rate with strong resistance to electromagnetic interference provide high ability to withstand the shock loading of large current. They are especially recommended for use on inductive load and high environment temperature condition.

From all three terminals to external heatsink, T06xxH-xxA provides a rated insulation voltage of 2500 V_{RMS}, and T06xxH-xxF provides a rated insulation voltage of 2000 V_{RMS}, complying with UL standards (File ref: E252906).

MAIN FEATURES

Symbol	Value	Unit
$I_{T(RMS)}$	6	A
V_{DRM}/V_{RRM}	600 and 800	V
T_{jmax}	150	°C

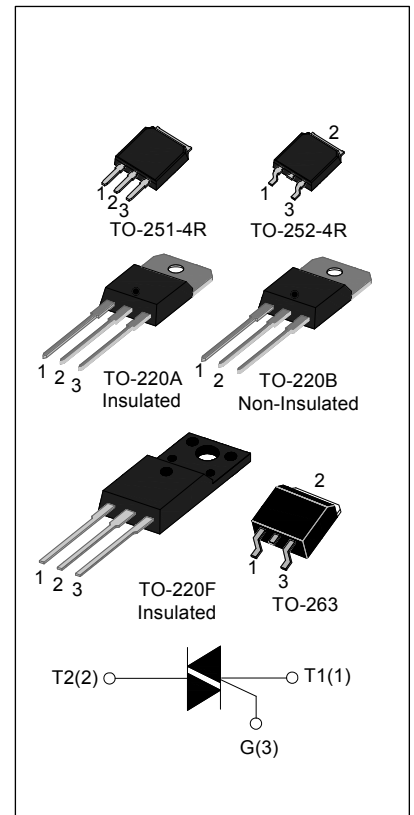

ABSOLUTE MAXIMUM RATINGS

Parameter	Symbol	Value	Unit
Storage junction temperature range	T_{stg}	-40-150	°C
Operating junction temperature range	T_j	-40-150	°C
Repetitive peak off-state voltage($T_j=25^\circ\text{C}$)	V_{DRM}	600/800	V
Repetitive peak reverse voltage($T_j=25^\circ\text{C}$)	V_{RRM}	600/800	V
Non repetitive surge peak Off-state voltage	V_{DSM}	$V_{DRM} + 100$	V
Non repetitive peak reverse voltage	V_{RSM}	$V_{RRM} + 100$	V
RMS on-state current	TO-251-4R/ TO-252-4R ($T_C=100^\circ\text{C}$)	6	A
	TO-220A(Ins)/ TO-220F(Ins) ($T_C=96^\circ\text{C}$)		
	TO-220B(Non-Ins) ($T_C=107^\circ\text{C}$)		

RMS on-state current	TO-263 (T _C =113°C)	I _{T(RMS)}	6	A
Non repetitive surge peak on-state current (full cycle, F=50Hz)		I _{TSM}	60	A
I ² t value for fusing (tp=10ms)		I ² t	21	A ² s
Critical rate of rise of on-state current (I _G =2×I _{GT})		di/dt	50	A/μs
Peak gate current		I _{GM}	4	A
Average gate power dissipation		P _{G(AV)}	1	W
Peak gate power		P _{GM}	5	W

ELECTRICAL CHARACTERISTICS (T_j=25°C unless otherwise specified)

Symbol	Test Condition	Quadrant		Value				Unit
				T0610H	T0620H	T0635H	T0650H	
I _{GT}	V _D =12V R _L =33Ω	I - II -III	MAX	10	20	35	50	mA
V _{GT}		I - II -III	MAX	1.3				V
V _{GD}	V _D =V _{DRM} T _j =150°C R _L =3.3KΩ	I - II -III	MIN	0.2				V
I _L	I _G =1.2I _{GT}	I - III	MAX	20	40	50	70	mA
		II		35	55	70	100	
I _H	I _T =100mA		MAX	20	30	45	60	mA
dV/dt	V _D =2/3V _{DRM} R _{GK} =1KΩ T _j =150°C		MIN	200	500	1000	1500	V/μs

STATIC CHARACTERISTICS

Symbol	Parameter		Value(MAX)	Unit
V _{TM}	I _{TM} =8.5A tp=380μs	T _j =25°C	1.4	V
I _{DRM}	V _D =V _{DRM} V _R =V _R RM	T _j =25°C	5	μA
I _R RM		T _j =150°C	1	mA

THERMAL RESISTANCES

Symbol	Parameter	Value	Unit	
$R_{th(j-c)}$	junction to case(AC)	TO-251-4R/ TO-252-4R	1.9	°C/W
		TO-220A(Ins)	2.7	
		TO-220B(Non-Ins)	1.8	
		TO-220F(Ins)	2.8	
		TO-263	1.5	

ORDERING INFORMATION

<p>T</p> <p>Triacs</p> <p>$I_{T(RMS)}:6A$</p> <p>10: $I_{GT1-3} \leq 10mA$</p> <p>20: $I_{GT1-3} \leq 20mA$</p> <p>35: $I_{GT1-3} \leq 35mA$</p> <p>50: $I_{GT1-3} \leq 50mA$</p>	<p>06</p>	<p>20</p>	<p>H</p> <p>High junction temperature</p>	<p>-6</p> <p>6: $V_{DRM} / V_{RRM} \geq 600V$</p> <p>8: $V_{DRM} / V_{RRM} \geq 800V$</p>	<p>F</p> <p>E: TO-263</p> <p>A: TO-220A(Ins)</p> <p>F: TO-220F(Ins)</p> <p>B: TO-220B(Non-Ins)</p> <p>H: TO-251-4R K: TO-252-4R</p>
-------------------------------------------------------------------------------------------------------------------------------------------------------------------------------------------------------------------------------------------------	------------------	------------------	--------------------------------------------------	------------------------------------------------------------------------------------------------------------------------	--------------------------------------------------------------------------------------------------------------------------------------------

PACKAGE MECHANICAL DATA

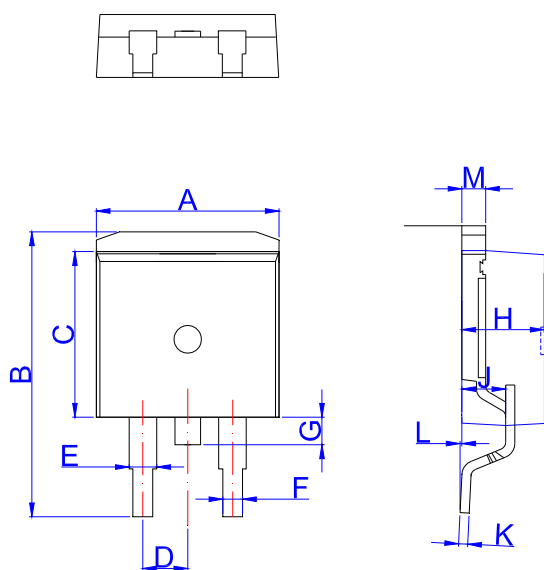

TO-263

Ref.	Dimensions					
	Millimeters			Inches		
	Min.	Typ.	Max.	Min.	Typ.	Max.
A	9.90		10.20	0.390		0.402
B	14.70		15.80	0.579		0.622
C	9.4		9.6	0.37		0.378
D		2.54			0.100	
E	1.20		1.40	0.047		0.055
F	0.75		0.85	0.029		0.033
G			1.75			0.069
H	4.40		4.70	0.173		0.185
J	2.30		2.70	0.091		0.106
K	0.38		0.55	0.015		0.022
L	0	0.10	0.25	0	0.004	0.010
M	1.25		1.35	0.049		0.053

PACKAGE MECHANICAL DATA

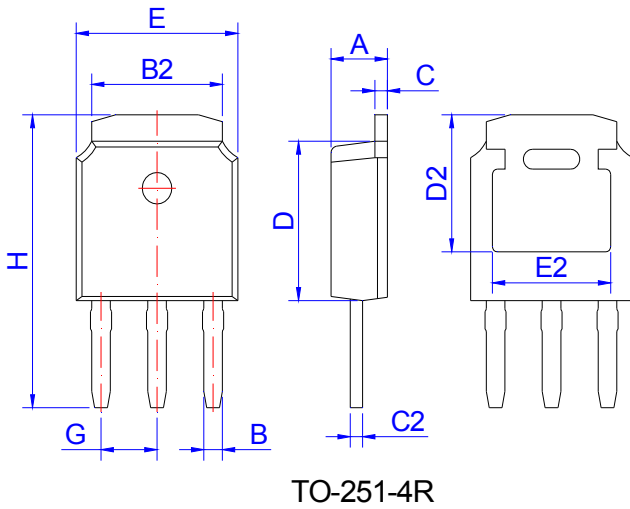

Ref.	Dimensions					
	Millimeters			Inches		
	Min.	Typ.	Max.	Min.	Typ.	Max.
A	2.10	2.30	2.50	0.083	0.091	0.098
B	0.66	0.76	0.86	0.026	0.030	0.034
B2	5.15	5.33	5.48	0.203	0.210	0.216
C	0.44	0.51	0.58	0.017	0.020	0.023
C2	0.44	0.51	0.58	0.017	0.020	0.023
D	5.90	6.10	6.30	0.232	0.240	0.248
D2	5.30 REF			0.209 REF		
E	6.40	6.60	6.80	0.252	0.260	0.268
E2	4.83 REF			0.190 REF		
G	2.19	2.29	2.39	0.086	0.090	0.094
H	10.60	11.20	11.80	0.417	0.441	0.465

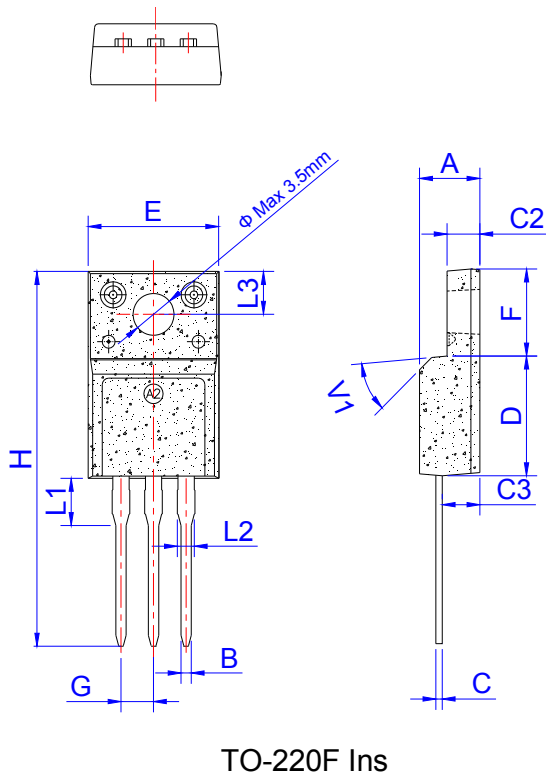

Ref.	Dimensions					
	Millimeters			Inches		
	Min.	Typ.	Max.	Min.	Typ.	Max.
A	4.50		4.90	0.177		0.193
B	0.74	0.80	0.83	0.029	0.031	0.033
C	0.47		0.65	0.019		0.026
C2	2.45		2.75	0.096		0.108
C3	2.60		3.00	0.102		0.118
D	8.80		9.30	0.346		0.366
E	9.80		10.4	0.386		0.410
F	6.40		6.80	0.252		0.268
G		2.54			0.1	
H	28.0		29.8	1.102		1.173
L1		3.63			0.143	
L2	1.14		1.70	0.045		0.067
L3		3.30			0.130	
V1		45°			45°	

PACKAGE MECHANICAL DATA

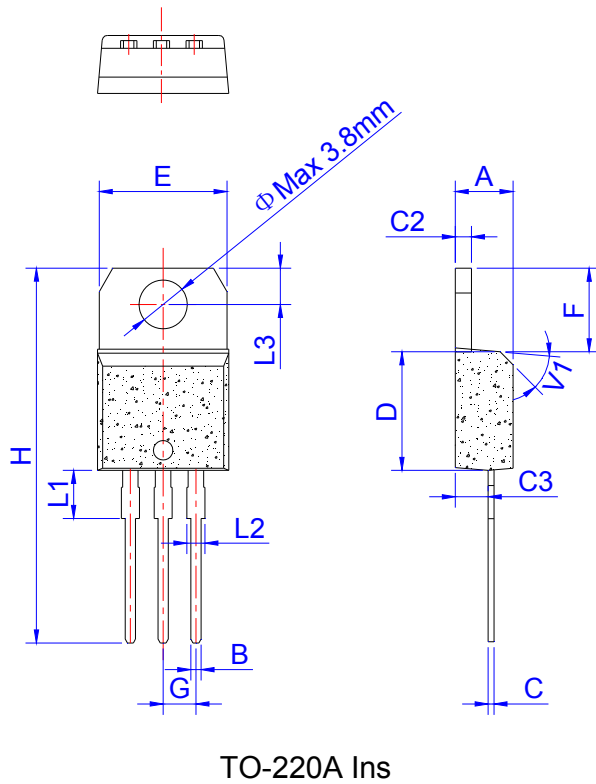

Ref.	Dimensions					
	Millimeters			Inches		
	Min.	Typ.	Max.	Min.	Typ.	Max.
A	4.40		4.60	0.173		0.181
B	0.61		0.88	0.024		0.035
C	0.46		0.70	0.018		0.028
C2	1.21		1.32	0.048		0.052
C3	2.40		2.72	0.094		0.107
D	8.60		9.70	0.339		0.382
E	9.80		10.4	0.386		0.409
F	6.55		6.95	0.258		0.274
G		2.54			0.1	
H	28.0		29.8	1.102		1.173
L1		3.75			0.148	
L2	1.14		1.70	0.045		0.067
L3	2.65		2.95	0.104		0.116
V1		45°			45°	

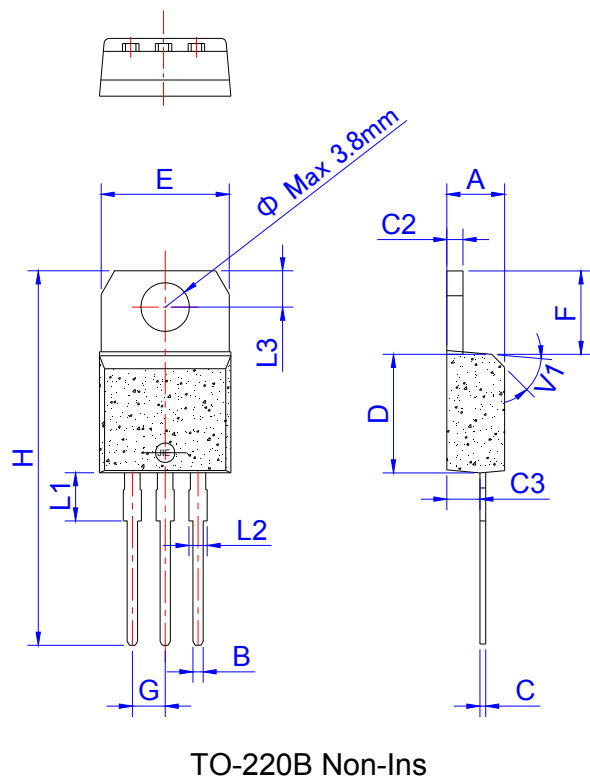

Ref.	Dimensions					
	Millimeters			Inches		
	Min.	Typ.	Max.	Min.	Typ.	Max.
A	4.40		4.60	0.173		0.181
B	0.61		0.88	0.024		0.035
C	0.46		0.70	0.018		0.028
C2	1.21		1.32	0.048		0.052
C3	2.40		2.72	0.094		0.107
D	8.60		9.70	0.339		0.382
E	9.60		10.4	0.378		0.409
F	6.20		6.60	0.244		0.260
G		2.54			0.1	
H	28.0		29.8	1.102		1.173
L1		3.75			0.148	
L2	1.14		1.70	0.045		0.067
L3	2.65		2.95	0.104		0.116
V1		45°			45°	

PACKAGE MECHANICAL DATA

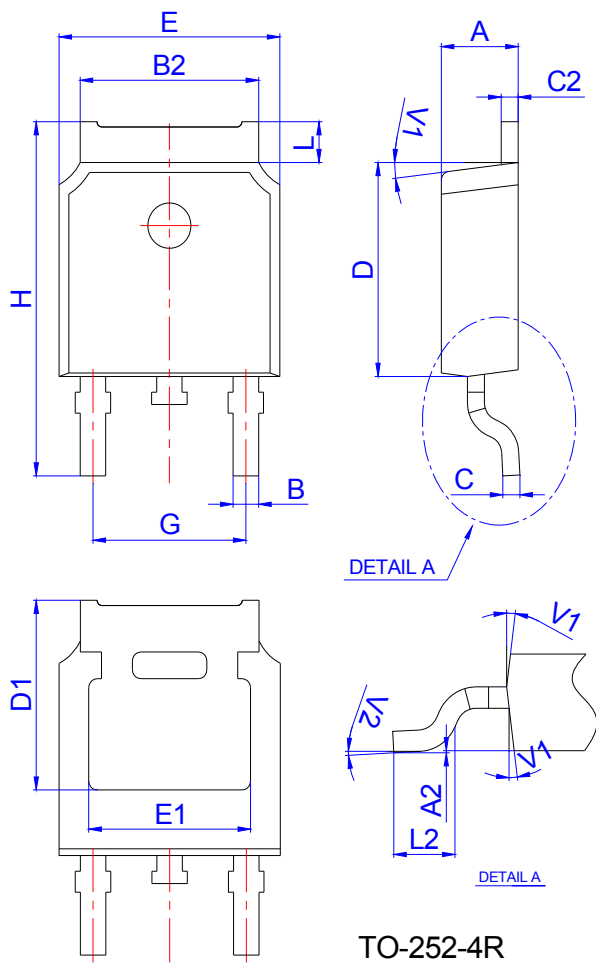

Ref.	Dimensions					
	Millimeters			Inches		
	Min.	Typ.	Max.	Min.	Typ.	Max.
A	2.10		2.50	0.083		0.098
A2	0		0.10	0		0.004
B	0.66		0.86	0.026		0.034
B2	5.18		5.48	0.202		0.216
C	0.40		0.60	0.016		0.024
C2	0.44		0.58	0.017		0.023
D	5.90		6.30	0.232		0.248
D1	5.30REF			0.209REF		
E	6.40		6.80	0.252		0.268
E1	4.63			0.182		
G	4.47		4.67	0.176		0.184
H	9.50		10.70	0.374		0.421
L	1.09		1.21	0.043		0.048
L2	1.35		1.65	0.053		0.065
V1		7°			7°	
V2	0°		6°	0°		6°

FIG.1: Maximum power dissipation versus RMS on-state current

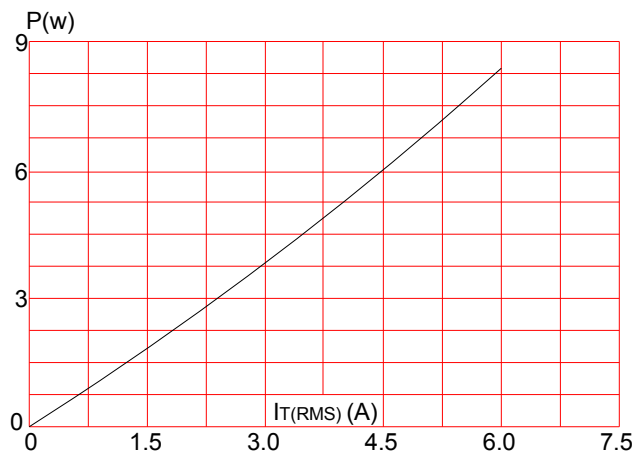

FIG.2: RMS on-state current versus case temperature

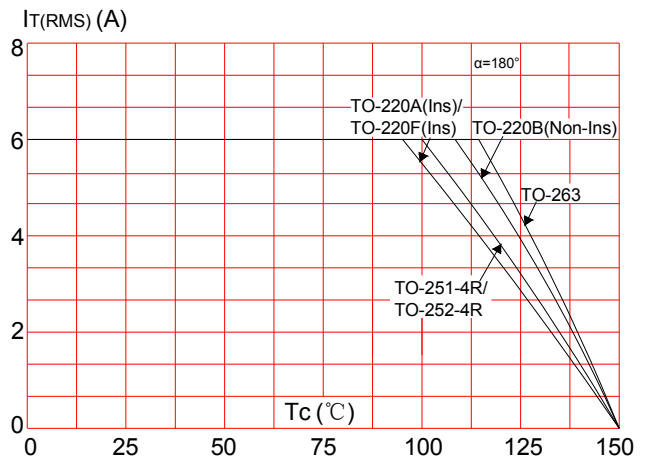

FIG.3: Surge peak on-state current versus number of cycles

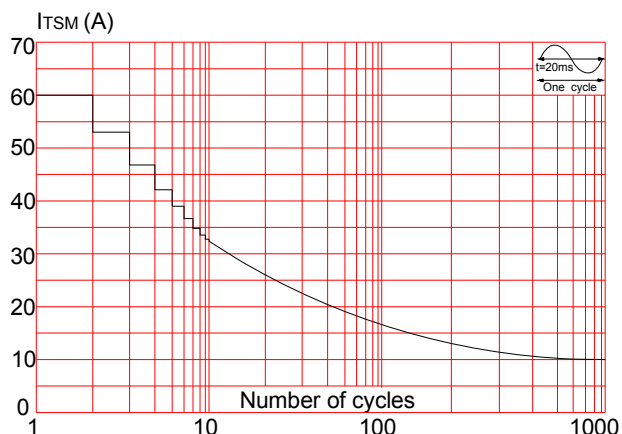

FIG.5: Non-repetitive surge peak on-state current for a sinusoidal pulse with width $t_p < 20\text{ms}$, and corresponding value of I^2t ($dI/dt < 50\text{A}/\mu\text{s}$)

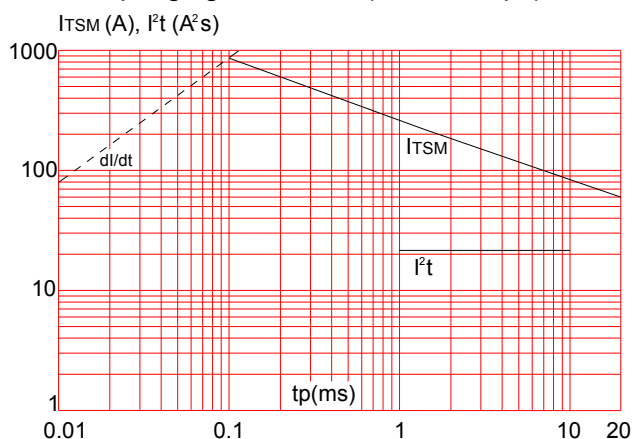

FIG.4: On-state characteristics (maximum values)

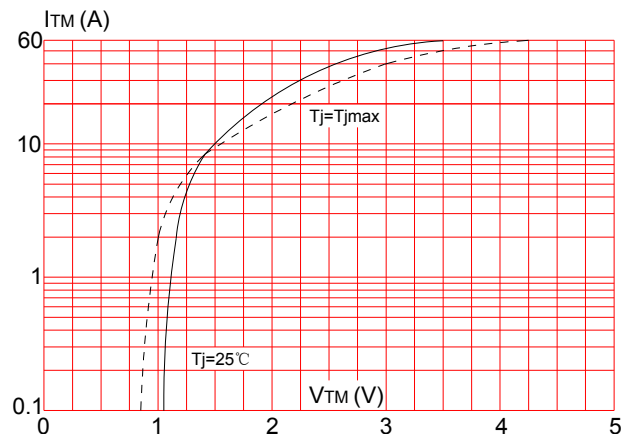
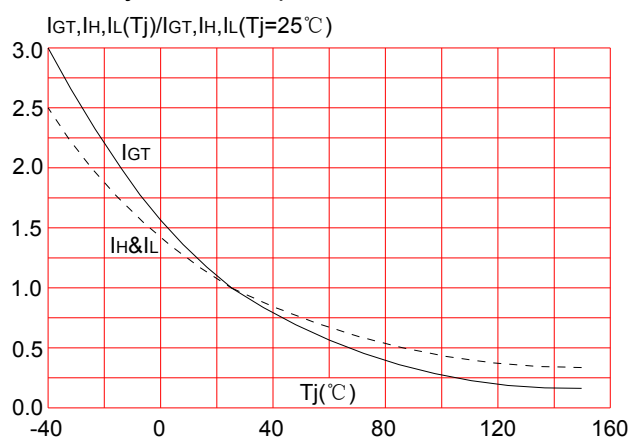

FIG.6: Relative variations of gate trigger current, holding current and latching current versus junction temperature



Information furnished in this document is believed to be accurate and reliable. However, Jiangsu JieJie Microelectronics Co.,Ltd assumes no responsibility for the consequences of use without consideration for such information nor use beyond it.

Information mentioned in this document is subject to change without notice, apart from that when an agreement is signed, Jiangsu JieJie complies with the agreement.

Products and information provided in this document have no infringement of patents. Jiangsu JieJie assumes no responsibility for any infringement of other rights of third parties which may result from the use of such products and information.

This document is the eighth version which is made in 29-Jan.-2018. This document supersedes and replaces all information previously supplied.

 is a registered trademark of Jiangsu JieJie Microelectronics Co.,Ltd.

Copyright ©2018 Jiangsu JieJie Microelectronics Co.,Ltd. Printed All rights reserved.