

Aug.1.2022 Copyright 2022 HIROSE ELECTRIC CO., LTD. All Rights Reserved.  
In case of consideration for using Automotive equipment / device which demand high reliability, kindly contact our sales window correspondents.

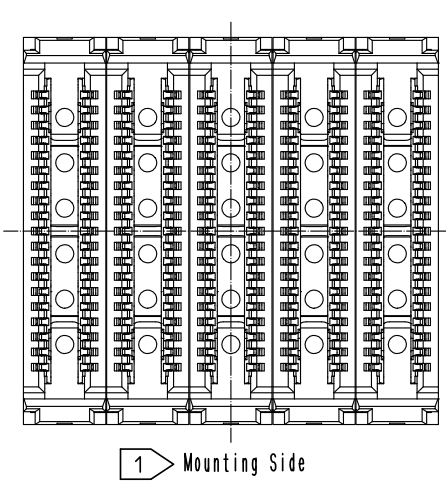

- Note.
- 1 Mounting side is mated with Plug-M:IT8M-120P-BGA-H(\*\*) and fixed with the latch.
  - 2 Mating side is mated with Plug-D:IT8D-120P-BGA-H(\*\*).
  - 3 Lot No. shall be marked at the indicated position.
  - 4 IT8 Series apply GSSG. pin assign as shown. Twisted pairs are indicated by the hatch marks. Twisted pairs are twisted in the center to reduce FEXT.
  - 5 The indicated mother board and daughter card shall be fastened to the additional reinforcements to prevent the stress on IT8\*-120P-BGA-H(\*\*) solder joints.
  - 6 This product consists of 120 signal contacts and 70 ground contacts.
  - 7 The spacer height of this product assembled with mounted IT8M-120P-BGA-H(\*\*) and IT8D-120P-BGA-H(\*\*) shall be indicated in Table 1.

Spacer height (X)	32	33	34
Plug-D (Detachable Side)	IT8D-***P-BGA-0H(**)	IT8D-***P-BGA-0H(**)	IT8D-***P-BGA-1H(**)
Interposer	IT8-***S-32H(**)		
Plug-M (Mounting Side)	IT8M-***P-BGA-0H(**)	IT8M-***P-BGA-1H(**)	IT8M-***P-BGA-1H(**)

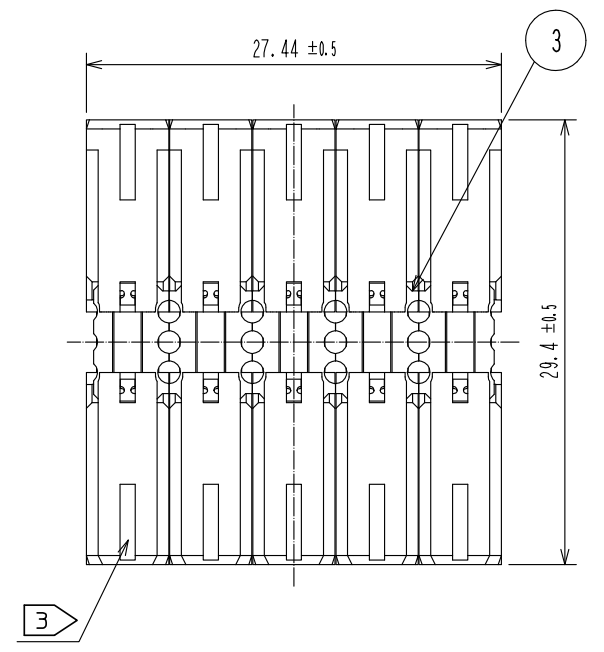
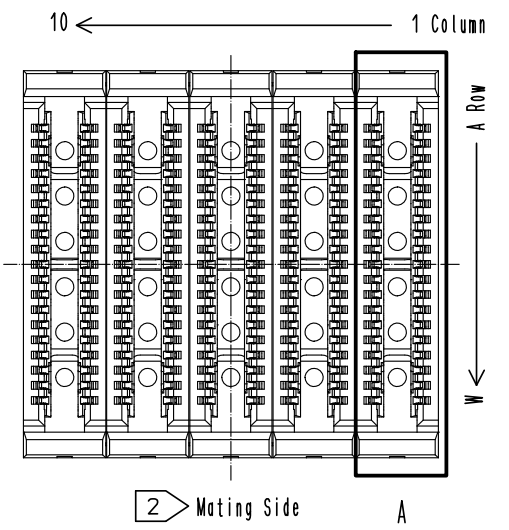
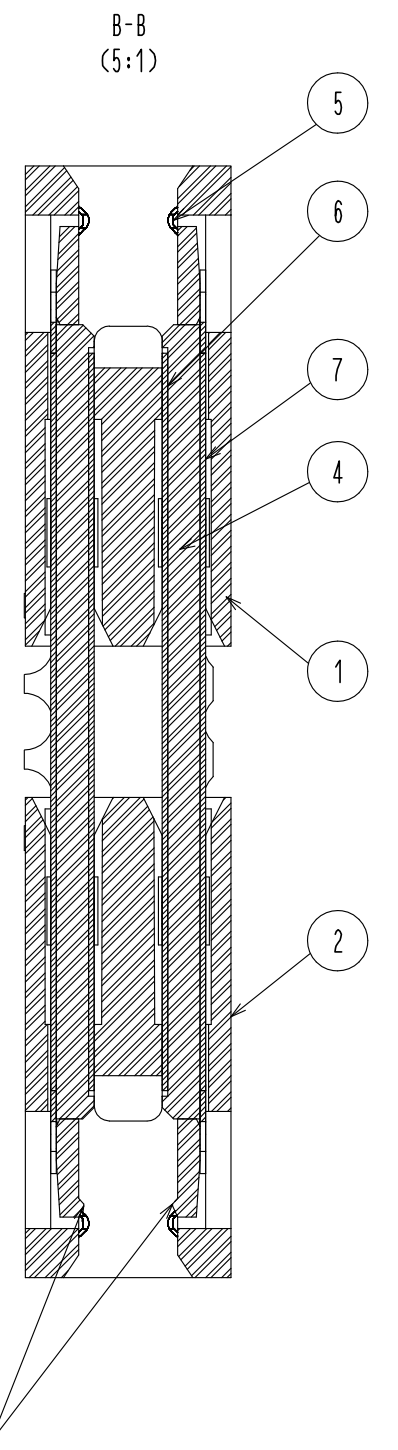
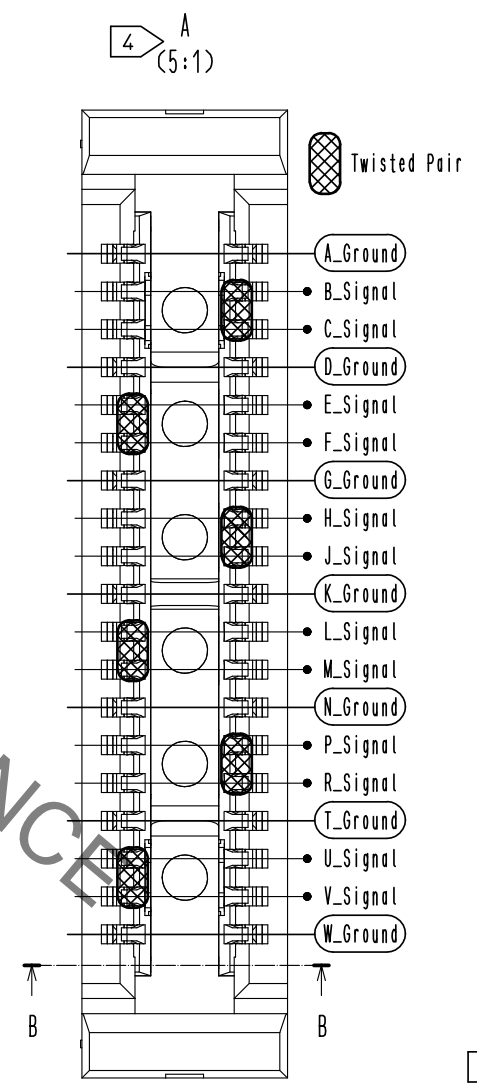
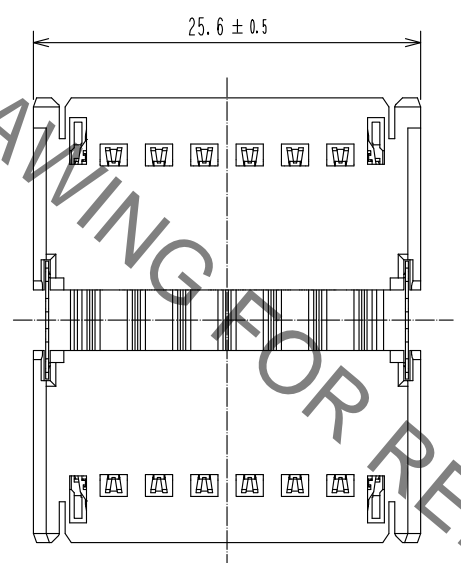

4	LCP	BLACK. UL94V-0	7	SUS				
3	SUS		6	SUS				
2	PPS	BLACK. UL94V-0	5	Copper Alloy	Contact area:Nickel 1.27µm min.+Gold 0.76µm min.			
1	PPS	GRAY. UL94V-0			Other area:Nickel 1.27µm min.			
NO.	MATERIAL	FINISH . REMARKS	NO.	MATERIAL	FINISH . REMARKS			
UNITS	mm	SCALE	2 : 1	COUNT	DESCRIPTION OF REVISIONS	DESIGNED	CHECKED	DATE
APPROVED :MK. EZAKI		17.03.23		DRAWING NO.		EDC-370995-00-00		
CHECED :YS. TAKEUCHI		17.03.23		PART NO.		IT8-120S-32H		
DESIGNED :TH. SANO		17.03.22		CODE NO.		CL636-3512-0-00		
DRAWN :CHUNKAI YANG		17.03.22						

HRS DRAWING FOR REFERENCE

Aug.1.2022 Copyright 2022 HIROSE ELECTRIC CO., LTD. All Rights Reserved.  
 In case of consideration for using Automotive equipment / device which demand high reliability, kindly contact our sales window correspondents.

## IT8 Assembly Process

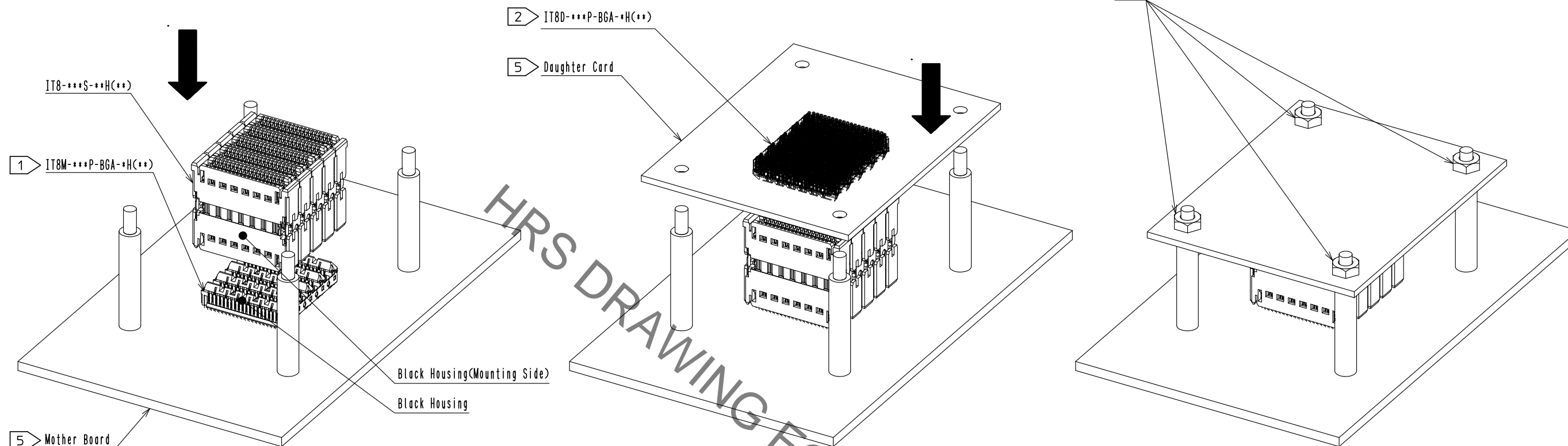

1) Insert mounting side of Interposer(IT8-\*\*\*S-\*\*H(\*\*)) by pressing on top of Interposer into reflowed Mounting Plug(IT8M-\*\*\*P-BGA-\*\*H(\*\*)) having black housings.

2) Insert Detachable Plug(IT8D-\*\*\*P-BGA-\*\*H(\*\*)) having gray housings into mating side of Interposer(IT8-\*\*\*S-\*\*H(\*\*)).

3) Install and tighten nuts to fix mated Detachable Plug after completion of mating.

## IT8 Mated Condition

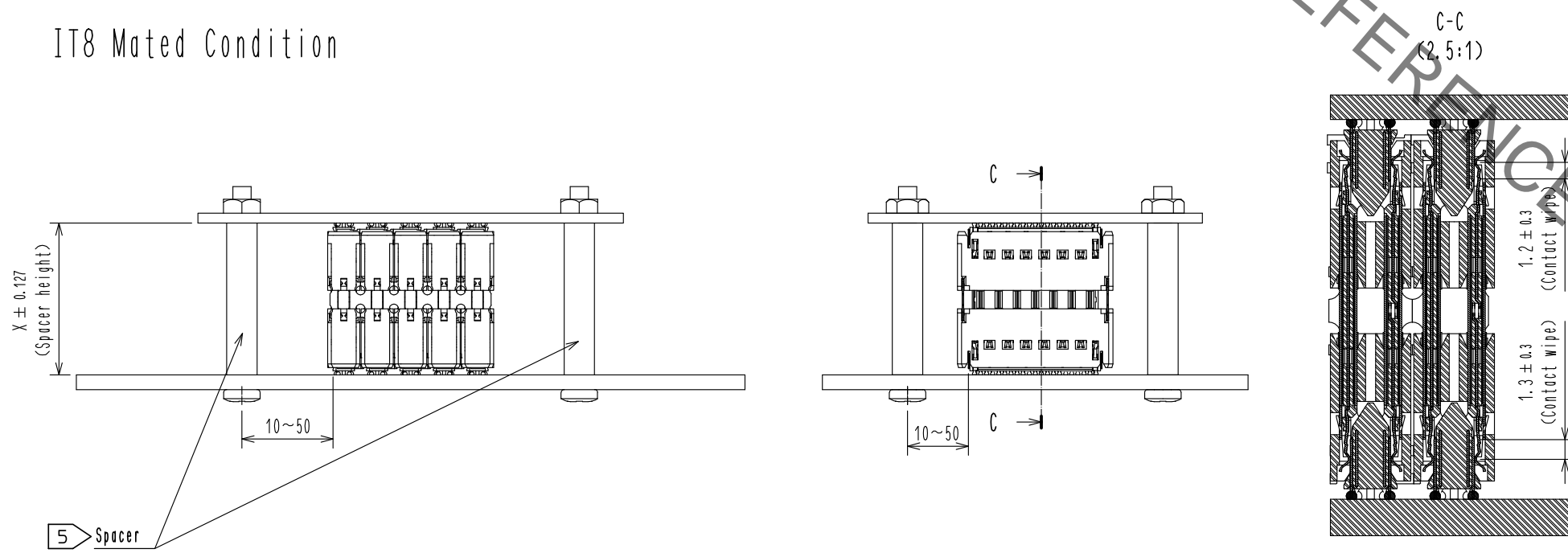

<b>HRS</b>	DRAWING NO.	EDC-370995-00-00
	PART NO.	IT8-120S-32H
	CODE NO.	CL636-3512-0-00
		2/2