



SS34L~SS320L

Surface Mount Low VF Schottky Rectifiers

Features

- Low profile package
- Ideal for automated placement
- Ultrafast reverse recovery time
- Low power losses, high efficiency
- Low forward voltage drop
- High surge capability
- High temperature soldering:
260°C/10 seconds at terminals
- Component in accordance to
RoHS 2002/95/1 and WEEE 2002/96/EC

Mechanical Date

- **Case:** JEDEC DO-214AC (SMA) molded plastic
- **Terminals:** Solder plated, solderable per J-STD-002B and JESD22-B102D
- **Polarity:** Laser band denotes cathode end

SMA/DO-214AC

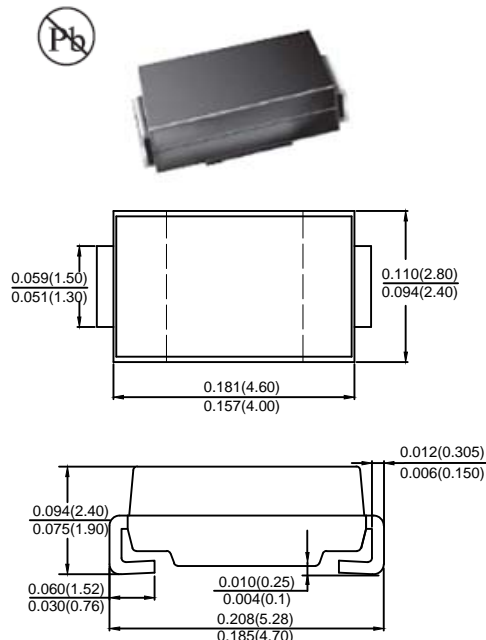

Dimensions in inches and (millimeters)

Maximum Ratings & Thermal Characteristics

($T_A = 25^\circ\text{C}$ unless otherwise noted)

Type Number	SYMBOL	SS 34L	SS 35L	SS 36L	SS 38L	SS 310L	SS 315L	SS 320L	Unit
Maximum Recurrent Peak Reverse Voltage	V_{RRM}	40	50	60	80	100	150	200	V
Maximum RMS Voltage	V_{RMS}	28	35	42	56	70	105	140	V
Maximum DC Blocking Voltage	V_{DC}	40	50	60	80	100	150	200	V
Average Rectified Output Current @ $T_L = 100^\circ\text{C}$	$I_{F(AV)}$	3.0							A
Peak Forward Surge Current 8.3ms Single half sine-wave superimposed on rated load (JEDEC Method)	I_{FSM}	80							A
Rating for fusing ($t < 8.3\text{ms}$)	I^2t	26.56							A^2s
Forward Voltage @ $I_F = 3.0\text{A}$ (Note1)	V_{FM}	0.45		0.55		0.75		0.85	V
Peak Reverse Current @ $T_A = 25^\circ\text{C}$	I_R	0.1			0.05				mA
At Rated DC Blocking Voltage @ $T_A = 100^\circ\text{C}$		10			5				
Typical Junction Capacitance	C_J	28.0							pF
Typical Thermal Resistance per leg (Note 2)	$R_{\theta JL}$	88							$^\circ\text{C}/\text{W}$
Operating Temperature Range	T_J	-55 to +150							$^\circ\text{C}$
Storage Temperature Range	T_{STG}	-55 to +150							$^\circ\text{C}$

Note: 1. Pulse Test with $PW = 300\mu\text{s}$, 1% Duty Cycle.

2. Mounted on P.C. Board with 5.0 mm^2 (0.13mm thick) copper pad areas.



SS34L~SS320L Surface Mount Low VF Schottky Rectifiers

Characteristic Curves ($T_A=25^\circ\text{C}$ unless otherwise noted)

Fig. 1 Forward Current Derating Curve

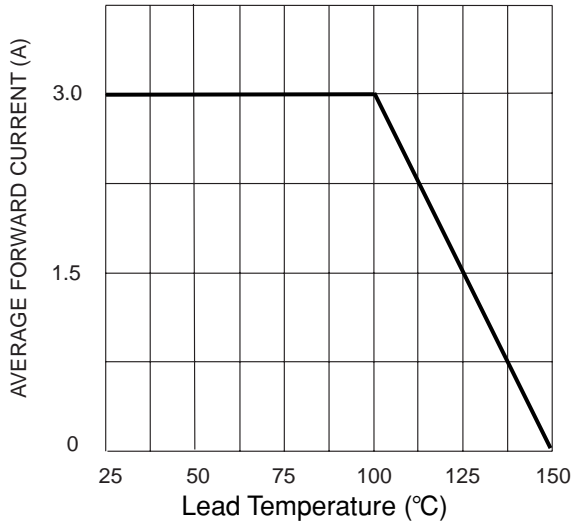

Fig. 2 Typ. Forward Characteristics

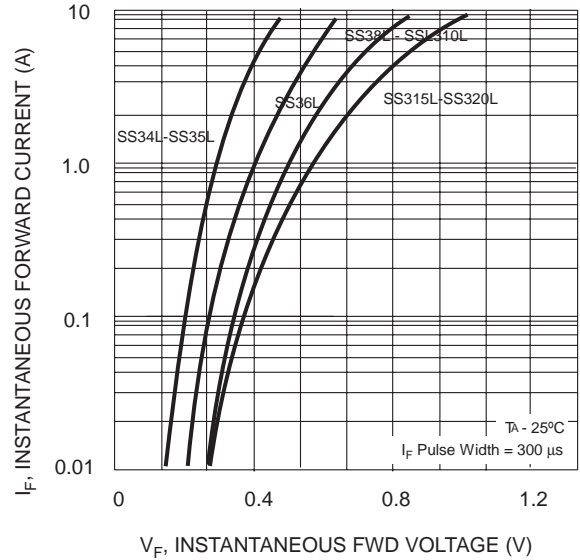

Fig. 3 Max Non-Repetitive Peak Fwd Surge Current

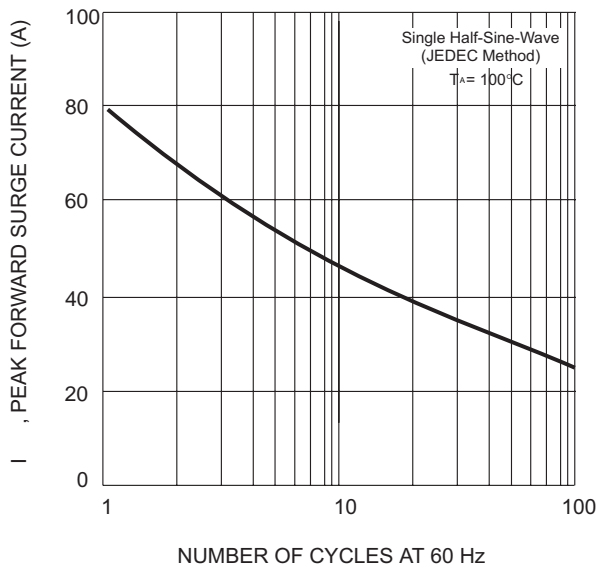
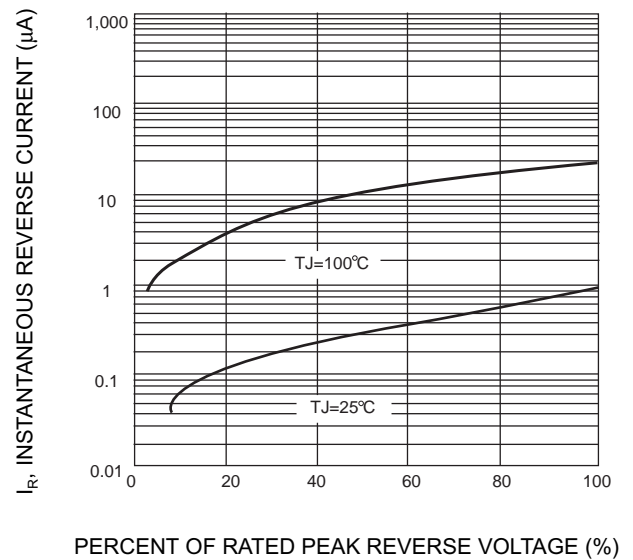

Fig. 4 Typical Reverse Characteristics (per element)



SMA PAD LAYOUT

