

UNA0233

Transistor array to drive the small motor

■ Features

- Small and lightweight
- Low power consumption
- Low-voltage drive
- With 6 elements incorporated

■ Applications

- For motor drives
- Small motor drive circuits in general

■ Absolute Maximum Ratings (Ta=25±3°C)

Parameter	Symbol	Ratings	Unit
Collector to base voltage	V_{CBO}	± 10	V
Collector to emitter voltage	V_{CEO}	± 10	V
Emitter to base voltage	V_{EBO}	± 7	V
Collector current	I_C	± 0.5	A
Peak collector current	I_{CP}	± 1	A
Total power dissipation	P_T^*	0.5	W
Junction temperature	T_j	150	°C
Storage temperature	T_{sig}	-55 to +150	°C

Note: ± marks used above: +: NPN part, -: PNP part

* $T_C = 25^\circ\text{C}$ only when the elements are active

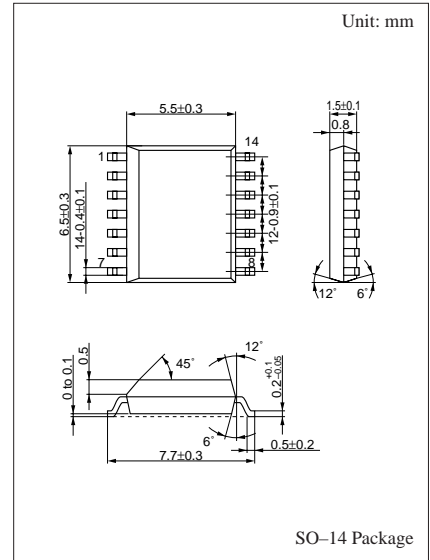

Internal Connection

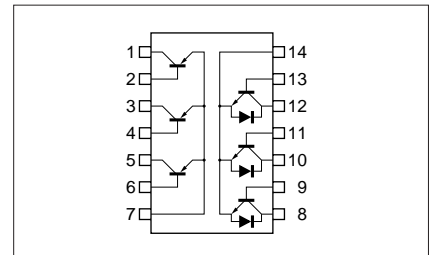

■ Electrical Characteristics ($T_a=25^\circ\text{C}$)

Parameter	Symbol	Conditions	min	typ	max	Unit
Collector to base voltage	V_{CBO}	(NPN) $I_{\text{C}} = 10\mu\text{A}$, $I_{\text{E}} = 0$	10			V
		(PNP) $I_{\text{C}} = -10\mu\text{A}$, $I_{\text{E}} = 0$	-10			
Collector to emitter voltage	V_{CEO}	(NPN) $I_{\text{C}} = 1\text{mA}$, $I_{\text{B}} = 0$	10			V
		(PNP) $I_{\text{C}} = -1\text{mA}$, $I_{\text{B}} = 0$	-10			
Emitter to base voltage	V_{EBO}	(NPN) $I_{\text{E}} = 10\mu\text{A}$, $I_{\text{C}} = 0$	7			V
Collector cutoff current	I_{CBO}	(NPN) $V_{\text{CB}} = 7\text{V}$, $I_{\text{E}} = 0$			1	μA
Forward current transfer ratio	h_{FE}	(NPN) $V_{\text{CE}} = 2\text{V}$, $I_{\text{C}} = 200\text{mA}^*$	200		800	
		(PNP) $V_{\text{CE}} = -2\text{V}$, $I_{\text{C}} = -100\text{mA}^*$	200		450	
Collector to emitter saturation voltage	$V_{\text{CE(sat)}}$	(NPN) $I_{\text{C}} = 1\text{A}$, $I_{\text{B}} = 25\text{mA}^*$			0.4	V
		(PNP) $I_{\text{C}} = -1\text{A}$, $I_{\text{B}} = -25\text{mA}^*$			-0.4	
Transition frequency	f_{T}	(NPN) $V_{\text{CB}} = 6\text{V}$, $I_{\text{E}} = -50\text{mA}$, $f = 200\text{MHz}$		120		MHz
		(PNP) $V_{\text{CB}} = -6\text{V}$, $I_{\text{E}} = 50\text{mA}$, $f = 200\text{MHz}$		190		
Collector output capacitance	C_{ob}	(NPN) $V_{\text{CB}} = 6\text{V}$, $I_{\text{E}} = 0$, $f = 1\text{MHz}$		25		pF
		(PNP) $V_{\text{CB}} = -10\text{V}$, $I_{\text{E}} = 0$, $f = 1\text{MHz}$		65		
Forward voltage	V_{F}	(NPN) $I_{\text{F}} = 0.5\text{A}$			1.3	V

*Pulse measurement