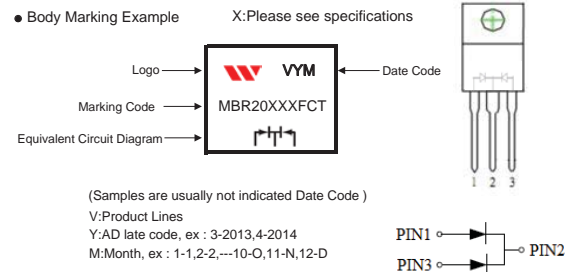

20A SW cth_mBUfjYf RYWjZYfg- 40V~200V

PRIMARY CHARACTERISTICS	
V_{RRM}	40V~200V
$I_{F(AV)}$	20A
V_F	0.65V,0.8V,0.85V,0.92V
$T_{J,Max}$	150°C

ITO-220 PACKAGE

FEATURES

- Metal silicon junction, majority carrier conduction
- Low power loss, high efficiency
- High current capability
- For use in low voltage, high frequency inverters free wheeling, and polarity protection applications.
- Moisture Sensitivity Level 1

MECHANICAL DATA

- Case : Molded plastic, ITO-220
- Polarity : Shown above
- Terminals : Plated terminals, solderable per MIL-STD-750, Method 2026
- Epoxy : UL94-V0 rated flame retardant

MAXIMUM RATINGS AND ELECTRICAL CHARACTERISTICS

Ratings at 25°C ambient temperature unless otherwise specified. Single phase, half wave, 60 Hz, resistive or inductive load.

For capacitive load, derate current by 20%

PARAMETER	SYMBOL	MBR 20400CT	MBR 20450CT	MBR 20500CT	MBR 20600CT	MBR 20800CT	MBR 20900CT	MBR 201000CT	MBR 201500CT	MBR 202000CT	UNITS
Maximum Recurrent Peak Reverse Voltage	V_{RRM}	40	45	50	60	80	90	100	150	200	V
Maximum RMS Voltage	V_{RMS}	28	31.5	35	42	56	63	70	105	140	V
Maximum DC Blocking Voltage	V_{DC}	40	45	50	60	80	90	100	150	200	V
Maximum Average Forward Current (See fig.1)	$I_{F(AV)}$	20									A
Peak Forward Surge Current : 8.3ms single half sine-wave superimposed on rated load (JEDEC method)	I_{FSM}	150									A
Maximum Forward Voltage at 10A, per leg	V_F	0.65	0.8		0.85			0.92			V
Maximum DC Reverse Current $T_J=25^\circ\text{C}$ at Rated DC Blocking Voltage $T_J=125^\circ\text{C}$	I_R	0.05 20			0.02 20						mA
Typical Thermal Resistance	$R_{\theta JC}$	2									°C / W
Operating Junction and Storage Temperature Range	T_J, T_{STG}	-50 to + 150									°C
Junction Capacitance (Note)	C_J	700	500		400			300	250		pF

Note:

1. Measured at 1.0 MHz and applied reverse voltage of 4.0Vdc;

RATING AND CHARACTERISTIC CURVES

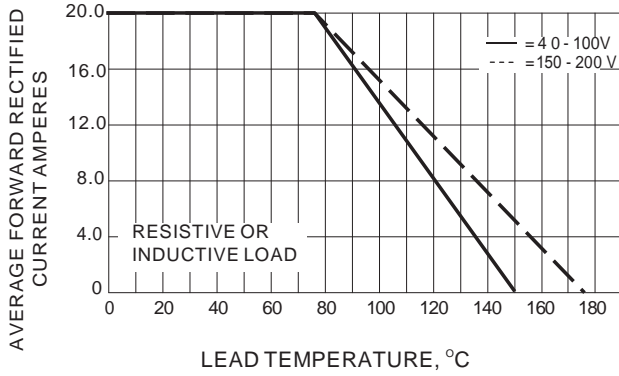

Fig.1- FORWARD CURRENT DERATING CURVE

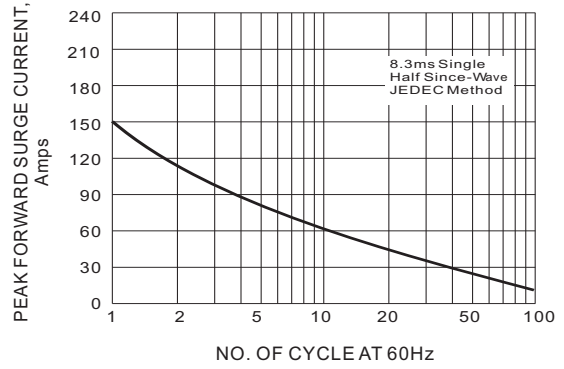

Fig.2- MAXIMUM NON-REPETITIVE SURGE CURRENT

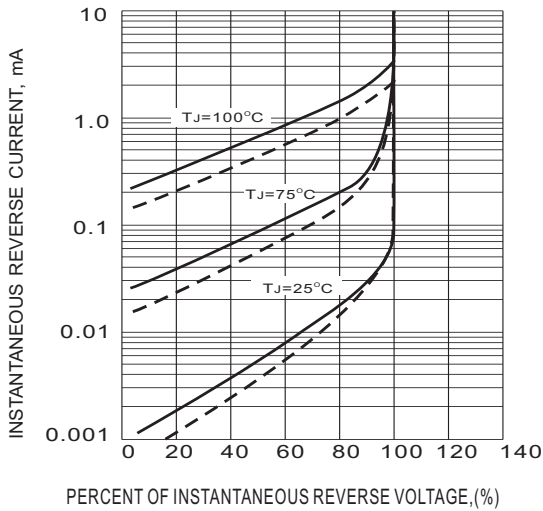

Fig.3- TYPICAL REVERSE CHARACTERISTICS

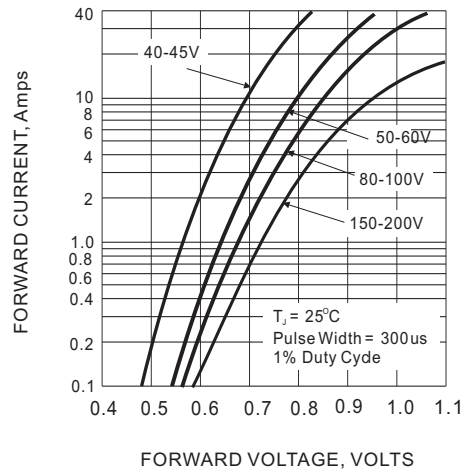
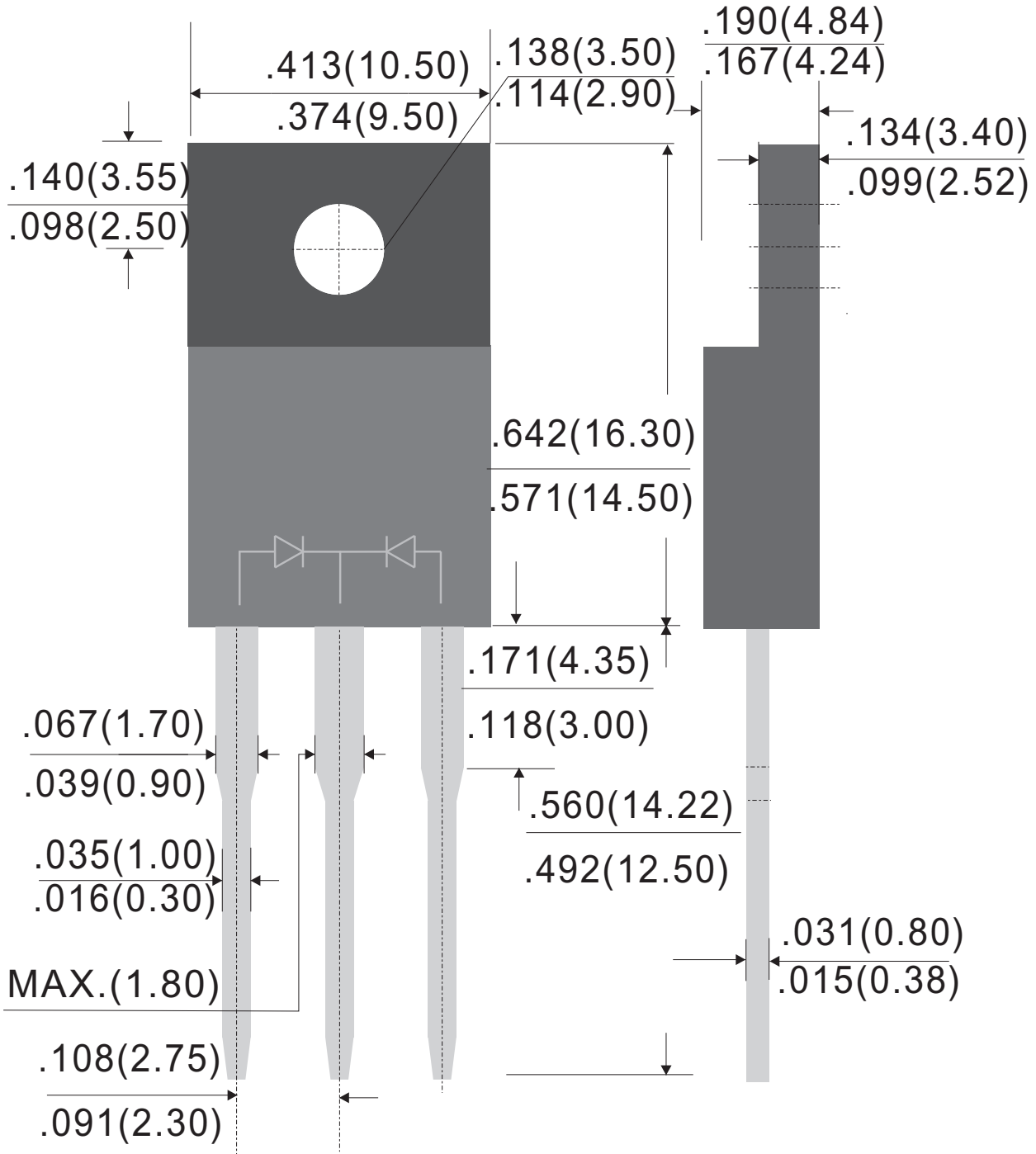

Fig.4- TYPICAL INSTANTANEOUS FORWARD CHARACTERISTICS



Outline Drawing

ITO-220(D)



Dimensions in inches and (millimeters)

Rev.I

Ordering Information:

Device PN	Packing
Part Number - ⁽¹⁾ G ⁽²⁾ -WS	Tube Packing:50pcs/Tube; 2000pcs/Box

- Note:** 1. Packing code: Empty is Tube Packing
2. RoHS product for packing code suffix "G"

*****Disclaimer*****

WILLAS reserves the right to make changes without notice to any product specification herein, to make corrections, modifications, enhancements or other changes. WILLAS or anyone on its behalf assumes no responsibility or liability for any errors or inaccuracies. Data sheet specifications and its information contained are intended to provide a product description only. "Typical" parameters which may be included on WILLAS data sheets and/ or specifications can and do vary in different applications and actual performance may vary over time. WILLAS does not assume any liability arising out of the application or use of any product or circuit.

This is the preliminary specification. WILLAS products are not designed, intended or authorized for use in medical, life-saving implant or other applications intended for life-sustaining or other related applications where a failure or malfunction of component or circuitry may directly or indirectly cause injury or threaten a life without expressed written approval of WILLAS. Customers using or selling WILLAS components for use in such applications do so at their own risk and shall agree to fully indemnify WILLAS Inc and its subsidiaries harmless against all claims, damages and expenditures.