

DESCRIPTION

The GLF72100 is an advanced technology fully integrated I_QSmart™ load switch device with True Reverse Current Blocking (TRCB) technology and the slew rate control of the output voltage.

The GLF72100 offers industry leading True Reverse Current Blocking (TRCB) performance, featuring an ultra-low threshold voltage. It minimizes reverse current flow in the event that the V_{OUT} pin voltage exceeds the V_{IN} voltage.

The GLF72100 has industry leading efficiency. It features a R_{ON} as low as 37 mΩ typical at 5.5 V, reducing power loss during conduction. The device also features ultra-low shutdown current (I_{SD}) to reduce power loss and battery drain in the off state. When EN is pulled low, and the output is grounded, the GLF72100 can achieve an I_{SD} as low as 20 nA typical at 5.5 V.

The GLF72100 load switch device supports an industry leading wide input voltage range and helps to improve operating life and system robustness. Furthermore, one device can be used in multiple voltage rail applications which helps to simplify inventory management and reduces operating cost.

The GLF72100 load switch device is small utilizing a chip scale package with 6 bumps in a 0.77 mm x 0.77 mm x 0.46 mm die size and a 0.4 mm pitch.

FEATURES

- True Reverse Current Blocking
- Ultra-Low I_Q: 0.45 uA Typ @ 5.5 V_{IN}
- Ultra-Low I_{SD}: 20 nA Typ @ 5.5 V_{IN}
- Low R_{ON}: 37 mΩ Typ @ 5.5 V_{IN}
- I_{OUT} Max: 2 A
- Wide Input Range: 1.5 V to 5.5 V
6 Vabs max
- Controlled Rise Time: 570 us at 3.3V_{IN}
- Internal EN Pull-Down Resistor on GLF72100,
- Ultra-Small: 0.77 mm x 0.77 mm

APPLICATIONS

- Mobile Devices
- Wearables
- Low Power Subsystems

PACKAGE

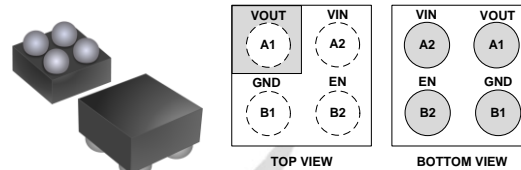

0.77 mm x 0.77 mm x 0.46 mm WLCSP

APPLICATION DIAGRAM

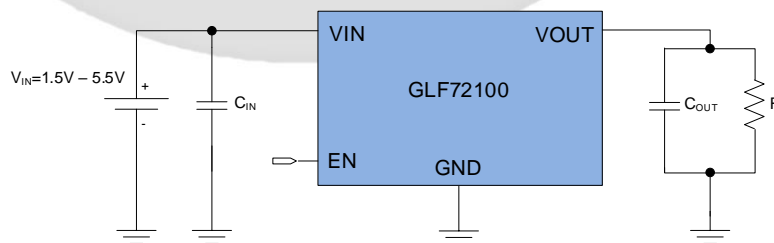

FUNCTIONAL BLOCK DIAGRAM

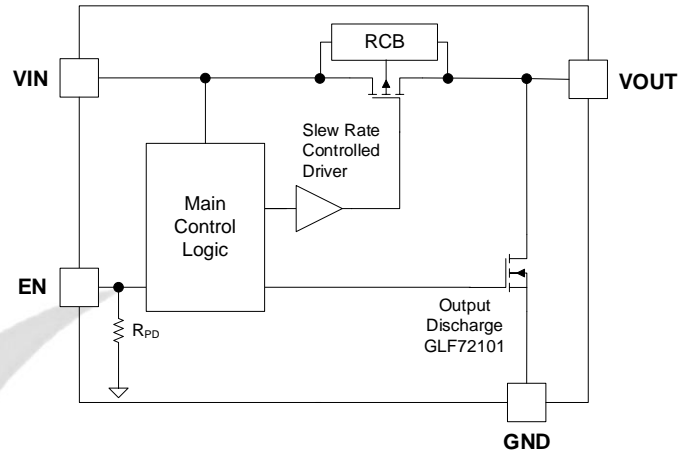
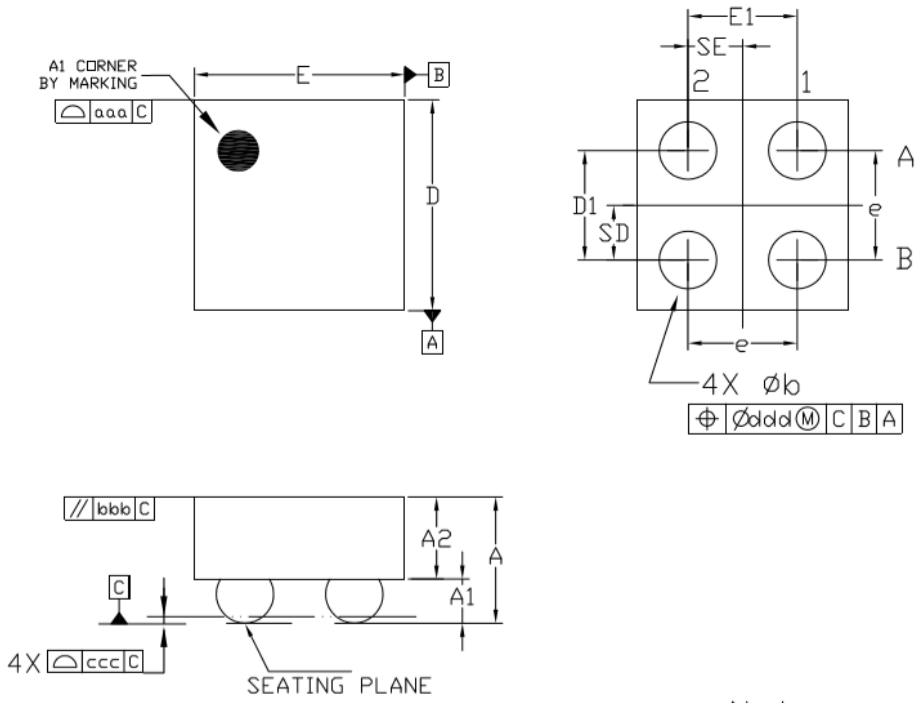

Figure 1. Functional Block Diagram

GLF
INTEGRATED POWER

PACKAGE OUTLINE



Dimensional Ref.			
REF.	Min.	Nom.	Max.
A	0.410	0.460	0.510
A1	0.135	0.160	0.185
A2	0.275	0.300	0.325
D	0.755	0.770	0.785
E	0.755	0.770	0.785
D1	0.350	0.400	0.450
E1	0.350	0.400	0.450
b	0.170	0.210	0.250
e	0.400 BSC		
SD	0.200 BSC		
SE	0.200 BSC		
Tol. of Form&Position			
aaa	0.10		
bbb	0.10		
ccc	0.05		
ddd	0.05		

Notes

1. ALL DIMENSIONS ARE IN MILLIMETERS (ANGLES IN DEGREES).
2. DIMENSIONING AND TOLERANCING PER ANSI Y14.5M-1994.