

Features

- Low cost
- Low leakage
- Low forward voltage drop
- High current capability

HF

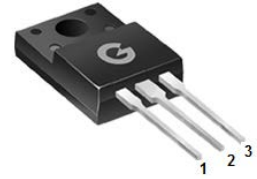
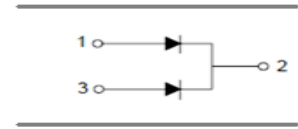

ITO-220AB

Mechanical Data

- Case: ITO-220AB
- Molding Compound: UL Flammability Classification Rating 94V-0
- Terminals: Matte tin-plated leads; solderability-per MIL-STD-202, Method 208

Ordering Information

| Part Number | Package | Shipping Quantity | Marking Code |
|-------------|-----------|-------------------|--------------|
| MUR2020FC | ITO-220AB | 50pcs / Tube | MUR2020FC |
| MUR2030FC | ITO-220AB | 50pcs / Tube | MUR2030FC |
| MUR2040FC | ITO-220AB | 50pcs / Tube | MUR2040FC |
| MUR2060FC | ITO-220AB | 50pcs / Tube | MUR2060FC |

Maximum Ratings (@ T_A = 25°C unless otherwise specified)

| Parameter | Symbol | MUR2020FC | MUR2030FC | MUR2040FC | MUR2060FC | Unit |
|--|--------------------|-----------|-----------|-----------|-----------|------|
| Peak Repetitive Reverse Voltage | V _{RRM} | 200 | 300 | 400 | 600 | V |
| RMS Reverse Voltage | V _{RMS} | 140 | 210 | 280 | 420 | V |
| DC Blocking Voltage | V _{DC} | 200 | 300 | 400 | 600 | V |
| Maximum Average Forward Output Current | I _{F(AV)} | 20 | | | | A |
| Peak Forward Surge Current (8.3ms single half sine-wave) | I _{FSM} | 100 | | | | A |

Thermal Characteristics

| Parameter | Symbol | Value | Unit |
|--|------------------|------------|------|
| Thermal Resistance (Junction-to-Ambient) ^{*1} | R _{θJA} | 12 | °C/W |
| Thermal Resistance (Junction-to-Case) ^{*1} | R _{θJC} | 7 | °C/W |
| Thermal Resistance (Junction-to-Lead) ^{*1} | R _{θJL} | 4 | °C/W |
| Operating Junction Temperature Range | T _J | -55 ~ +150 | °C |
| Storage Temperature Range | T _{STG} | -55 ~ +150 | °C |

Electrical Characteristics (@ $T_A = 25^\circ\text{C}$ unless otherwise specified)

| Symbol | Parameter | Test Condition | MUR20 20FC | MUR20 30FC | MUR20 40FC | MUR20 60FC | Unit |
|----------|---------------------------------|--|---------------|---------------|---------------|---------------|---------------|
| | | | Max. | | | | |
| V_F | Forward Voltage | $I_F = 10\text{A}$ | 0.98 | 1.3 | 1.3 | 1.5 | V |
| I_R | Maximum Peak Reverse Current | $V_R = V_{RRM}, T_A = 25^\circ\text{C}$ | 5 | 10 | 10 | 10 | μA |
| | | $V_R = V_{RRM}, T_A = 125^\circ\text{C}$ | 50 | 100 | 100 | 100 | μA |
| t_{rr} | Reverse Recovery Time | $I_F = 0.5\text{A}, I_{rr} = 0.25\text{A},$ $I_R = 1\text{A}$ | 25 | 50 | 50 | 50 | ns |

Note 1: The data tested by surface mounted on a 4.15cm * 5.4cm * 0.25cm aluminum heatsink

Ratings and Characteristics Curves (@ $T_A = 25^\circ\text{C}$ unless otherwise specified)

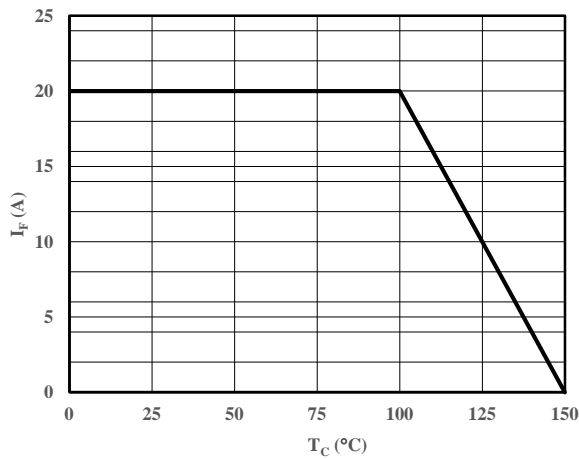

Fig 1 Current Derating Curve

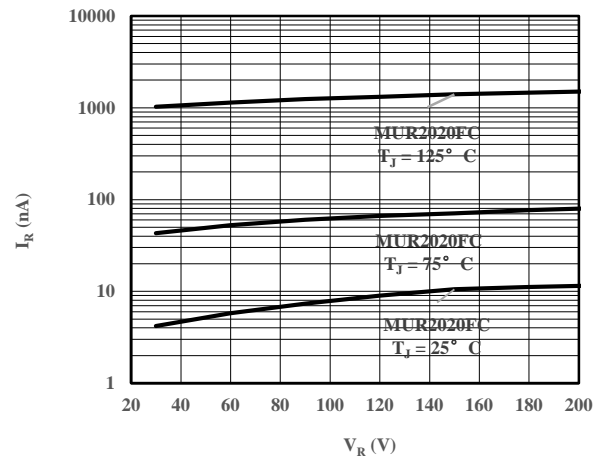

Fig 2 Typical Reverse Characteristic

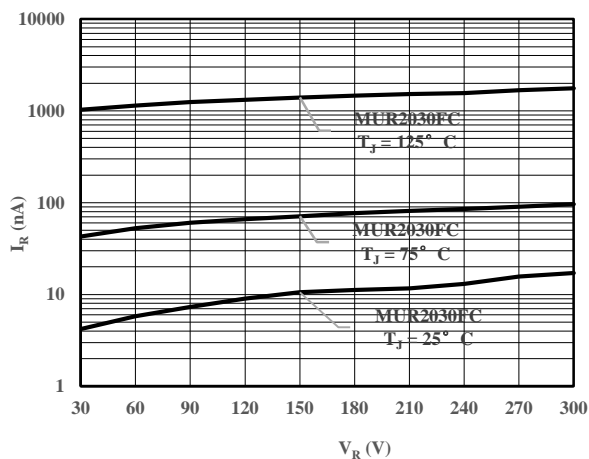

Fig 3 Typical Reverse Characteristic

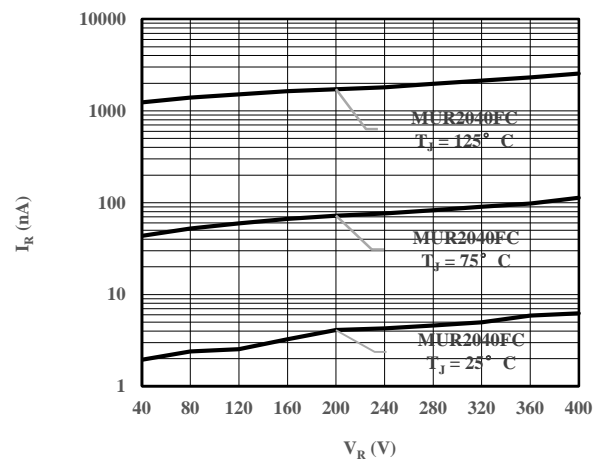

Fig 4 Typical Reverse Characteristic

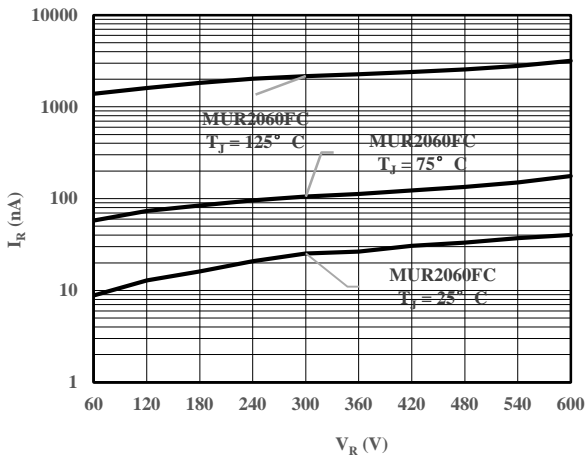

Fig 5 Typical Reverse Characteristic

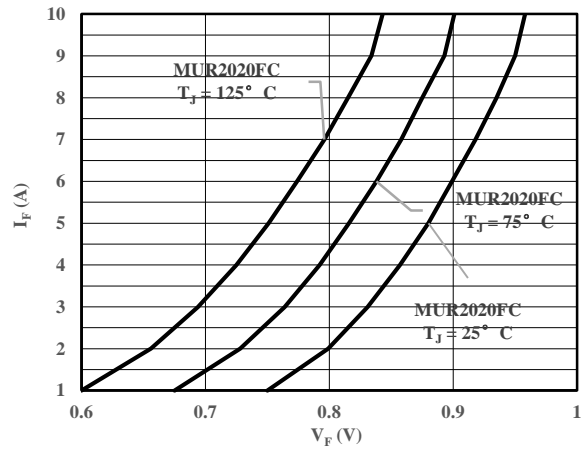

Fig 6 Typical Forward Characteristic

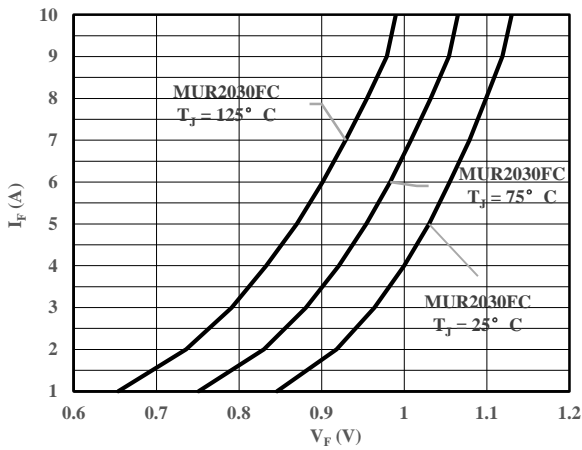

Fig 7 Typical Forward Characteristic

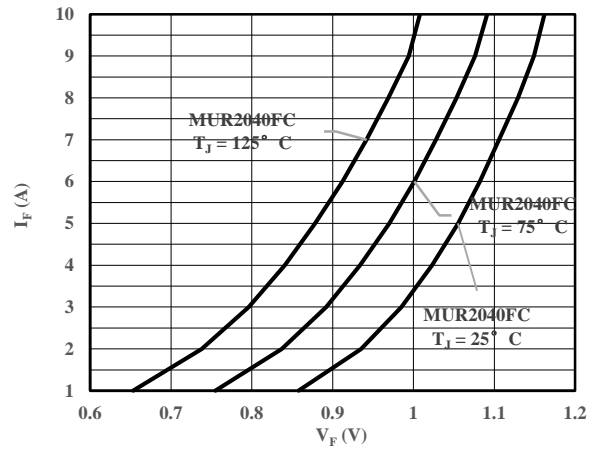

Fig 8 Typical Forward Characteristic

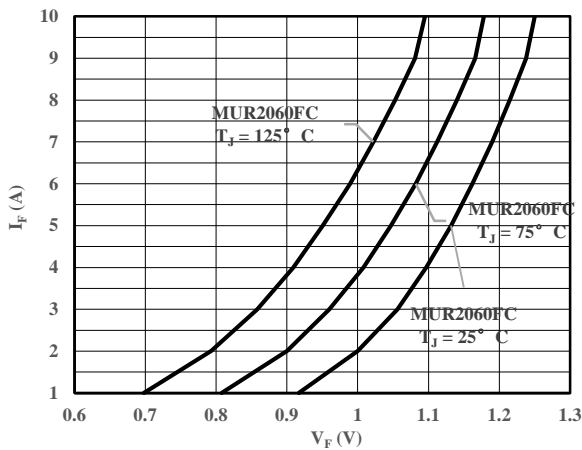
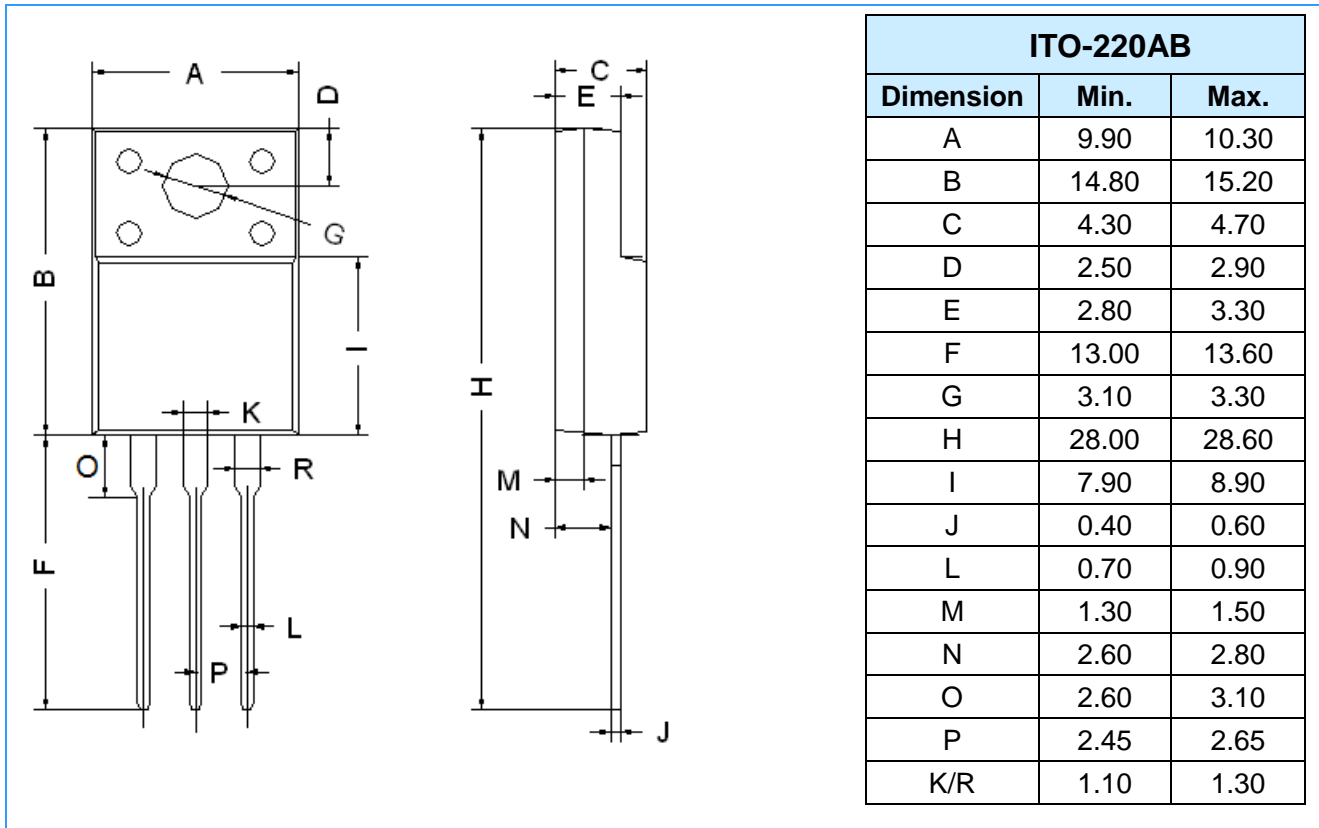

Fig 9 Typical Forward Characteristic

Package Outline Dimensions (Unit: mm)



Important Notice

Changzhou Galaxy Century Microelectronics (GME) reserves the right to make changes without further notice to any product information (copyrighted) herein to make corrections, modifications, improvements, or other changes. GME does not assume any liability arising out of the application or use of any product described herein; neither does it convey any license under its patent rights, nor the rights of others.