



S2ABF THRU S2MBF

SURFACE MOUNT GENERAL PURPOSE SILICON RECTIFIER

Reverse Voltage - 50 to 1000 Volts Forward Current - 2.0 Amperes

SMBF

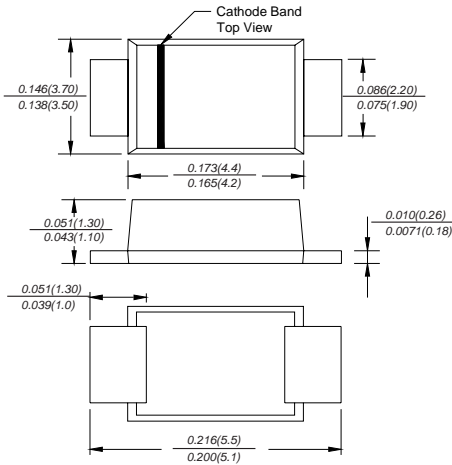

FEATURES

- ◆ For surface mounted applications
- ◆ Low profile package
- ◆ Glass Passivated Chip Junction
- ◆ Easy to pick and place
- ◆ Lead free in comply with EU RoHS 2011/65/EU directives

MECHANICAL DATA

Case: JEDEC SMBF molded plastic body
Terminals: leads solderable per MIL-STD-750, Method 2026
Mounting Position: Any
Weight: 57mg/0.002oz

MAXIMUM RATINGS AND ELECTRICAL CHARACTERISTICS

Ratings at 25°C ambient temperature unless otherwise specified.
 Single phase half-wave 60Hz, resistive or inductive load, for capacitive load current derate by 20%.

TWGMC Catalog Number	SYMBOLS	S2ABF	S2BBF	S2DBF	S2GBF	S2JBF	S2KBF	S2MBF	UNITS
Marking code		S2AB	S2BB	S2DB	S2GB	S2JB	S2KB	S2MB	
Maximum repetitive peak reverse voltage	V_{RRM}	50	100	200	400	600	800	1000	VOLTS
Maximum RMS voltage	V_{RMS}	35	70	140	280	420	560	700	VOLTS
Maximum DC blocking voltage	V_{DC}	50	100	200	400	600	800	1000	VOLTS
Maximum average forward rectified current at $T_L=65^\circ\text{C}$	$I_{(AV)}$	2.0							Amps
Peak forward surge current 8.3ms single half sine-wave superimposed on rated load (JEDEC Method)	I_{FSM}	60							Amps
Maximum instantaneous forward voltage at 2.0A	V_F	1.1							Volts
Maximum DC reverse current $T_A=25^\circ\text{C}$ at rated DC blocking voltage $T_A=125^\circ\text{C}$	I_R	5.0 100.0							μA
Typical junction capacitance (NOTE 1)	C_J	30							pF
Typical thermal resistance (NOTE 2)	$R_{\theta JA}$	55							$^\circ\text{C/W}$
Operating junction and storage temperature range	T_J, T_{STG}	-55 to +150							$^\circ\text{C}$

Note: 1. Measured at 1MHz and applied reverse voltage of 4.0V D.C.
 2. P.C.B. mounted with 0.5x0.5" (12.7x12.7mm) copper pad areas

RATINGS AND CHARACTERISTIC CURVES S2ABF THRU S2MBF

Fig.1 Forward Current Derating Curve

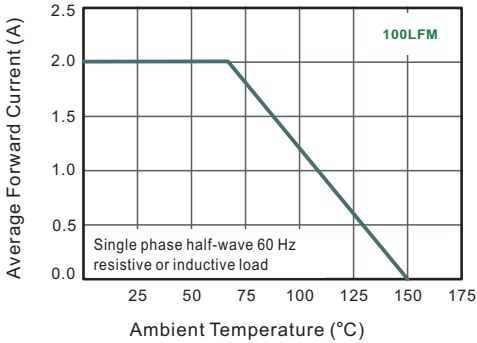

Fig.2 Typical Reverse Characteristics

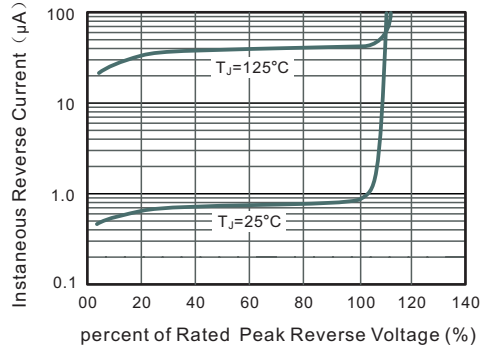

Fig.3 Typical Instantaneous Forward Characteristics

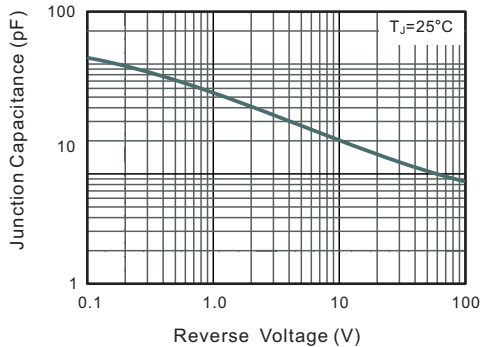
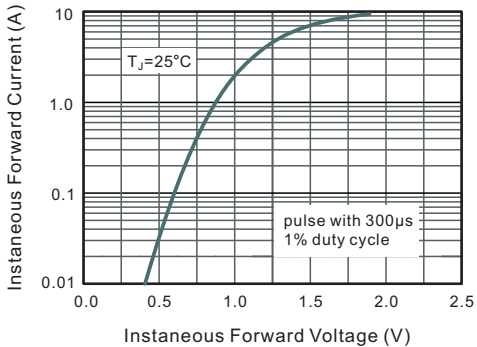
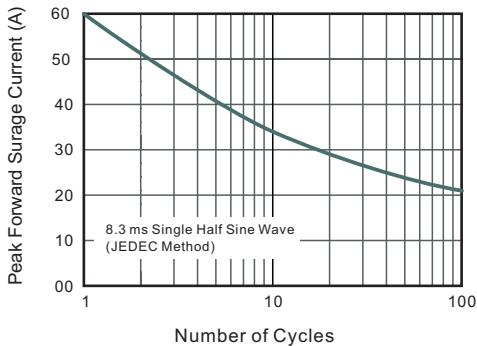

Fig.6 Maximum Non-Repetitive Peak Forward Surge Current



The cruve graph is for reference only, can't be the basis for judgment(曲线图仅供参考)!