

2.0A SINGLE-PHASE SILICON BRIDGE RECTIFIER - 50V~1000V

PRIMARY CHARACTERISTICS	
V_{RRM}	50V~1000V
$I_{(AV)}$	2.0A
V_F	1.1V
$T_{J,Max}$	125°C

SCHMATIC DIAGRAM
WOM PACKAGE

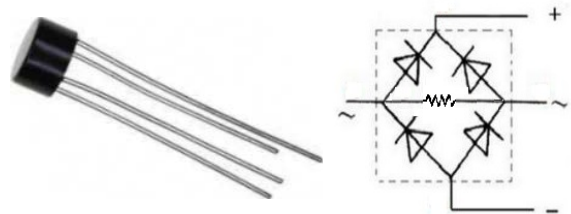

FEATURES

- Surge overload rating: 50 amperes peak
- Ideal for printed circuit board
- Reliable low cost construction utilizing molded plastic technique
- High temperature soldering guaranteed: 250°C/10 Sec
- Moisture Sensitivity Level 1

MECHANICAL DATA

- Case : Molded plastic,WOM
- Polarity : Shown above
- Terminals :Plated terminals, solderable per MIL-STD-750,Method 2026
- Epoxy : UL94-V0 rated flame retardant

Maximum Ratings and Electrical Characteristics

Ratings at 25°C ambient temperature unless otherwise specified. Single phase, half wave, 60Hz, resistive or inductive load.
For capacitive load, derate current by 20%.

	Symbols	2W005M	2W01M	2W02M	2W04M	2W06M	2W08M	2W10M	Unit
Maximum Recurrent Peak Reverse Voltage	V_{RRM}	50	100	200	400	600	800	1000	Volts
Maximum RMS Voltage	V_{RMS}	35	70	140	280	420	560	700	Volts
Maximum DC Blocking Voltage	V_{DC}	50	100	200	400	600	800	1000	Volts
Maximum Average Forward Rectified Current .375"(9.5mm) Lead Length at $T_A=50^\circ C$	$I_{(AV)}$	2.0							Amp
Peak Forward Surge Current, 8.3ms single half-sine-wave superimposed on rated load (JEDEC method)	I_{FSM}	50							Amp
Maximum Forward Voltage at 2.0A DC and 25°C	V_F	1.1							Volts
Maximum Reverse Current at Rated DC at $T_A=25^\circ C$ Blocking Voltage $T_A=100^\circ C$	I_R	5.0 500							uAmp
Typical Junction Capacitance (Note 1)	C_J	40				20			pF
Typical Thermal Resistance (Note 2)	$R_{\theta JA}$	40							°C/W
Typical Thermal Resistance (Note 2)	$R_{\theta JL}$	15							°C/W
Operating and Storage Temperature Range	T_J, T_{stg}	-55 to +125							°C

NOTES:

- 1- Measured at 1 MHz and applied reverse voltage of 4.0 VDC.
- 2- Thermal Resistance Junction to Ambient and form junction to lead at 0.375"(9.5mm) lead length P.C.B. Mounted.

RATINGS AND CHARACTERISTIC CURVES

FIG.1- MAXIMUM NON-REPETITIVE FORWARD SURGE CURRENT PER BRIDGE ELEMENT

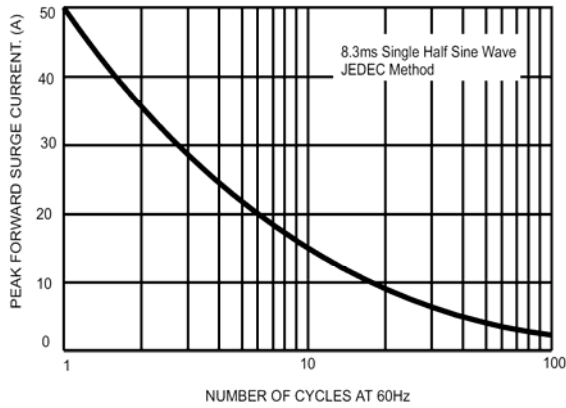

FIG.2- MAXIMUM CURRENT DERATING CURVE OUTPUT RECTIFIED CURRENT

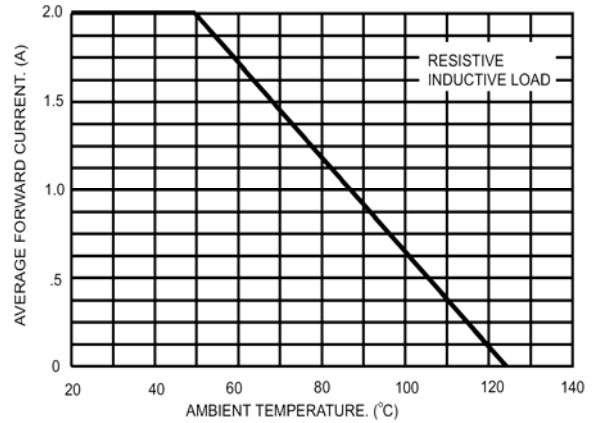

FIG.3- TYPICAL INSTANTANEOUS FORWARD CHARACTERISTICS PER BRIDGE ELEMENT

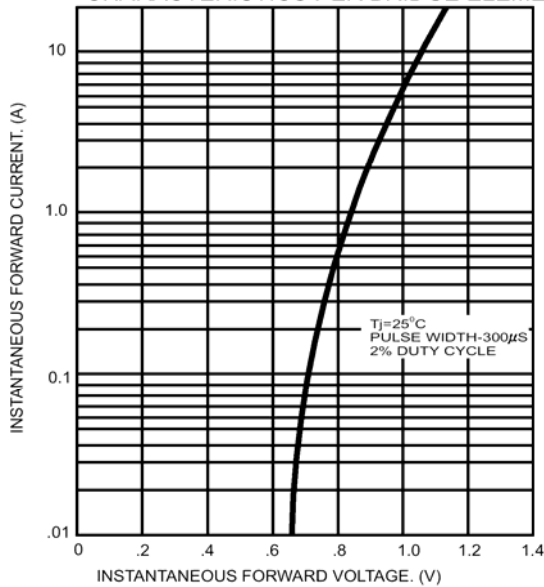
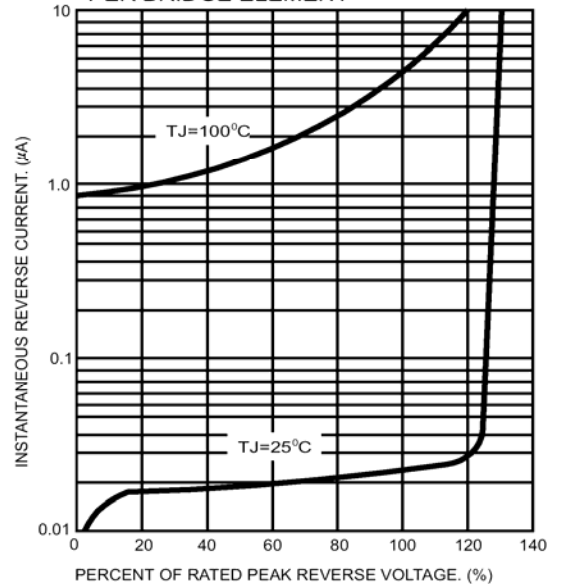
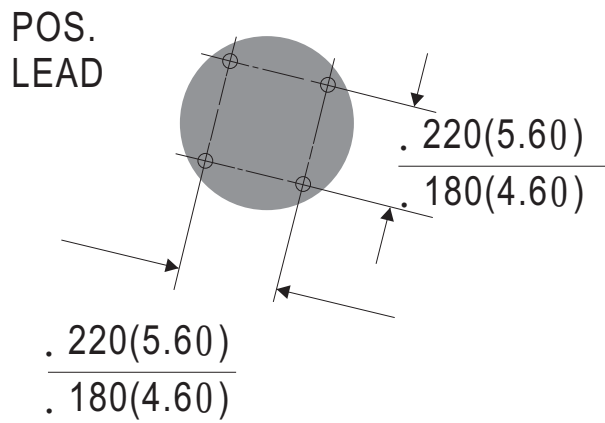
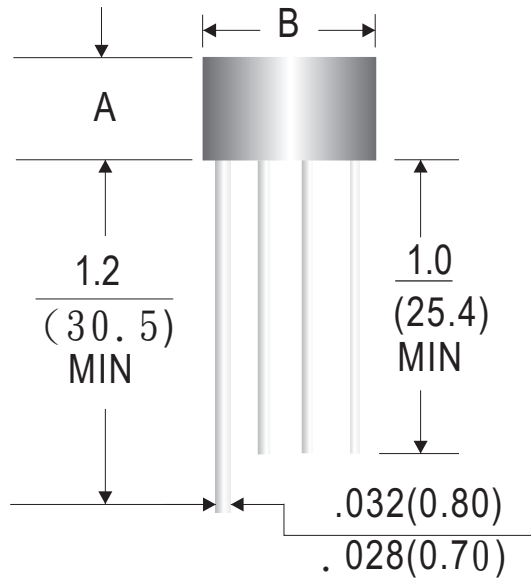

FIG.4- TYPICAL REVERSE CHARACTERISTICS PER BRIDGE ELEMENT



Outline Drawing

WOM



A	B
$\frac{.217(5.50)}{.197(5.00)}$	$\frac{.360(9.10)}{.340(8.60)}$

Dimensions in inches and (millimeters)

Rev.C

Ordering Information:

Device PN	Packing
Part Number-B ⁽¹⁾ G ⁽²⁾ WS ⁽³⁾	Bulk Packing:500pcs/Bag

Note: (1) Packing code: B is Bulk Packing

(2) RoHS product for packing code suffix "G" ; Halogen free product for packing code suffix "H"

(3) WS : Willas brand abbreviation, Label Type does not display

*****Disclaimer*****

WILLAS reserves the right to make changes without notice to any product specification herein, to make corrections, modifications, enhancements or other changes. WILLAS or anyone on its behalf assumes no responsibility or liability for any errors or inaccuracies. Data sheet specifications and its information contained are intended to provide a product description only. "Typical" parameters which may be included on WILLAS data sheets and/ or specifications can and do vary in different applications and actual performance may vary over time. WILLAS does not assume any liability arising out of the application or use of any product or circuit.

This is the preliminary specification. WILLAS products are not designed, intended or authorized for use in medical, life-saving implant or other applications intended for life-sustaining or other related applications where a failure or malfunction of component or circuitry may directly or indirectly cause injury or threaten a life without expressed written approval of WILLAS. Customers using or selling WILLAS components for use in such applications do so at their own risk and shall agree to fully indemnify WILLAS Inc and its subsidiaries harmless against all claims, damages and expenditures.