

Aug.1.2022 Copyright 2022 HIROSE ELECTRIC CO., LTD. All Rights Reserved.
In case of consideration for using Automotive equipment / device which demand high reliability, kindly contact our sales window correspondents.

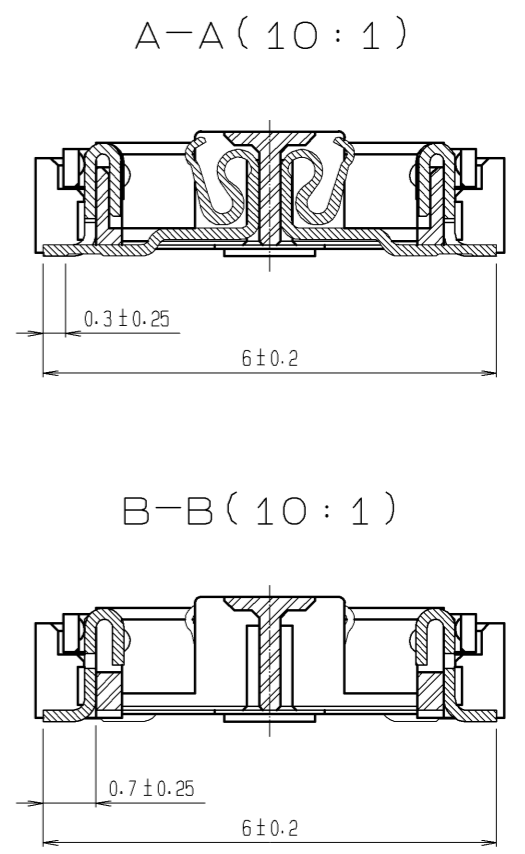

RECOMMENDED LAND PATTERN DIMENSION OF PCB
(RECOMMENDED METAL MASK THICKNESS: 0.15mm)

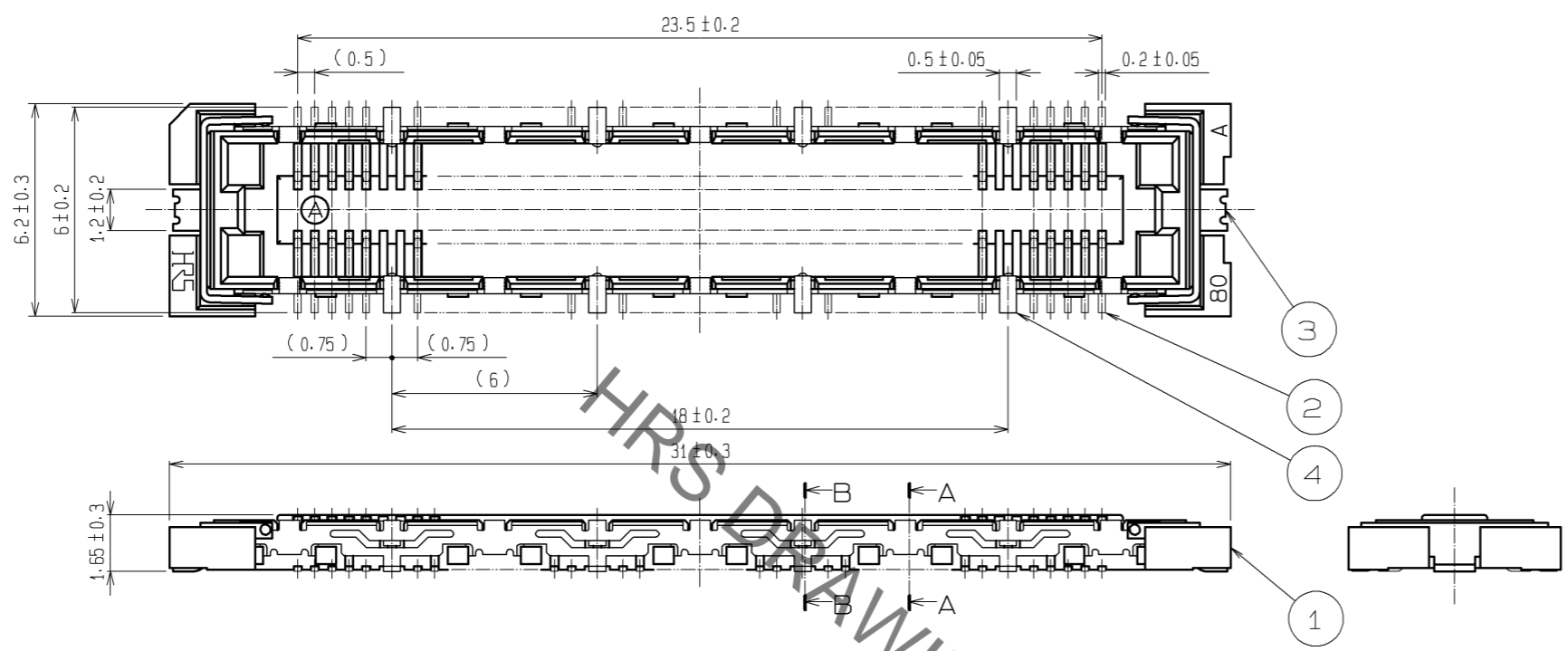
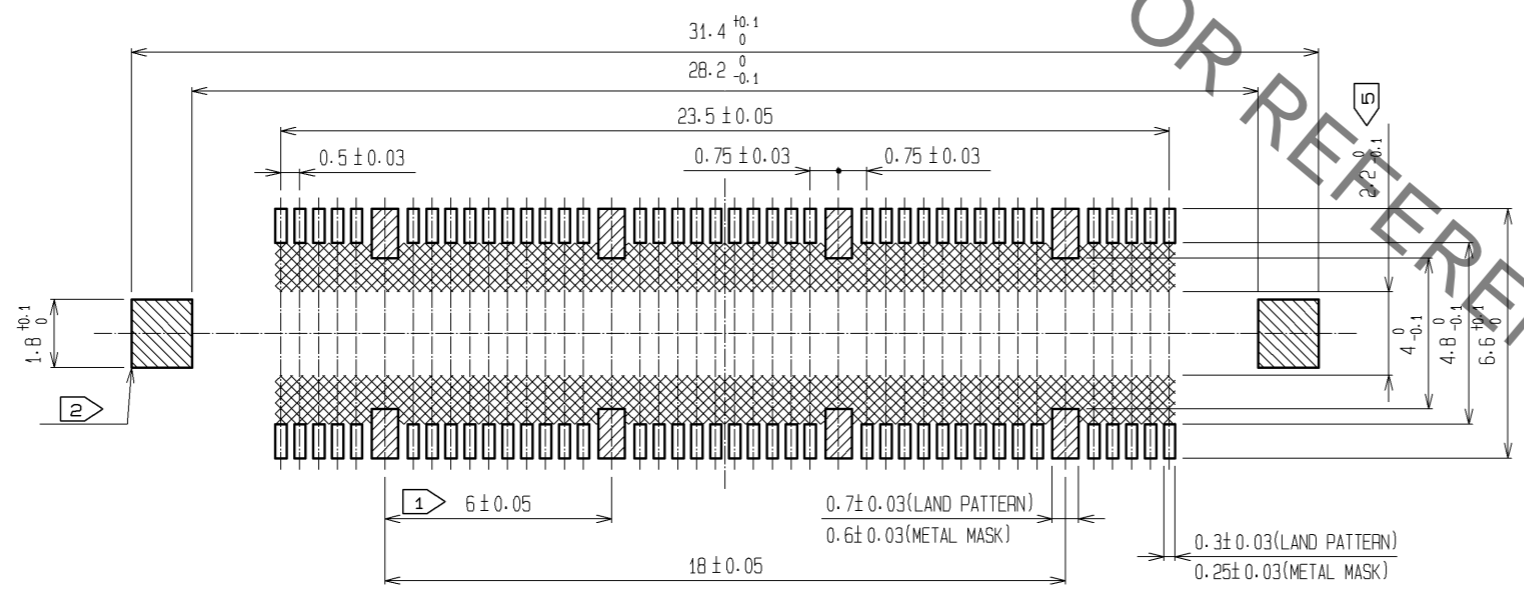

- NOTES
- ① 8 HATCHED PARTS: GROUND CIRCUIT.
 - ② 2 HATCHED PARTS: GROUND CIRCUIT.
 - ③ SMT LEAD-COPLANARITY: 0.1 MAX.
 - ④ THIS PRODUCT HAS NO POLARITY TO PATTERN FOR MOUNTING.
 - ⑤ MAKE SURE WIDTH OF PATTERN IS WITHIN THAT OF LAND .OR LEAD MAY TOUCH PATTERN. (THIS APPLIES TO HATCHED AREA.)
 - ⑥ THE DIMENSIONS IN PARENTHESES ARE FOR REFERENCE.

1	LCP	BEIGE	UL94V-0	3, 4	PHOSPHOR BRONZE	TIN PLATING		
2				2	PHOSPHOR BRONZE	CONTACT AREA : GOLD 0.1μm min. LEAD AREA : GOLD 0.05μm min. UNDER PLATING : NICKEL 1μm min.		
NO.	MATERIAL	FINISH	REMARKS	NO.	MATERIAL	FINISH . REMARKS		
UNITS	mm	SCALE	5 : 1	COUNT	DESCRIPTION OF REVISIONS	DESIGNED	CHECKED	DATE
		APPROVED : HS. OKAWA 09.10.19 CHECED : HT. YAMAGUCHI 09.10.19 DESIGNED : SY. KAMIGA 09.10.17 DRAWN : HK. SUNADORI 09.10.16		DRAWING NO. EDC3-152113-25 PART NO. FX11LB-80S/8-SV(71) CODE NO. CL573-0113-8-71		1/1		