







600 W Surface Mount Transient Voltage Suppressor

<p>DO-214AA (SMB)</p> 	<p>Voltage 6.8 V to 220 V</p>	<p>Power 600 W /ms</p>	
			
	<p>FEATURES</p> <ul style="list-style-type: none"> • Low profile package • Ideal for automated placement • 600 W peak pulse power capability with a 10/1000 μs waveform, repetitive rate (duty cycle): 0.01 % • Excellent clamping capability • Low inductance • Available in uni-directional and bi-directional • Solder dip 260°C, 10s • AEC-Q101 qualified • Component in accordance to RoHS 2011/65/EU and WEEE 2002/96/EC • Meets MSL level 1, per J-STD-020, LF maximum peak of 260° C 		   RoHS COMPLIANT 
	<p>MECHANICAL DATA</p> <ul style="list-style-type: none"> • Case: DO-214AA (SMB). Epoxy meets UL 94V-0 flammability rating. • Polarity: For unidirectional types color band denotes cathode end. No marking on bidirectional types. • Terminals: Matte tin plated leads, solderable per MIL-STD-750 Method 2026, J-STD-002 and JESD22-B102. Consumer grade, meets JESD 201 class 1A whisker test. • HE3 suffix for high reliability grade, meets JESD 201 class 2 whisker test. 		
<p>TYPICAL APPLICATIONS</p> <p>Used in sensitive electronics protection against voltage transients induced by inductive load switching and lighting on ICs, MOSFET, signal lines of sensor units for consumer, computer, industrial, automotive and telecommunication.</p>			

Maximun Ratings and Electrical Characteristics at 25°C

P_{PPM}	Peak Pulse Power Dissipation with 10/1000 μ s exponential pulse		600 W
I_{FSM}	Peak Forward Surge Current 8.3 ms. (Jedec Method)	(Note 1) (Note 2)	100 A
V_F	Max. forward voltage drop at $I_F = 50$ A	(Note 1)	3.5 V
T_j	Operating temperature range	$V_{BR} \leq 43$ V	- 65 to + 175 °C
		$V_{BR} > 43$ V	- 65 to + 150 °C
T_{stg}	Storage temperature range		- 65 to + 175 °C
$R_{th(j-a)}$	Typical Thermal Resistance junction to ambient	(Note 3)	200 °C/W
		(Note 4)	100 °C/W
$R_{th(j-l)}$	Typical Thermal Resistance junction to lead		20 °C/W

Notes: 1. Only for Unidirectional

2. Mounted on 0.31 x 0.31" (8.0 x 8.0 mm) copper pads to each terminal

3. Device mounted on an FR4 PCB, standard footprint

 4. Device mounted on an Al₂O₃ PCB, standard footprint

600 W Surface Mount Transient Voltage Suppressor

Ordering information

PREFERRED P/N	PACKAGE CODE	DELIVERY MODE	BASE QUANTITY	UNIT WEIGHT (g)
SM6T33A TRTB	TRTB	13" diameter tape and reel	3,200	0.082
SM6T33A TRTS	TRTS	7" diameter tape and reel	750	0.082
SM6T33A HE3 TRTB	TRTB	13" diameter tape and reel	3,200	0.082
SM6T33A HE3 TRTS	TRTS	7" diameter tape and reel	750	0.082
SM6T33A HF TRTB	TRTB	13" diameter tape and reel	3,200	0.082
SM6T33CA TRTB	TRTB	13" diameter tape and reel	3,200	0.082
SM6T33CA TRTS	TRTS	7" diameter tape and reel	750	0.082
SM6T33CA HE3 TRTB	TRTB	13" diameter tape and reel	3,200	0.082
SM6T33CA HE3 TRTS	TRTS	7" diameter tape and reel	750	0.082
SM6T33CA HF TRTB	TRTB	13" diameter tape and reel	3,200	0.082

Package Outline Dimensions: (mm) DO-214AA (SMB)

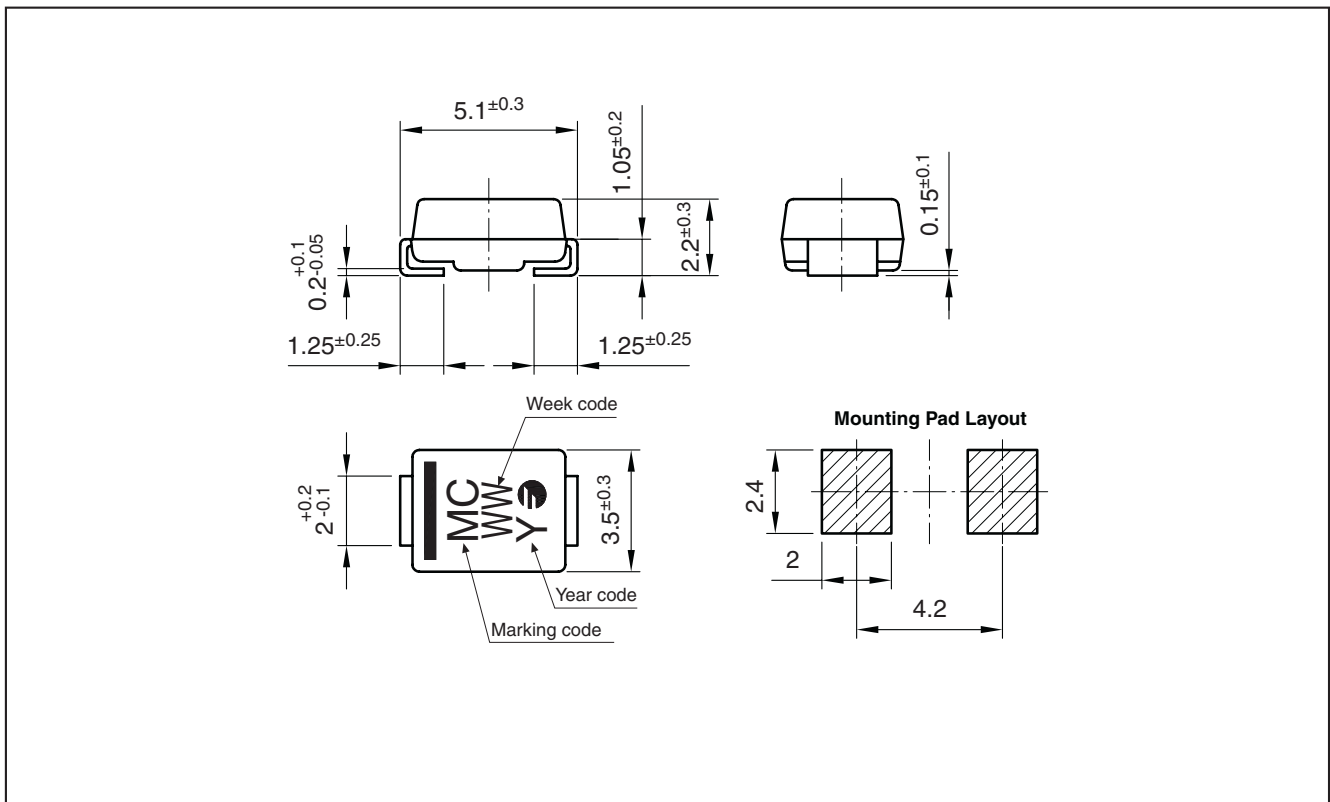

600 W Surface Mount Transient Voltage Suppressor

Types				Maximum Reverse Leakage Current		Breakdown Voltage ⁽¹⁾				Max. Clamping Voltage V_{CL} at I_{pp} 1ms. Expo.	
Unidirectional	Mark	Bidirectional	Mark	I_{RM} (μA)	at V_{RM} (V)	V_{BR} (V)			I_R (mA)	(V)	(A)
						Min.	Nom.	Max.			
SM6T6V8A	7A	SM6T6V8CA	8A	1000	5.8	6.45	6.8	7.14	10	10.5	57
SM6T7V5A	7B	SM6T7V5CA	8B	500	6.4	7.13	7.5	7.88	10	11.3	53
SM6T10A	7C	SM6T10CA	8C	10	8.55	9.50	10	10.5	1	14.5	41
SM6T12A	7D	SM6T12CA	8D	5	10.2	11.4	12	12.6	1	16.7	36
SM6T15A	7E	SM6T15CA	8E	1	12.8	14.3	15	15.8	1	21.2	28
SM6T18A	7F	SM6T18CA	8F	1	15.3	17.1	18	18.9	1	25.5	24
SM6T22A	7G	SM6T22CA	8G	1	18.8	20.9	22	23.1	1	30.6	20
SM6T24A	7H	SM6T24CA	8H	1	20.5	22.8	24	25.2	1	33.2	18
SM6T27A	7I	SM6T27CA	8I	1	23.1	25.7	27	28.4	1	37.5	16
SM6T30A	7J	SM6T30CA	8J	1	25.6	28.5	30	31.5	1	41.4	14.4
SM6T33A	7K	SM6T33CA	8K	1	28.8	31.4	33	34.7	1	45.7	13.2
SM6T36A	7L	SM6T36CA	8L	1	30.8	34.4	36	37.8	1	49.9	12
SM6T39A	7M	SM6T39CA	8M	1	33.3	37.1	39	41	1	53.9	11.2
SM6T68A	7N	SM6T68CA	8N	1	58.1	64.6	68	71.4	1	92	6.5
SM6T100A	7O	SM6T100CA	8O	1	85.5	95	100	105	1	137	4.4
SM6T150A	7P	SM6T150CA	8P	1	128	143	150	158	1	207	2.9
SM6T200A	7Q	SM6T200CA	8Q	1	171	190	200	210	1	274	2.2
SM6T220A	7R	SM6T220CA	8R	1	185	209	220	231	1	328	1.83

(1) Tested with pulses.
Pulse test: $t_p \leq 50$ ms; $\delta < 2\%$

600 W Surface Mount Transient Voltage Suppressor

Ratings and Characteristics (Ta 25 °C unless otherwise noted)

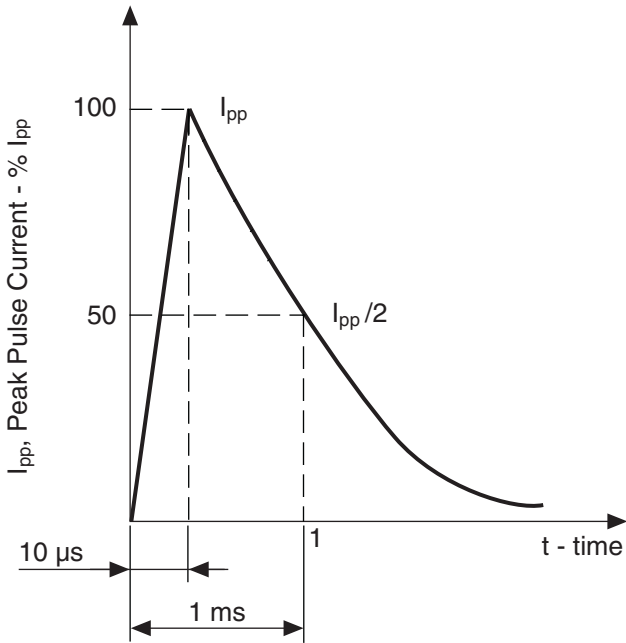

Pulse wave form 10/1000

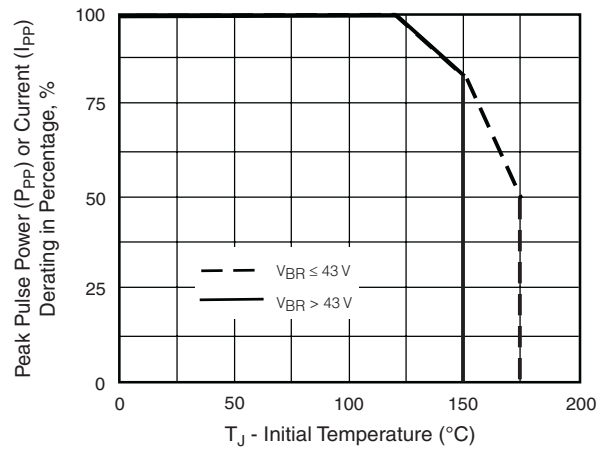

Pulse Power or Current vs. Initial Junction Temperature

PEAK PULSE POWER RATING CURVE

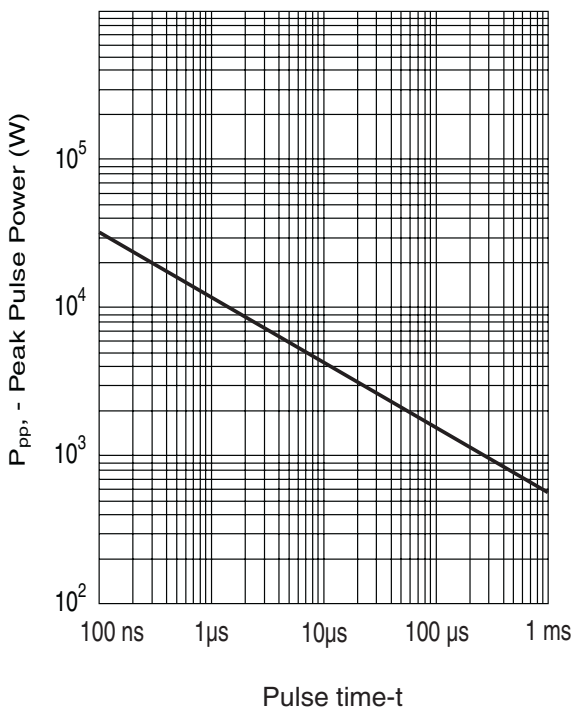

TYPICAL JUNCTION CAPACITANCE

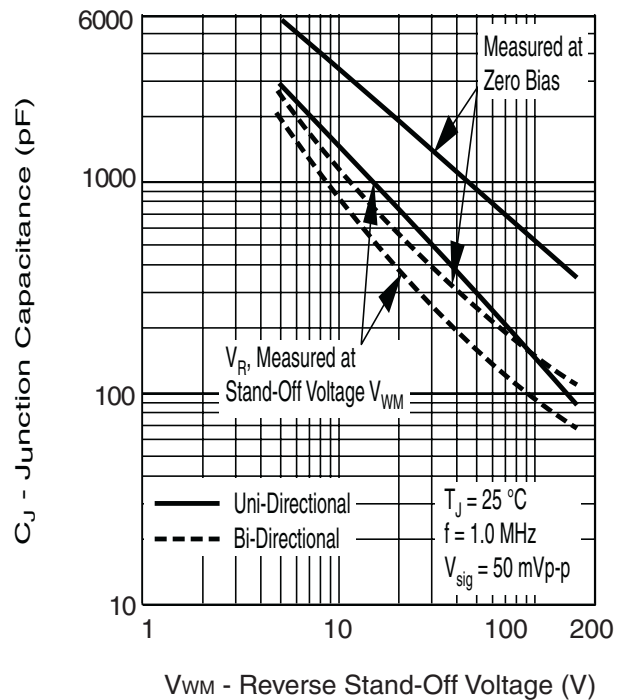

600 W Surface Mount Transient Voltage Suppressor**Revision History**

Date	Revision	Description of Changes
19-Dec-2013	0	Original Data Sheet
12-May-2014	1	Update Peak Pulse Power Derating Curve.
18-Nov-2016	2	Include Rthjl and Rthja parameters
02-Dec-2016	3	Include Rthja parameter

Disclaimer

All product, product specifications and data are subject to change without notice to improve reliability, function or design or otherwise.

Fagor Electrónica, S.Coop., its affiliates, agents, and employees, and all persons acting on its or their behalf (collectively, "Fagor"), disclaim any and all liability for any errors, inaccuracies or incompleteness contained in any datasheet or in any other disclosure relating to any product.

Fagor makes no warranty, representation or guarantee regarding the suitability of the products for any particular purpose or the continuing production of any product. To the maximum extent permitted by applicable law, Fagor disclaims (i) any and all liability arising out of the application or use of any product, (ii) any and all liability, including without limitation special, consequential or incidental damages, and (iii) any and all implied warranties, including warranties of fitness for particular purpose, non-infringement and merchantability.

Statements regarding the suitability of products for certain types of applications are based on Fagor's knowledge of typical requirements that are often placed on Fagor products in generic applications. Such statements are not binding statements about the suitability of products for a particular application. It is the customer's responsibility to validate that a particular product with the properties described in the product specification is suitable for use in a particular application. Parameters provided in datasheets and/or specifications may vary in different applications and performance may vary over time. All operating parameters, including typical parameters, must be validated for each customer application by the customer's technical experts. Product specifications do not expand or otherwise modify Fagor's terms and conditions of purchase, including but not limited to the warranty expressed therein.

Except as expressly indicated in writing, Fagor products are not designed for use in medical, life-saving, or life-sustaining applications or for any other application in which the failure of the Fagor product could result in personal injury or death. Customers using or selling Fagor products not expressly indicated for use in such applications do so at their own risk and agree to fully indemnify and hold Fagor and its distributors harmless from and against any and all claims, liabilities, expenses and damages arising or resulting in connection with such use or sale, including attorneys fees, even if such claim alleges that Fagor or its distributor was negligent regarding the design or manufacture of the part. Please contact authorized Fagor personnel to obtain written terms and conditions regarding products designed for such applications.

No license, express or implied, by estoppel or otherwise, to any intellectual property rights is granted by this document or by any conduct of Fagor, Product names and markings noted herein may be trademarks of their respective owners.