

Ultra-Fast Recovery Rectifier

US3GBF

Features

- Low forward voltage drop
- High forward surge current capability
- Low-profile SMD ideal for automated manufacturing
- RoHS compliant with Halogen-free

HF



Mechanical Data

- Case: SMBF molded plastic
- Molding compound: UL flammability classification rating 94V-0
- Terminals: Solder plated; solderable per MIL- STD-202, Method 208
- Polarity: Color band denotes cathode end

Maximum Ratings (@ T_A = 25°C unless otherwise specified)

Parameter	Symbol	US3GBF	Unit
Peak Repetitive Reverse Voltage	V _{RRM}	400	V
RMS Reverse Voltage	V _{RMS}	280	V
DC Blocking Voltage	V _{DC}	400	V
Maximum Average Forward Output Current	I _{F_AV}	3.0	A
Peak Forward Surge Current, 8.3ms Single Half Sine wave	I _{FSM}	100	A

Thermal Characteristics

Parameter	Symbol	US3GBF	Unit
Typical Thermal Resistance *1	R _{θJA}	65	°C/W
	R _{θJC}	16	
	R _{θJL}	15	
Operating Junction Temperature Range	T _J	-55 ~ +150	°C
Storage Temperature Range	T _{STG}	-55 ~ +150	°C

Note *1: Device mounted on p.c.b. with 10 mm x 20 mm x 0.1mm copper pad area

Ultra-Fast Recovery Rectifier

US3GBF

Electrical Characteristics (@ $T_A = 25^\circ\text{C}$ unless otherwise specified)

Parameter	Symbol	Test Condition	Typ.	Max.	Unit	
Maximum Instantaneous Forward Voltage	V_F	$I_F = 3.0\text{A}$	-	1.25	V	
Maximum Reverse Current	I_R	Rated	@ $T_A = 25^\circ\text{C}$	-	10	μA
		V_R	@ $T_A = 125^\circ\text{C}$	-	500	
Maximum Reverse Recovery Time	t_{rr}	$I_F = 0.5\text{A}$, $I_{RM} = 1\text{A}$, $I_{R(REC)} = 0.25\text{A}$	-	50	ns	

Ultra-Fast Recovery Rectifier

US3GBF

Ratings and Characteristic Curves (@ $T_A=25^\circ\text{C}$ unless otherwise noted)

Fig.1 Forward Current Derating Curve

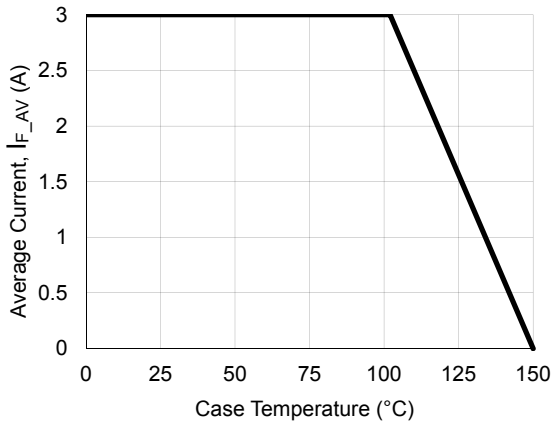

Fig.2 Surge Current Derating Curve

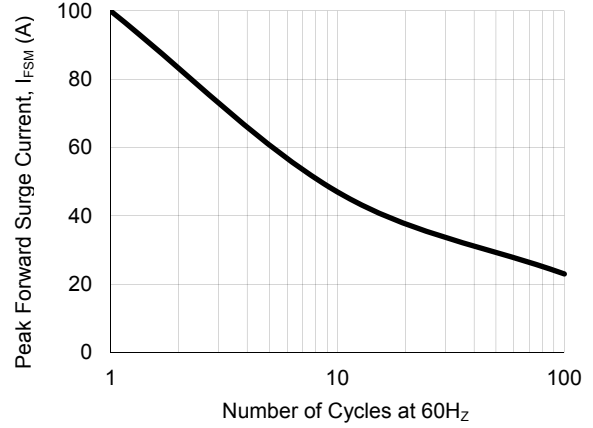

Fig.3 Typical Forward Voltage Characteristics

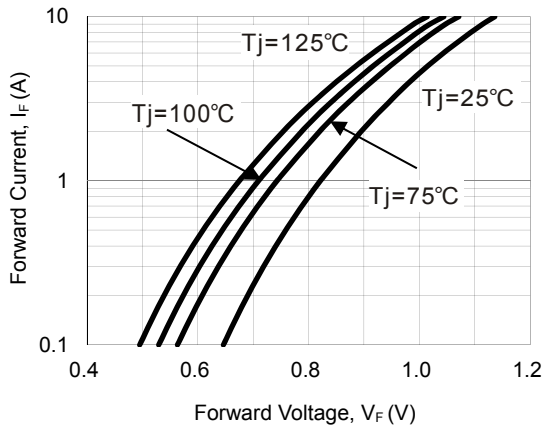
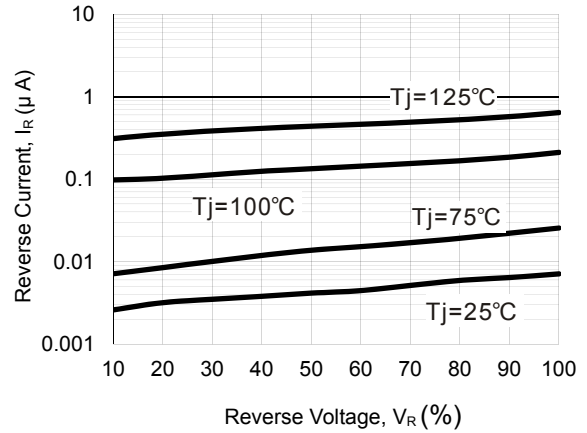

Fig.4 Typical Reverse Characteristics



Ultra-Fast Recovery Rectifier

US3GBF

Package Outline Dimensions (Unit: mm)

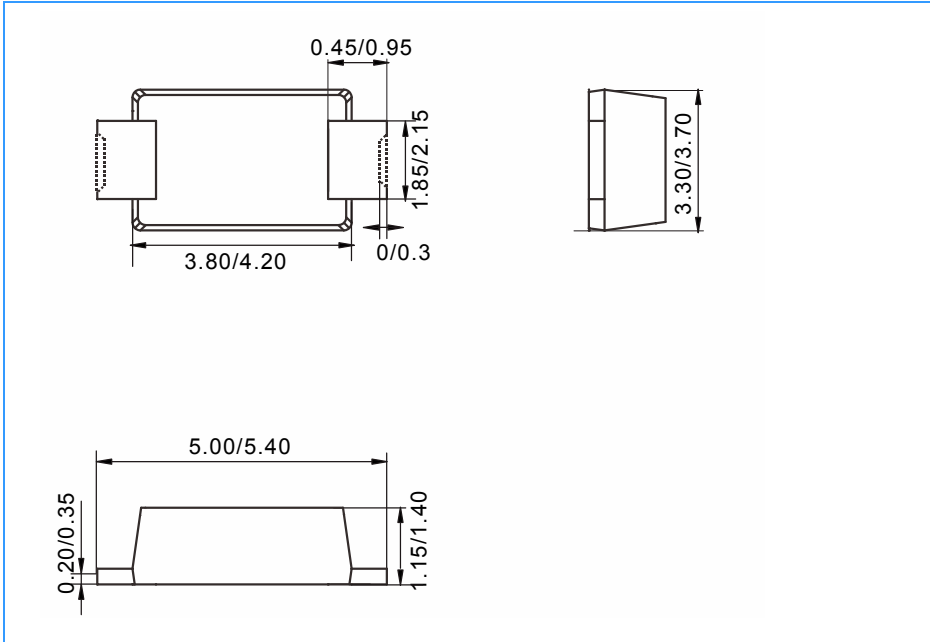

Mounting Pad Layout (Unit: mm)

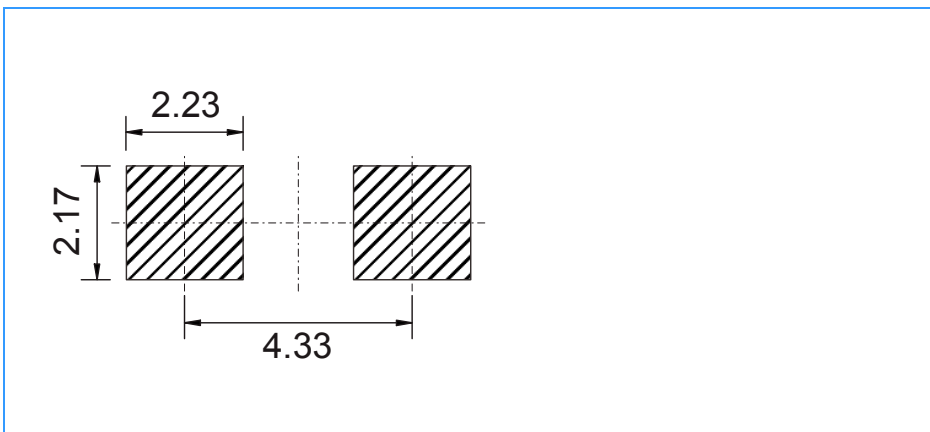

Ordering Information

Part Number	Marking	Package	Shipping Quantity
US3GBF	US3GBF	SMBF	4000 / Tape & Reel