



SS32BF THRU SS320BF

SURFACE MOUNT SCHOTTKY BARRIER RECTIFIER

Reverse Voltage - 20 to 200 Volts Forward Current - 3.0 Ampere

SMBF

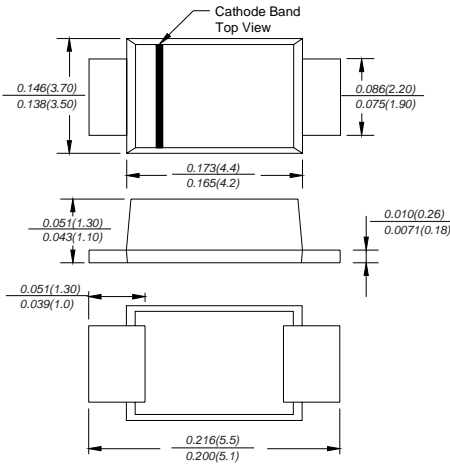

FEATURES

- ◆ Metal silicon junction, majority carrier conduction
- ◆ For surface mounted applications
- ◆ Low power loss, high efficiency
- ◆ High forward surge current capability
- ◆ For use in low voltage, high frequency inverters, free-wheeling, and polarity protection applications

MECHANICAL DATA

Case: JEDEC SMBF molded plastic body
Terminals: leads solderable per MIL-STD-750, Method 2026
Mounting Position: Any
Weight: 57mg/0.002oz

MAXIMUM RATINGS AND ELECTRICAL CHARACTERISTICS

Ratings at 25°C ambient temperature unless otherwise specified.
 Single phase half-wave 60Hz, resistive or inductive load, for capacitive load current derate by 20%.

TWGMC Catalog Number	SYMBOLS	SS32BF	SS34BF	SS36BF	SS38BF	SS310BF	SS315BF	SS320BF	UNITS
Marking code		S32B	S34B	S36B	S38F	S310B	S315B	S320B	
Maximum repetitive peak reverse voltage	V_{RRM}	20	40	60	80	100	150	200	VOLTS
Maximum RMS voltage	V_{RMS}	14	28	42	56	70	105	140	VOLTS
Maximum DC blocking voltage	V_{DC}	20	40	60	80	100	150	200	VOLTS
Maximum average forward rectified current at T_L (see fig.1)	$I_{(AV)}$	3.0							Amp
Peak forward surge current 8.3ms single half sine-wave superimposed on rated load (JEDEC Method)	I_{FSM}	80.0			70.0				Amps
Maximum instantaneous forward voltage at 3.0A	V_F	0.55	0.70	0.85		0.95		Volts	
Maximum DC reverse current at rated DC blocking voltage	I_R	0.5 5.0			0.3 3.0		mA		
Typical junction capacitance (NOTE 1)	C_J	450			400				pF
Typical thermal resistance (NOTE 2)	$R_{\theta JA}$	50.0							°C/W
Operating junction temperature range	T_J	-50 to +125							°C
Storage temperature range	T_{STG}	-50 to +150							°C

Note: 1. Measured at 1MHz and applied reverse voltage of 4.0V D.C.
 2. P.C.B. mounted with 0.2x0.2" (5.0x5.0mm) copper pad areas

RATINGS AND CHARACTERISTIC CURVES SS32BF THRU SS320BF

Fig.1 Forward Current Derating Curve

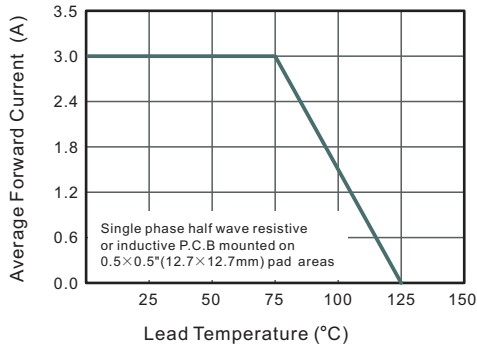

Fig.2 Typical Reverse Characteristics

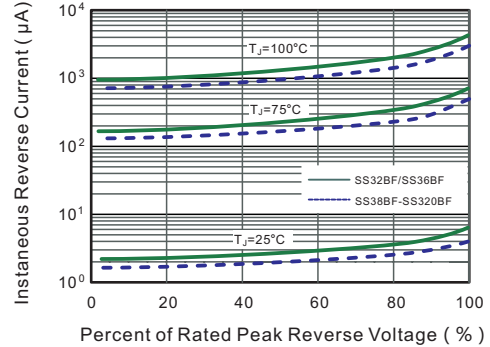

Fig.3 Typical Forward Characteristic

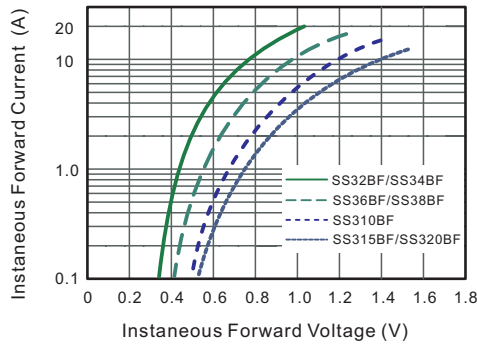

Fig.4 Typical Junction Capacitance

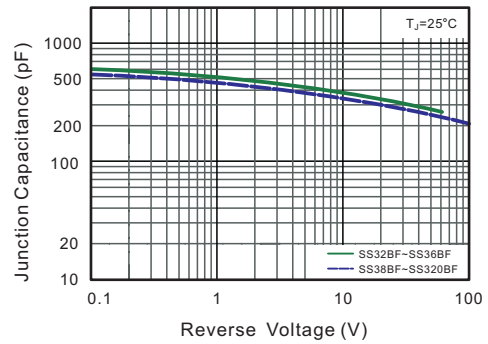

Fig.5 Maximum Non-Repetitive Peak Forward Surge Current

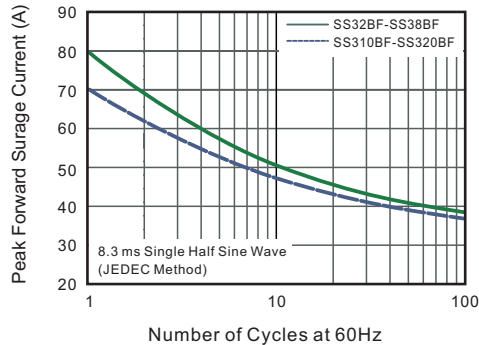

Fig.6- Typical Transient Thermal Impedance

