

Motor Driver IC Family

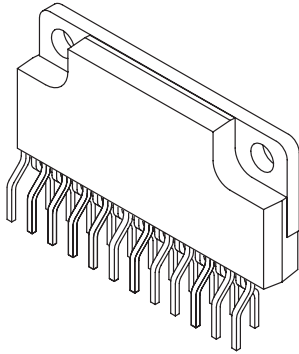

ABSOLUTE MAXIMUM RATINGS

AT $T_A = 25^\circ\text{C}$

Load (Motor) Supply Voltage, V_M	46 V
Main Power Supply Voltage, V_{BB}	46 V
Logic Supply Voltage, V_{DD}	7 V
Output Current, I_{OUT}	
SLA7075M	1.0 A
SLA7076M	1.5 A
SLA7077M	2.0 A
SLA7078M	3.0 A
Logic Input Voltage, V_{IN}	
.....	-0.3 to $V_{DD}+0.3$ V
REF Input Voltage, V_{REF}	
.....	-0.3 to $V_{DD}+0.3$ V
Sense Voltage, V_{SInt}	
$t_w < 1 \mu\text{s}$ is not considered	± 2 V
Power Dissipation, P_D	
Without heat sink	4.7 W
Junction Temperature, T_J	150°C
Ambient Temperature, T_A	-20 to 85°C
Storage Temperature, T_{Stg} ...	-30 to 150°C

The SLA7075M, SLA7076M, SLA7077M, and SLA7078M motor driver ICs feature 2-phase stepper unipolar drivers. The clock-in type input interface allows simplified control logic, and options for built-in sense current detection and load circuit short or open protection (patent pending) provide lower loss, and lower thermal resistance. All products in the SLA7070M series are pin-compatible, supporting rapid design of application variants.

The built-in excitation distribution circuit (sequencer) allows motor control using only the CLOCK signal for simple operations (rotate/stop), with motor speed control by frequency input into CLOCK pin. This eliminates logic signal lines required for conventional phase-input methods, and reduces demand on heavily-used CPUs.

Contact Allegro® for application information and additional information on device performance and logic.

FEATURES AND BENEFITS

Features

- Power supply voltages, V_{BB} : 46 V(max.), 10 to 44 V normal operating range
- Logic supply voltages, V_{DD} : 3.0 to 5.5 V
- Maximum output currents: 1 A, 1.5 A, 2 A, 3 A
- Built-in sequencer
- Simplified clock-in stepping control
- Microstepping at full-, half-, quarter-, eighth-, and sixteenth-steps
- Built-in sense resistor, R_{SInt}
- All variants are pin-compatible for enhanced design flexibility
- ZIP type 23-pin molded package (SLA package)
- Self-excitation PWM current control with fixed off-time; off-time adjusted automatically by step reference current ratio (3 levels)
- Built-in synchronous rectifying circuit reduces losses at PWM off
- Synchronous PWM chopping function prevents motor noise in Hold mode
- Sleep mode for reducing the IC input current in stand-by state
- Built-in protection circuitry against motor coil opens/shorts option available

***SLA7075M, SLA7076M,
SLA7077M, and SLA7078M
Motor Driver ICs***

*Motor
Drivers*

PART NUMBERS AND OPTIONS

The following are the product variants and optional features available for these variants of the SLA7070M series.

Not all combinations of standard models and product options are available in high-volume production quantities. For information on product availability, and assistance with determining the IC features that are the best fit for your application, please contact our sales office or representative.

NOTE

The following abbreviations are used throughout this document to refer to product variants:

- PR – Product with both Protection Circuitry and built-in R_{SInt} options
- R – Product with the built-in R_{SInt} option

Part Number	Protection	Output Current, I _{OUT} (A)	Sequencer	Blanking Time (μs)	Clock Edge
SLA7075MR	R _{SInt}	1	Microstep	1.7	Positive
SLA7075MPR	Protection Circuitry and R _{SInt}				
SLA7076MR	R _{SInt}	1.5			
SLA7076MPR	Protection Circuitry and R _{SInt}				
SLA7077MR	R _{SInt}	2			
SLA7077MPR	Protection Circuitry and R _{SInt}				
SLA7078MR	R _{SInt}	3			
SLA7078MPR	Protection Circuitry and R _{SInt}				

SLA7075M, SLA7076M, SLA7077M, and SLA7078M Motor Driver ICs

Motor
Drivers

ELECTRICAL CHARACTERISTICS, valid at $T_A = 25^\circ\text{C}$, $V_{BB} = 24\text{ V}$, $V_{DD} = 5\text{ V}$, applicable to both PR and R products, unless otherwise specified

Characteristics	Symbol	Test Conditions	Min.	Typ.	Max.	Units
Main Power Supply Current	I_{BB}	Normal mode	–	–	15	mA
	I_{BBS}	Sleep1 and Sleep2 modes	–	–	100	μA
Logic Power Current	I_{DD}		–	–	5	mA
MOSFET Breakdown Voltage	V_{DSS}	$V_{BB} = 44\text{ V}$, $I_{DS} = 1\text{ mA}$	–	–	–	V
Maximum Response Frequency	f_{clk}	Clock Duty Cycle = 50%	250	–	–	kHz
Logic Supply Voltage	V_{IL}		–	–	$0.25 \times V_{DD}$	V
	V_{IH}		$0.75 \times V_{DD}$	–	–	V
Logic Supply Current	I_{IL}		–	± 1	–	μA
	I_{IH}		–	± 1	–	μA
REF Input Voltage	V_{REF}	See pages 6 and 7	–	–	–	V
	V_{REFS}	Output OFF, Sleep1 mode, I_{BBS} in specification, sequencer = enable	2.0	–	V_{DD}	V
REF Input Current	I_{REF}		–	± 10	–	μA
SENSE Voltage	V_{Sint}	$V_{REF} = 0.1\text{ V to }0.5\text{ V}$, Step reference current ratio: 100%	$V_{REF} - 0.03$	V_{REF}	$V_{REF} + 0.03$	V
Sleep-Enable Recovery Time	t_{SE}	$V_{REF} = 2.0\text{ V} \rightarrow 1.5\text{ V}$	100	–	–	μs
Switching Time	t_{con}	Clock \rightarrow Output ON	–	2.0	–	μs
	t_{coff}	Clock \rightarrow Output OFF	–	1.5	–	μs

STEPPING CHARACTERISTICS, applicable to both PR and R products; representative values from SLA7070M series shown
Valid at $T_A = 25^\circ\text{C}$, $V_{BB} = 24\text{ V}$, $V_{DD} = 5\text{ V}$, unless otherwise specified

Characteristics	Symbol	Test Conditions	Min.	Typ.	Max.	Units
Step Reference Current Ratio	Mode F	$V_{REF} \approx V_{Sint} = 100\%$, $V_{REF} = 0.1\text{ to }0.5\text{ V}$	–	100	–	%
	Mode E		–	98.1	–	%
	Mode D		–	95.7	–	%
	Mode C		–	92.4	–	%
	Mode B		–	88.2	–	%
	Mode A		–	83.1	–	%
	Mode 9		–	77.3	–	%
	Mode 8		–	70.7	–	%
	Mode 7		–	63.4	–	%
	Mode 6		–	55.5	–	%
	Mode 5		–	47.1	–	%
	Mode 4		–	38.2	–	%
	Mode 3		–	29	–	%
	Mode 2		–	19.5	–	%
Mode 1	–	9.8	–	%		
Mo (Load) Output Voltage	V_{MOL}	$I_{MOL} = 1.25\text{ mA}$	–	–	1.25	V
	V_{MOH}	$I_{MOH} = -1.25\text{ mA}$	$V_{DD} - 1.25$	–	–	V
Mo (Load) Output Current	I_{MOL}		–	–	1.25	mA
	I_{MOH}		-1.25	–	–	mA
PWM Minimum On-Time	$t_{on(min)}$		–	1.7	–	μs
PWM Off-Time	t_{off1}	Mode 8 to Mode F	–	12	–	μs
	t_{off2}	Mode 4 to Mode 7	–	9	–	μs
	t_{off3}	Mode 1 to Mode 3	–	7	–	μs

SLA7075M, SLA7076M, SLA7077M, and SLA7078M Motor Driver ICs

Motor
Drivers

OUTPUT CHARACTERISTICS for both PR and R products
Valid at $T_A = 25^\circ\text{C}$, $V_{BB} = 24\text{ V}$, $V_{DD} = 5\text{ V}$, unless otherwise specified

Characteristics	Symbol	Test Conditions	Min.	Typ.	Max.	Units
$I_{OUT} = 1.0\text{ A}$ (SLA7075M)						
Output On Resistance	$R_{DS(ON)}$	$I_{DS} = 1\text{ A}$	–	0.7	0.85	Ω
Body Diode Forward Voltage	V_f	$I_f = 1\text{ A}$	–	0.85	1.1	V
$I_{OUT} = 1.5\text{ A}$ (SLA7076M)						
Output On Resistance	$R_{DS(ON)}$	$I_{DS} = 1.5\text{ A}$	–	0.45	0.6	Ω
Body Diode Forward Voltage	V_f	$I_f = 1.5\text{ A}$	–	1.0	1.25	V
$I_{OUT} = 2.0\text{ A}$ (SLA7077M)						
Output On Resistance	$R_{DS(ON)}$	$I_{DS} = 2\text{ A}$	–	0.25	0.4	Ω
Body Diode Forward Voltage	V_f	$I_f = 2\text{ A}$	–	0.95	1.2	V
$I_{OUT} = 3.0\text{ A}$ (SLA7078M)						
Output On Resistance	$R_{DS(ON)}$	$I_{DS} = 3\text{ A}$	–	0.18	0.24	Ω
Body Diode Forward Voltage	V_f	$I_f = 3\text{ A}$	–	0.95	2.1	V

BUILT-IN SENSE RESISTOR CHARACTERISTICS for PR and R products
Valid at $T_A = 25^\circ\text{C}$, $V_{BB} = 24\text{ V}$, $V_{DD} = 5\text{ V}$, unless otherwise specified

Characteristics	Symbol	Test Conditions	Min.	Typ.	Max.	Units
$I_{OUT} = 1.0\text{ A}$ (SLA7075MPR and SLA7075MR)						
Sense Resistor Rating*	R_{Sint}	Tolerance: $\pm 3\%$	0.296	0.305	0.314	Ω
REF Input Voltage	V_{REF}	Within specified current limit	0.1	–	0.3	V
$I_{OUT} = 1.5\text{ A}$ (SLA7076MPR and SLA7076MR)						
Sense Resistor Rating*	R_{Sint}	Tolerance: $\pm 3\%$	0.296	0.305	0.314	Ω
REF Input Voltage	V_{REF}	Within specified current limit	0.1	–	0.45	V
$I_{OUT} = 2.0\text{ A}$ (SLA7077MPR and SLA7077MR)						
Sense Resistor Rating*	R_{Sint}	Tolerance: $\pm 3\%$	0.199	0.205	0.211	Ω
REF Input Voltage	V_{REF}	Within specified current limit	0.1	–	0.4	V
$I_{OUT} = 3.0\text{ A}$ (SLA7078MPR and SLA7078MR)						
Sense Resistor Rating*	R_{Sint}	Tolerance: $\pm 3\%$	0.150	0.155	0.160	Ω
REF Input Voltage	V_{REF}	Within specified current limit	0.1	–	0.45	V

* R_{Sint} includes approximately 5 m Ω circuit resistance in addition to the resistance of the resistor itself.

PROTECTION CIRCUIT CHARACTERISTICS*

Valid at $T_A = 25^\circ\text{C}$, $V_{BB} = 24\text{ V}$, $V_{DD} = 5\text{ V}$, unless otherwise specified

Characteristics	Symbol	Test Conditions	Min.	Typ.	Max.	Units
PR products						
Overcurrent Sense Voltage	V_{OCP}	Motor coils shorted	0.65	0.7	0.75	V
FLAG Output Voltage	V_{FlagL}	$I_{FLAGL} = 1.25\text{ mA}$	–	–	1.25	V
	V_{FlagH}	$I_{FLAGH} = -1.25\text{ mA}$	$V_{DD} - 1.25$	–	–	V
FLAG Output Current	I_{FlagL}		–	–	1.25	mA
	I_{FlagH}		-1.25	–	–	mA

*Protection circuits work on the condition of $V_{Sint} \geq V_{OCP}$.

RECOMMENDED OPERATING RANGES, applicable to both PR and R products, unless otherwise specified

Characteristics	Symbol	Remarks	Min	Max	Units
Load (Motor) Supply Voltage	V_M		–	44	V
Main Power Supply Voltage	V_{BB}		10	44	V
Logic Supply Voltage	V_{DD}	Surge voltage at VDD pin should be less than $\pm 0.5\text{ V}$ to avoid malfunctioning in operation	3.0	5.5	V
Case Temperature	T_C	Measured at pin 12, without heat sink	–	90	$^\circ\text{C}$

ALLOWABLE POWER DISSIPATION

PR and R Products

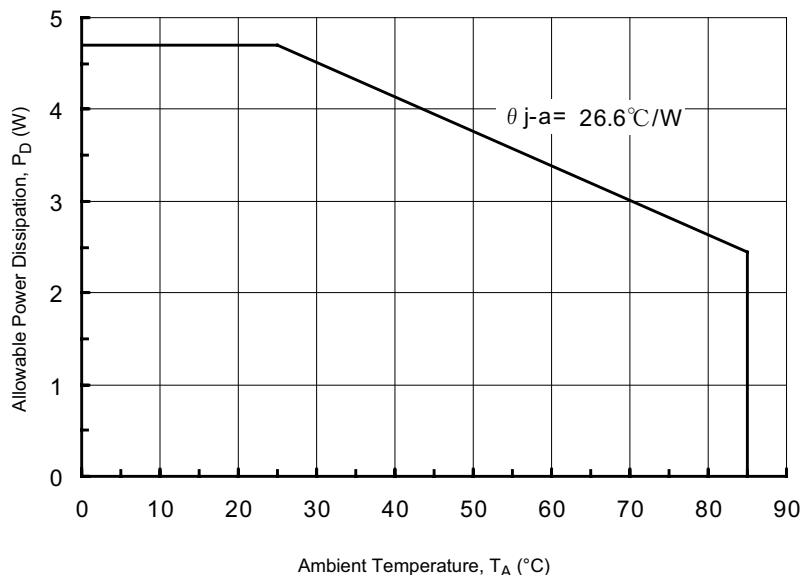

SLA7075M, SLA7076M, SLA7077M, and SLA7078M Motor Driver ICs

Motor
Drivers

FUNCTIONAL DESCRIPTION

PWM Current Control

The description in this section is applicable to the PR and R products.

- Blanking time

The actual operating waveforms on the SENSE_x pins when driving a motor are shown in figure 1. Immediately after PWM turns OFF, ringing (or spike) noise on the SENSE_x pins is observed for a few μ s. Ringing noise can be generated by various causes, such as capacitance between motor coils and inappropriate motor wiring.

Each pair of outputs is controlled by a fixed off-time (7 to 12 μ s, depending on stepping mode) PWM current-control circuit that limits the load current to a desired value, I_{TRIP} . Initially,

an output is enabled and current flows through the motor winding and the current-sense resistors. When the voltage across the current-sense resistor equals the DAC output voltage, V_{TRIP} , the current-sense comparator resets the PWM latch. This turns off the driver for the fixed off-time, during which the load inductance causes the current to recirculate for the off-time period. Therefore, if the ringing noise on the sense resistor equals and surpasses V_{TRIP} , PWM turns off.

To prevent this phenomenon, the blanking time is set to override signals from the current-sense comparator for a certain period right after PWM turns on (figure 2).

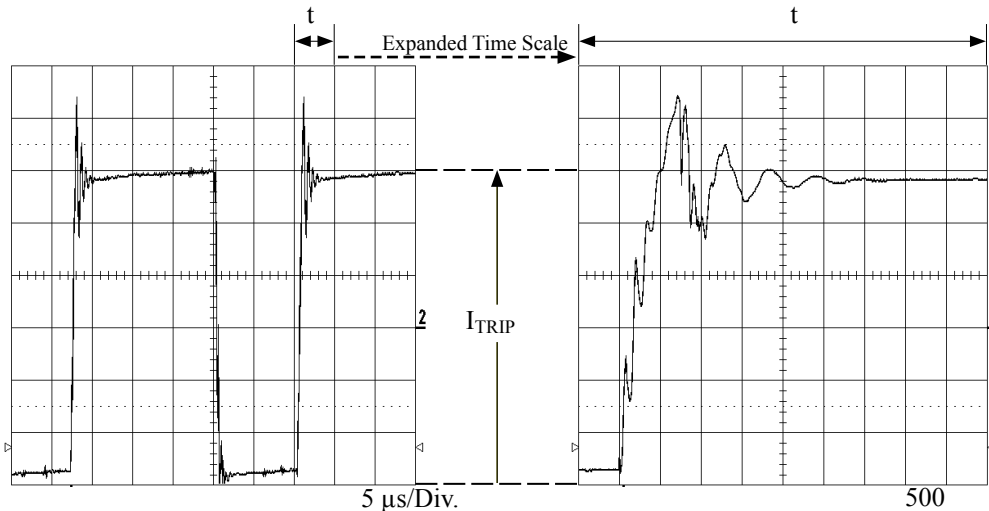

Figure 1. Operating waveforms on the SENSE_x pins during PWM chopping

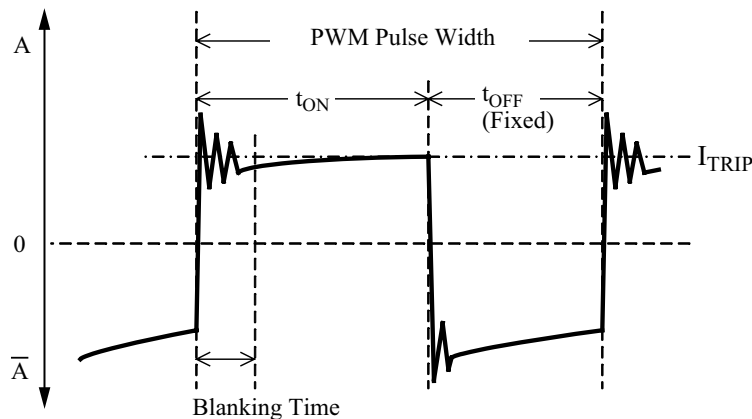

Figure 2. SENSE_x pins pattern during PWM control

PWM Off Period

The PWM off-time for the SLA7070M series is controlled as a fixed time by an internal oscillator. It also is switched in 3 levels by current proportion (see the Electrical Characteristics table).

In addition, the SLA7070M series provide a function that decreases losses occurring when the PWM turns off. This function dissolves back EMF stored in the motor coil at MOSFET turn-on, as well as at PWM turn-on (synchronous rectification operation).

Figure 3 shows the difference in back EMF generative system between the SLA7060M series and SLA7070M series. The SLA7060M series performs on-off operations using only the MOSFET on the PWM-on side, but the SLA7070M series also performs on-off operations using only the MOSFET on the PWM-off side. To prevent simultaneous switching of the MOSFETs at synchronous rectification operation, the IC has a dead time of approximately 0.5 μ s. During dead time, the back EMF flows through the body diode on the MOSFET.

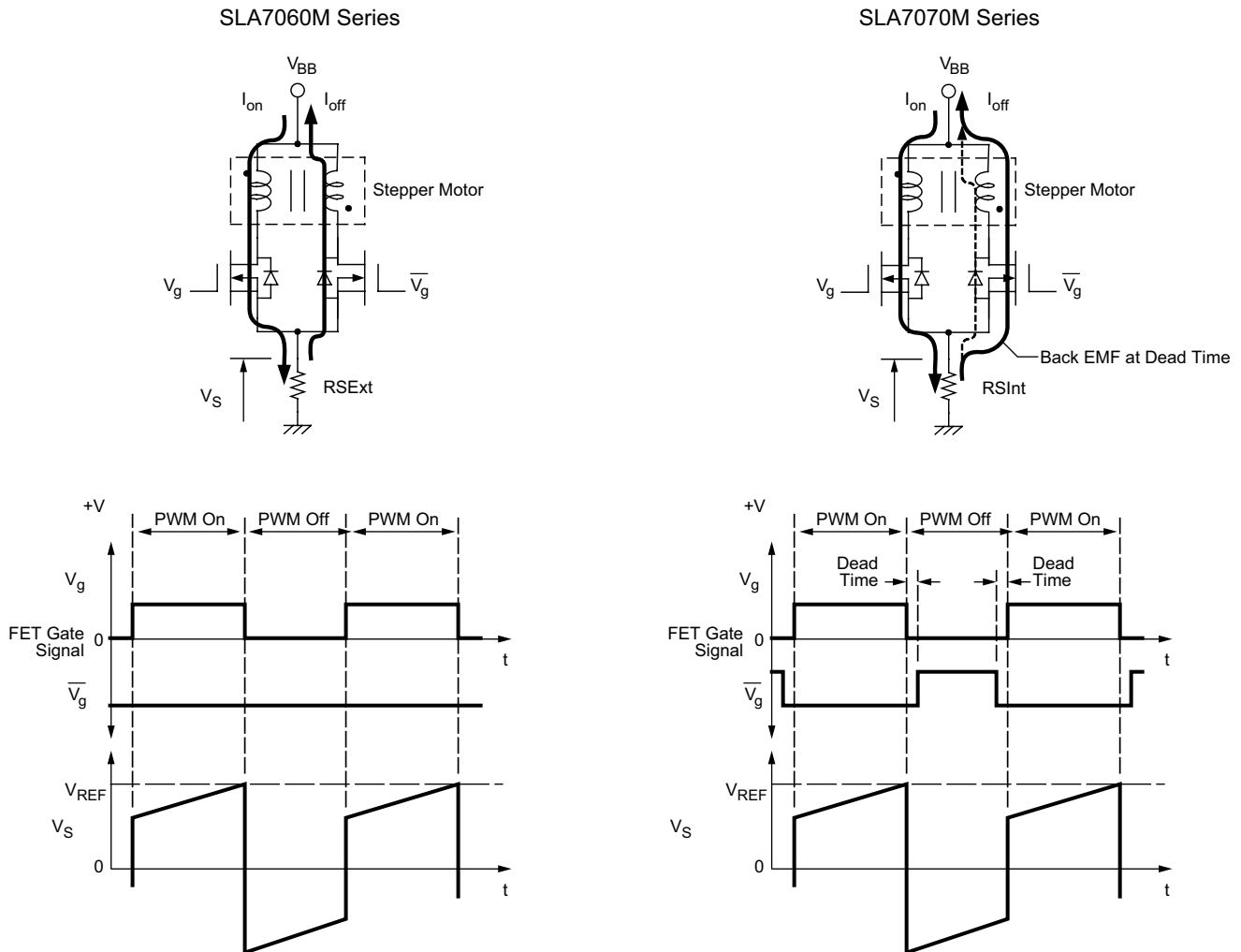

Figure 3. Synchronous rectification operation. During Dead Time, the Back EMF flows through the body diode of the MOSFET

SLA7075M, SLA7076M, SLA7077M, and SLA7078M Motor Driver ICs

Motor
Drivers

Protection Functions: PR Types

The PR types of the SLA7070M series include a motor coil short-circuit protection circuit and a motor coil open protection circuit. They are described in this section.

- Motor Coil Short-Circuit Protection (Load Short) Circuit

This protection circuit, embedded in the SLA7070M series, begins to operate when the device detects an increase in the voltage level on the sense resistor, V_{SInt} .

The voltage at which motor coil short-circuit protection starts its operation, V_{OCP} , is set at approximately 0.7 V. The out-

put is disabled at the time the protection circuit starts.

In order for the motor coil short-circuit protection circuit to operate, V_{SInt} must be greater than V_{OCP} .

Overcurrent that flows without passing the sense resistor is undetectable. To resume the circuit after protection operates, VDD must be cycled.

- Motor Coil Open Protection

Details of this functions is not disclosed yet due to our patent policy.

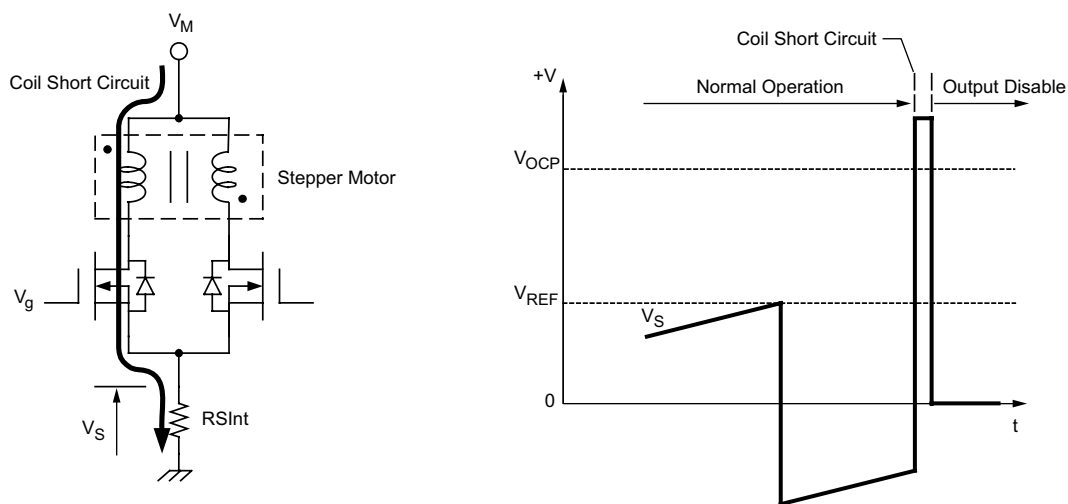
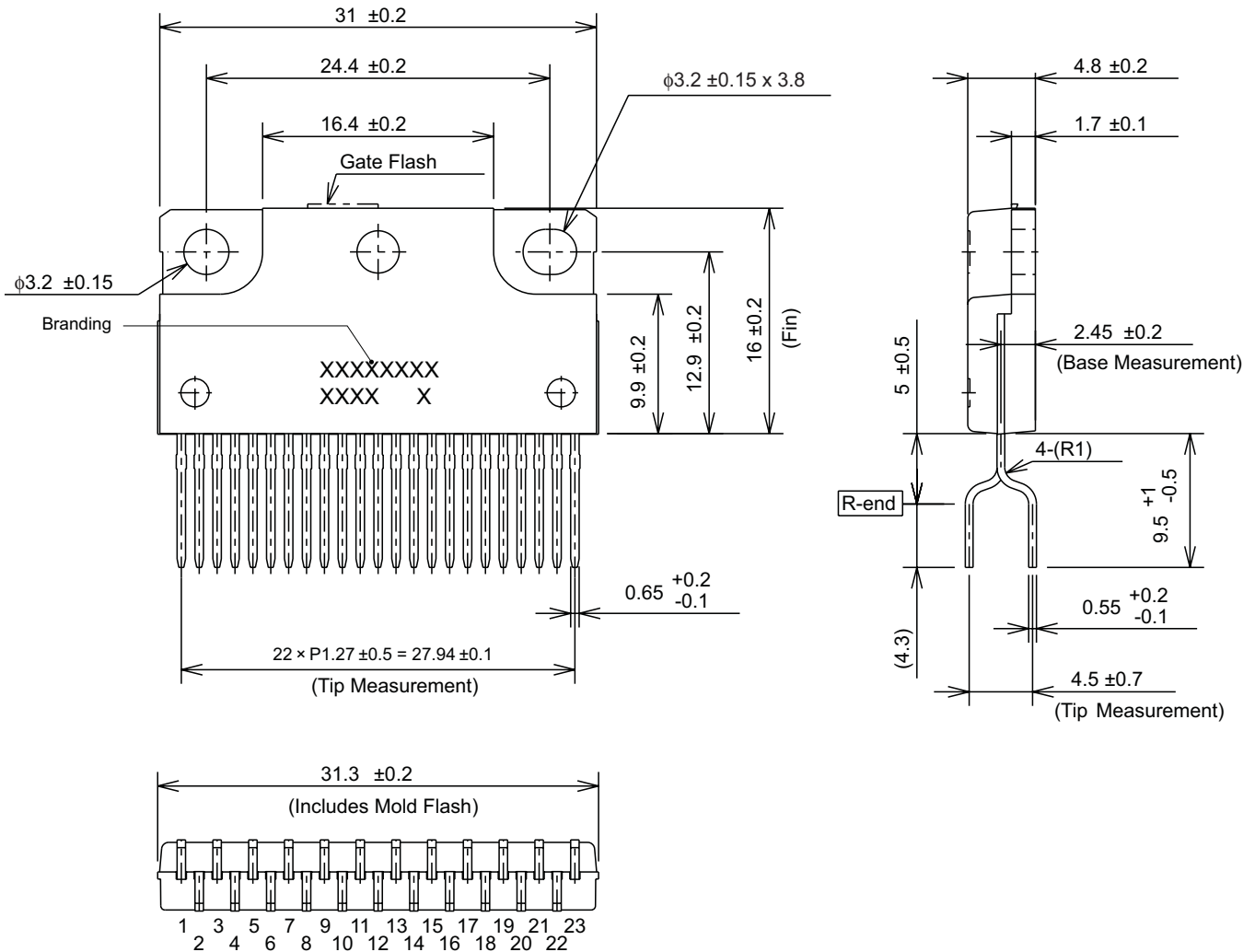

Figure 4. Motor coil short circuit protect circuit operation. Overcurrent that flows without passing the sense resistor is undetectable. To recover the circuit after protection operates, VDD must be cycled and started up again.

PACKAGE OUTLINE DRAWING, SLA-23 PIN



Terminal core material: Cu
Terminal treatment: Ni plating and solder dip
Leadform: 2151

Dimensions in millimeters

Branding:
1st line, type: SLA707xMR
2nd line-left, lot: YMDD

Where:
Y is the last digit of the year of manufacture
M is the month (1 to 9, O, N, D)
DD is the 2-digit date
2nd line-right, subtype: P for Protection Circuitry option; otherwise, blank



Leadframe plating Pb-free. Device composition includes high-temperature solder (Pb >85%), which is exempted from the RoHS directive.

***SLA7075M, SLA7076M,
SLA7077M, and SLA7078M
Motor Driver ICs***

*Motor
Drivers*

PACKING SPECIFICATIONS

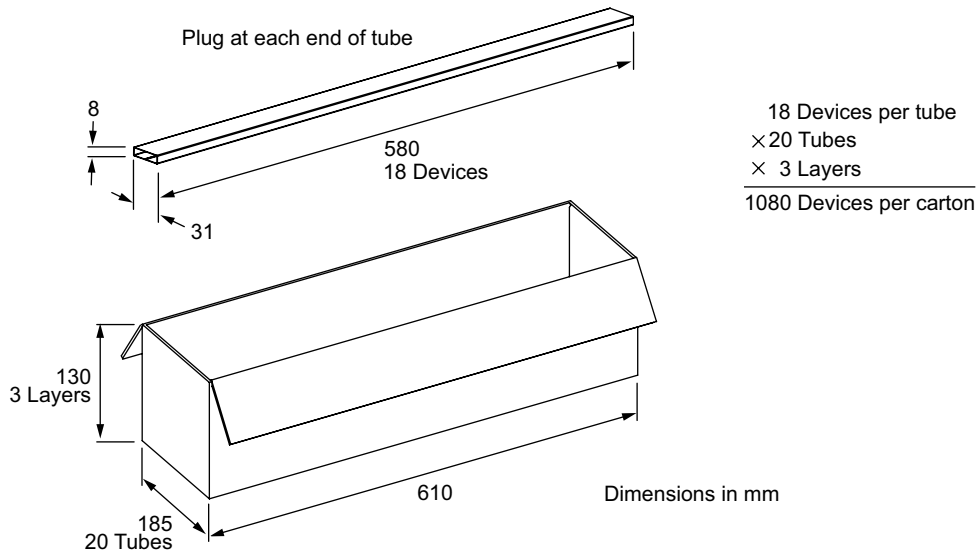

SLA7075M, SLA7076M, SLA7077M, and SLA7078M Motor Driver ICs

*Motor
Drivers*



WARNING — These devices are designed to be operated at lethal voltages and energy levels. Circuit designs that embody these components must conform with applicable safety requirements. Precautions must be taken to prevent accidental contact with power-line potentials. Do not connect grounded test equipment.

The use of an isolation transformer is recommended during circuit development and breadboarding.

The products described herein are manufactured in Japan by Sanken Electric Co., Ltd. for sale by Allegro MicroSystems, Inc.

Sanken and Allegro reserve the right to make, from time to time, such departures from the detail specifications as may be required to permit improvements in the performance, reliability, or manufacturability of its products. Therefore, the user is cautioned to verify that the information in this publication is current before placing any order.

When using the products described herein, the applicability and suitability of such products for the intended purpose shall be reviewed at the users responsibility.

Although Sanken undertakes to enhance the quality and reliability of its products, the occurrence of failure and defect of semiconductor products at a certain rate is inevitable.

Users of Sanken products are requested to take, at their own risk, preventative measures including safety design of the equipment or systems against any possible injury, death, fires or damages to society due to device failure or malfunction.

Sanken products listed in this publication are designed and intended for use as components in general-purpose electronic equipment or apparatus (home appliances, office equipment, telecommunication equipment, measuring equipment, etc.). Their use in any application requiring radiation hardness assurance (e.g., aerospace equipment) is not supported.

When considering the use of Sanken products in applications where higher reliability is required (transportation equipment and its control systems or equipment, fire- or burglar-alarm systems, various safety devices, etc.), contact a company sales representative to discuss and obtain written confirmation of your specifications.

The use of Sanken products without the written consent of Sanken in applications where extremely high reliability is required (aerospace equipment, nuclear power-control stations, life-support systems, etc.) is strictly prohibited.

The information included herein is believed to be accurate and reliable. Application and operation examples described in this publication are given for reference only and Sanken and Allegro assume no responsibility for any infringement of industrial property rights, intellectual property rights, or any other rights of Sanken or Allegro or any third party that may result from its use.

1234