

Aug.1.2022 Copyright 2022 HIROSE ELECTRIC CO., LTD. All Rights Reserved.
In case of consideration for using Automotive equipment / device which demand high reliability, kindly contact our sales window correspondents.

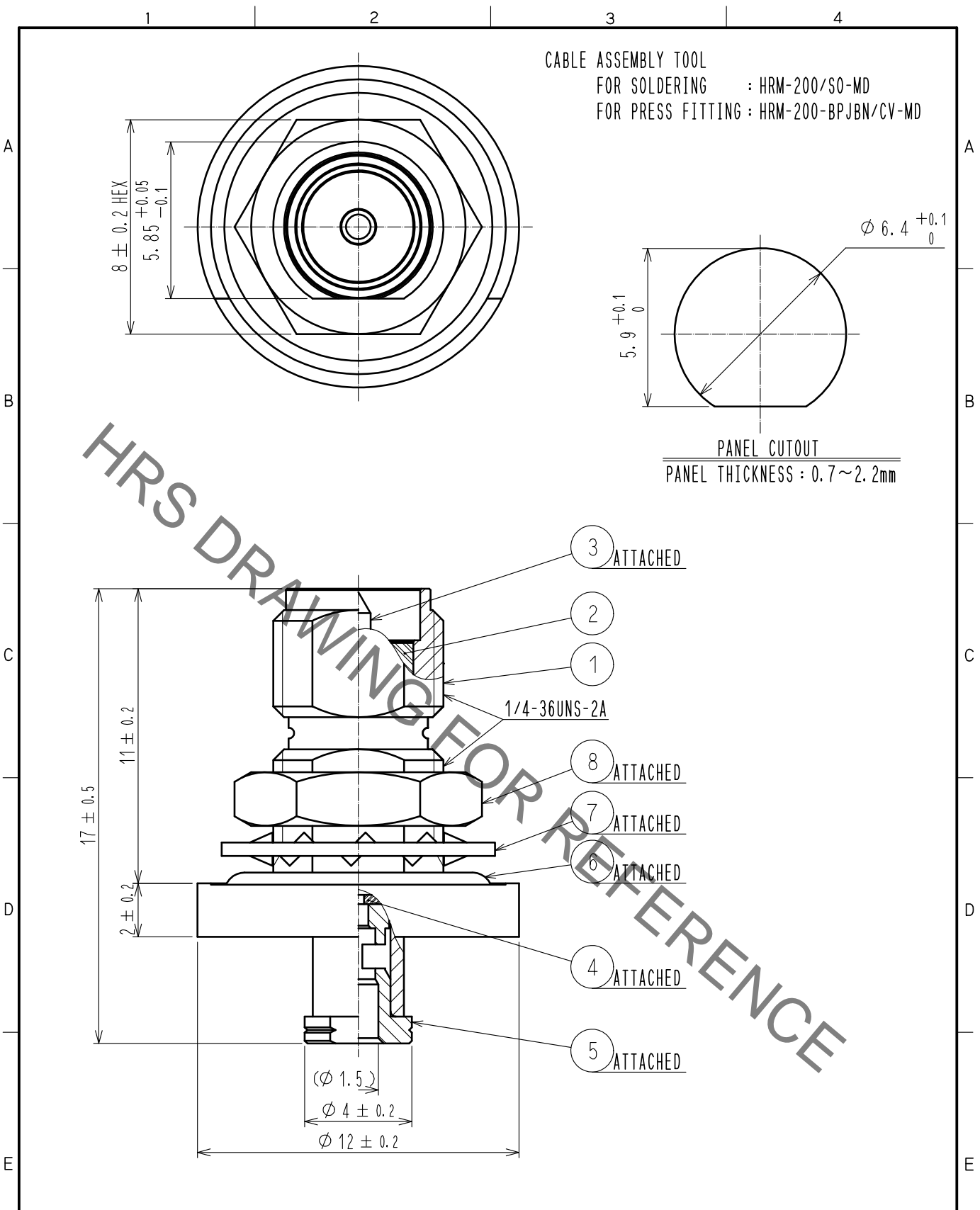

4	PTFE		8	BRASS	NICKEL PLATING
3	BRASS	GOLD PLATING	7	BRASS	NICKEL PLATING
2	PTFE		6	SILICONE RUBBER	(RED)
1	BRASS	NICKEL PLATING	5	BRASS	GOLD PLATING
NO.	MATERIAL	FINISH . REMARKS	NO.	MATERIAL	FINISH . REMARKS

UNITS mm		SCALE 5 : 1	COUNT 1	DESCRIPTION OF REVISIONS DIS-D-00003104	DESIGNED KY. SHIMIZU	CHECKED TO. KATAYAMA	DATE 18. 04. 27
APPROVED : TO. KATAYAMA 18. 03. 30				DRAWING NO. EDC-352879-00-00			
CHECKED : TO. KATAYAMA 18. 03. 30				PART NO. SMA(R)-200-066WBPJBN			
DESIGNED : KY. SHIMIZU 18. 03. 30				CODE NO. CL323-0948-6-00			
DRAWN : KY. SHIMIZU 18. 03. 30				1/1			