

Aug.1.2022 Copyright 2022 HIROSE ELECTRIC CO., LTD. All Rights Reserved.
 In case of consideration for using Automotive equipment / device which demand high reliability, kindly contact our sales window correspondents.

CABLE ASSEMBLY TOOL
 OUTER CONDUCTOR : P073-T-4

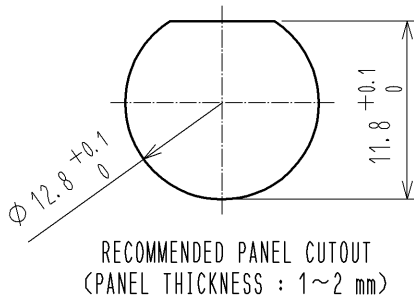
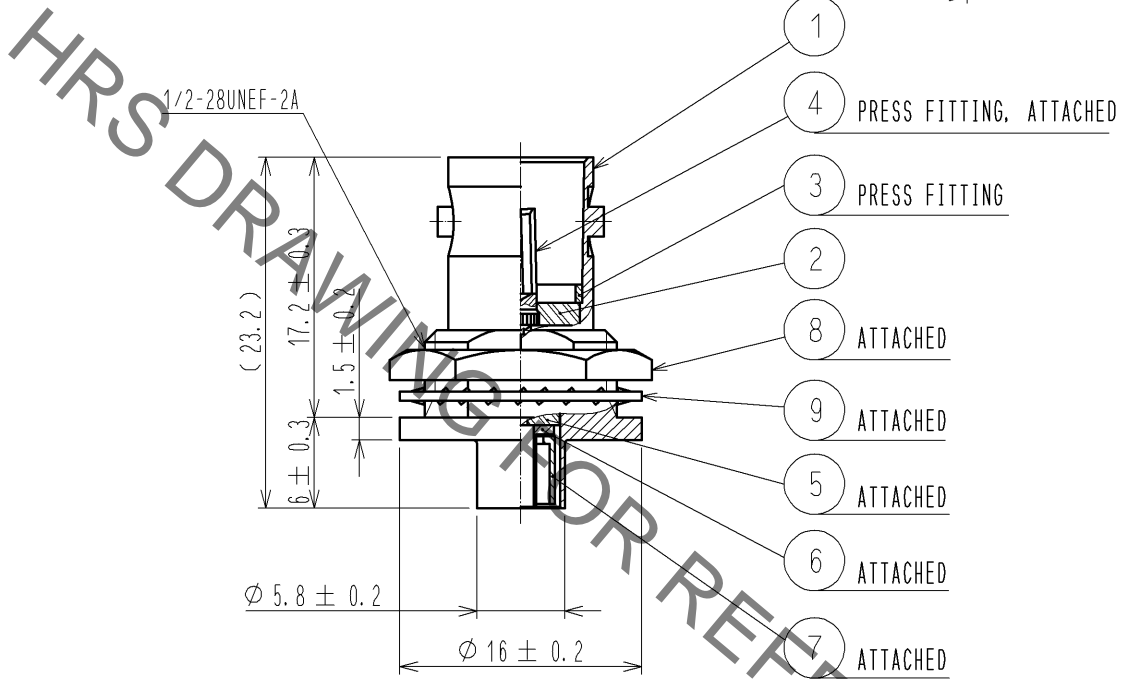
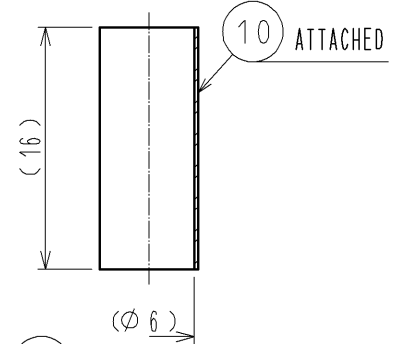
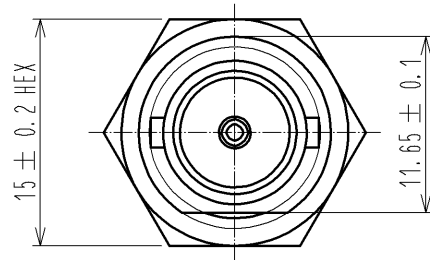

NOTE
 1. It is attached as a built-in block.
 (Ref.No. ④ and Ref.No. ⑤)

RoHS COMPLIANT

5	PTFE		10	HEAT SHRINK TUBING	POLYOLEFIN
4	BERYLLIUM COPPER	GOLD PLATING	9	STEEL	NICKEL PLATING
3	BRASS	NICKEL PLATING	8	BRASS	NICKEL PLATING
2	PTFE		7	BRASS	NICKEL PLATING
1	BRASS	NICKEL PLATING	6	BRASS	NICKEL PLATING
NO.	MATERIAL	FINISH , REMARKS	NO.	MATERIAL	FINISH , REMARKS

UNITS mm	SCALE 2 : 1	COUNT	DESCRIPTION OF REVISIONS	DESIGNED	CHECKED	DATE
HIROSE ELECTRIC CO., LTD.	APPROVED : MH. YAMANE	14. 01. 29	DRAWING NO.	EDC4-135315-40		
	CHECKED : TY. OZAKI	14. 01. 28	PART NO.	BNC(75)-BPJ-1.5CW-(P)(40)		
	DESIGNED : YI. FUNADA	14. 01. 27	CODE NO.	CL302-0388-2-40		
	DRAWN : YI. FUNADA	14. 01. 27		1/1		