

General Description

These N-channel enhanced VDMOSFETS Used advanced trench technology design, provided excellent R_{ds(on)} and low gate charge. Which accords with the RoHS standard.

Product Summary			
V _{DS}	R _{DS(on)} (mΩ) Typ	I _D (A)	Q _g (Typ)
60V	12 @ 10V	25	51nc

Features

- Fast switching
- Low on-resistance
- Low gate charge and input capacitance
- 100% avalanche tested

Mechanical Data

- Case: TO-220, ITO-220, TO-263, TO-262, TO-251, TO-252 Package

Application

- Switching applications

Ordering Information

Part No.	Package Type	Package	Quality(box)
D50N06	TO-220	Tube	1000
D50N06F	ITO-220	Tube	1000
D50N06D	TO-263	Tape & Reel	800
D50N06E	TO-262	Tube	1000
D50N06N	TO-251	Tube	1000
D50N06M	TO-252	Tape & Reel	3000

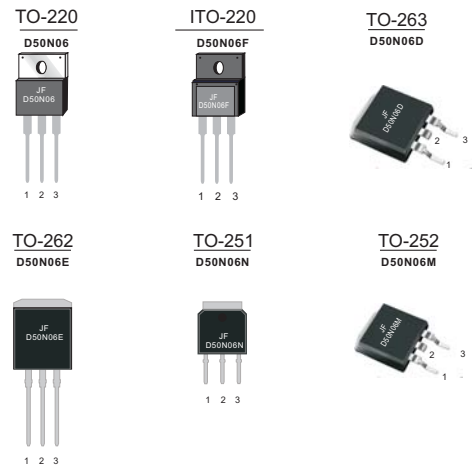

Block Diagram

Pin Definition:

1. Gate
2. Drain
3. Source

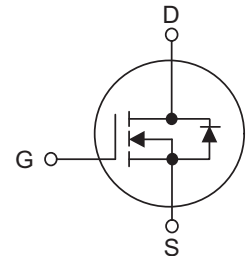

Table1 Absolute Maximum Ratings (T_C=25°C, unless otherwise specified)

Parameter	Symbol	D50N06/D50N06D/D50N06E D50N06M/D50N06N	D50N06F	Unit
Drain-Source Voltage	V _{DS}	60		V
Gate-Source Voltage	V _{GS}	±20		V
Continuous Drain Current	I _D	T _C =25°C	66	A
		T _C =100°C	50	
Pulsed Drain Current (Note 1)	I _{DM}	250		A
Single Pulse Avalanche Energy(Note 2)	E _{AS}	289		mJ
Avalanche Current(Note 1)	I _{AR}	34		A
Power Dissipation T _C =25°C	P _D	88	42	W
Operating Junction and Storage Temperature	T _J /T _{STG}	-55 ~ +175		C

Table 2. Thermal Characteristics

Parameter	Symbol	D50N06/D50N06D/D50N06E D50N06M/D50N06N	D50N06F	Unit
Thermal resistance Junction to Ambient	$R_{\theta JA}$	75	75	C/W
Thermal resistance Junction to Case	$R_{\theta JC}$	1.7	3.57	C/W

Table 3. Electrical Characteristics ($T_J=25\text{ C}$, unless otherwise specified)

Parameter	Symbol	Test Conditions	Min	Typ	Max	Unit
Off Characteristics						
Drain-Source Breakdown Voltage	BV_{DSS}	$V_{GS}=0V, I_D=250\mu A$	60			V
Drain-Source Leakage Current	I_{DSS}	$V_{DS}=60V, V_{GS}=0V$			1	μA
Gate- Source Leakage Current	Forward	$V_{GS}=20V, V_{DS}=0V$			100	nA
	Reverse	$V_{GS}=-20V, V_{DS}=0V$			-100	nA
On Characteristics(Note 4)						
Gate Threshold Voltage	$V_{GS(TH)}$	$V_{DS}=V_{GS}, I_D=250\mu A$	2		4	V
Static Drain-Source On-State Resistance	$R_{DS(ON)}$	$V_{GS}=10V, I_D=25A$		12	18	m Ω
Dynamic Characteristics(Note 5)						
Input Capacitance	C_{ISS}	$V_{DS}=20V, V_{GS}=0V, f=1MHz$		2068		pF
Output Capacitance	C_{OSS}			200		pF
Reverse Transfer Capacitance	C_{RSS}			150		pF
Switching Characteristics (Note 5)						
Turn-On Delay Time	$t_d(on)$	$V_{DD}=20V, I_D=1A,$ $V_{GS}=10V, R_G=6\Omega$		14		ns
Turn-On Rise Time	t_R			13		ns
Turn-Off Delay Time	$t_d(off)$			20		ns
Turn-Off Fall Time	t_f			7.2		ns
Total Gate Charge	Q_G	$V_{DS}=20V, I_D=20A,$ $V_{GS}=10V$		51		nC
Gate-Source Charge	Q_{GS}			11		nC
Gate-Drain Charge	Q_{GD}			17		nC
Drain-Source Diode Characteristics and Maximum Ratings						
Drain-Source Diode Forward Voltage	V_{SD}	$V_{GS}=0V, I_S=50A$		0.85	1.1	V
Maximum Continuous Drain-Source Diode Forward Current	I_S				50	A
Reverse Recovery Time	t_{rr}	$V_{GS}=0V, I_F=20A$		28		ns
Reverse Recovery Charge	Q_{RR}	$di/dt=100A/\mu s$ (Note 1)		24		nC

Notes : 1 Repetitive Rating: Pulse width limited by maximum junction temperature

2 $L=0.5mH, I_D=34A, V_{DD}=50V$, Starting $T_J=25^\circ C$

4 Pulse Test: Pulse width $\leq 300\mu s$, Duty cycle $\leq 2\%$

5 Guaranteed by design, not subject to production



Typical Characteristics Diagrams

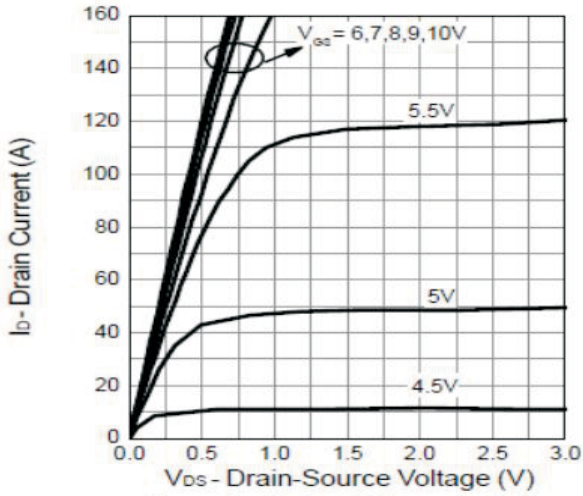

Figure 1 Output Characteristics

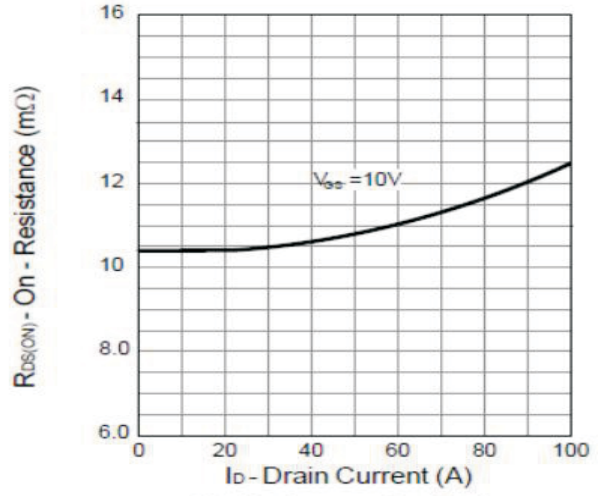

Figure 2 Drain-Source On Resistance

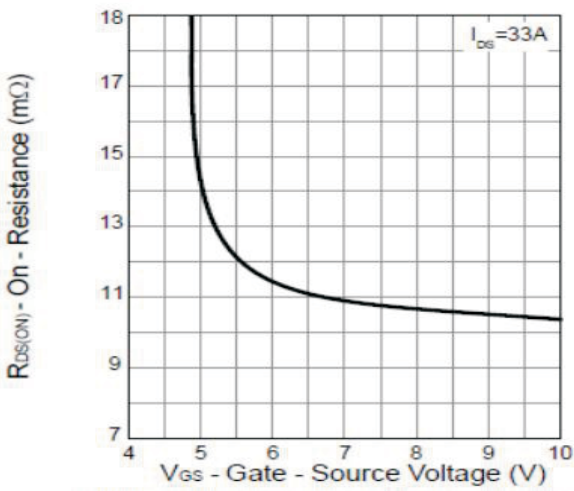

Figure 3 Drain-Source On Resistance

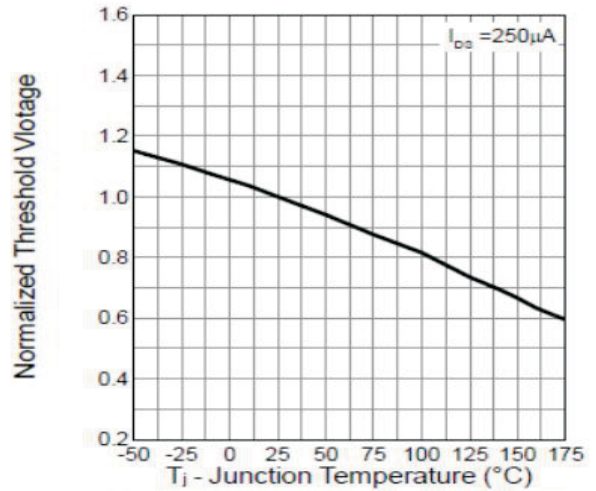

Figure 4 Gate Threshold Voltage

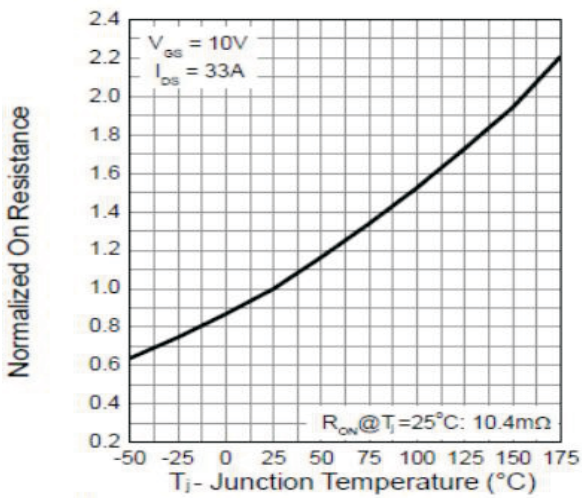

Figure 5 Drain-Source On Resistance

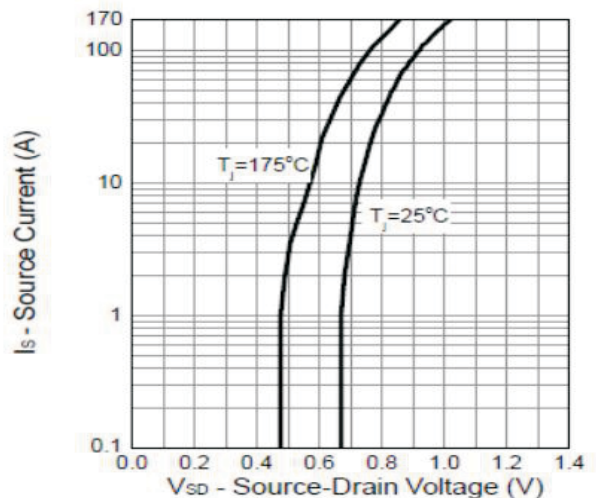

Figure 6 Source-Drain Diode Forward



Typical Characteristics Diagrams

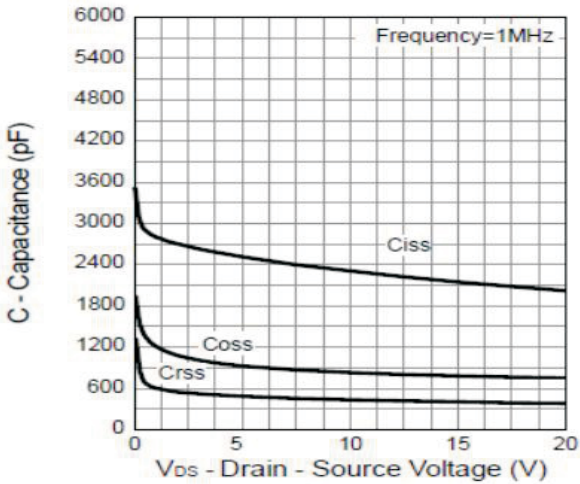

Figure 7 Capacitance

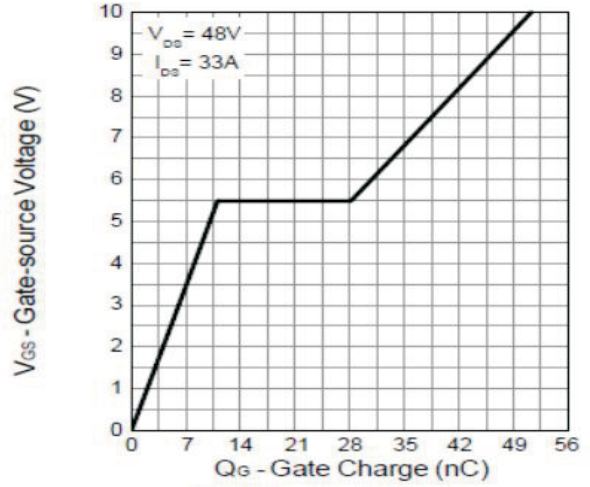

Figure 8 Gate Charge

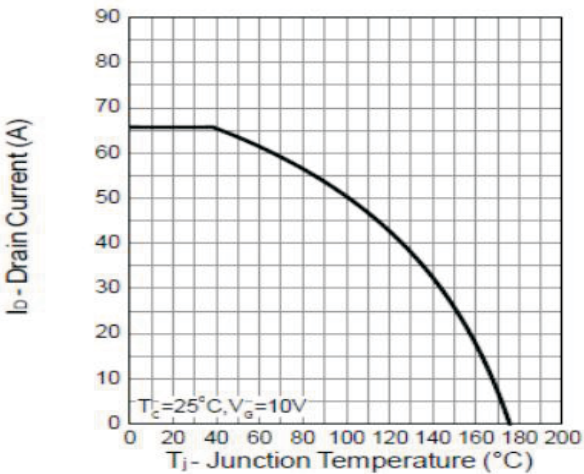

Figure 9 Drain Current

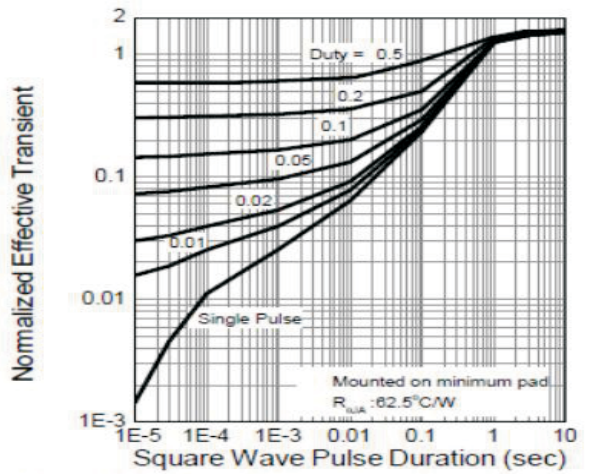

Figure 10 Thermal Transient Impedance

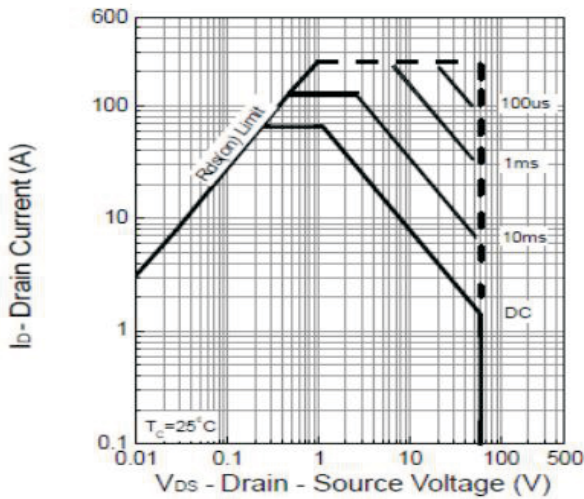

Figure 11 Safe Operation Area

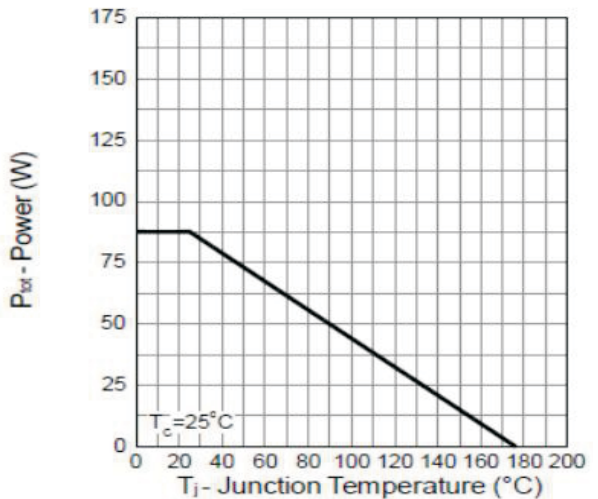

Figure 12 Power Dissipation

Typical Characteristics Diagrams

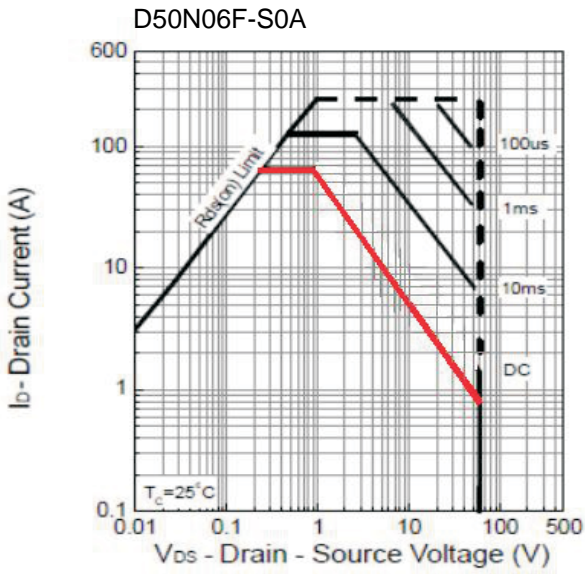

Figure 13 Safe Operation Area

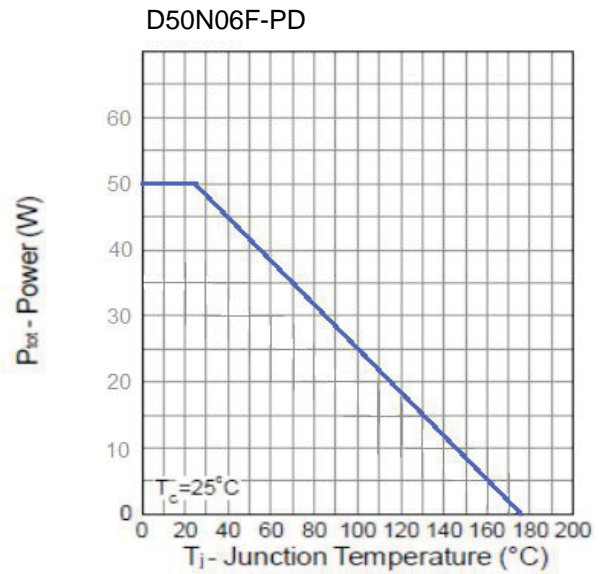
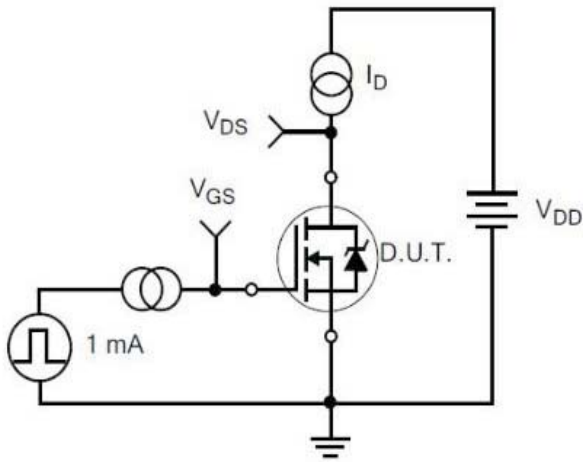
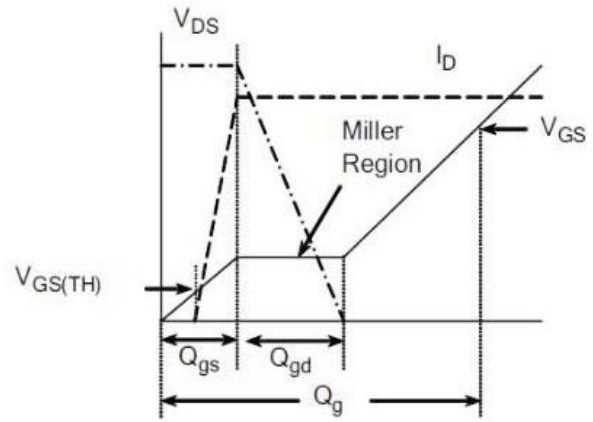

Figure 14 Power Dissipation

Typical Test Circuit



1) Gate Charge Test Circuit



2) Gate Charge Waveform

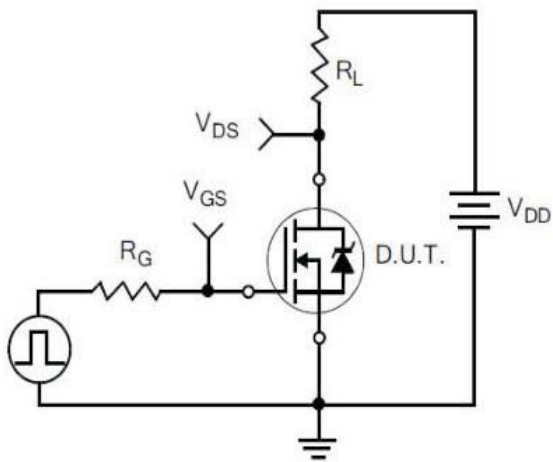

3) Resistive Switching Test Circuit

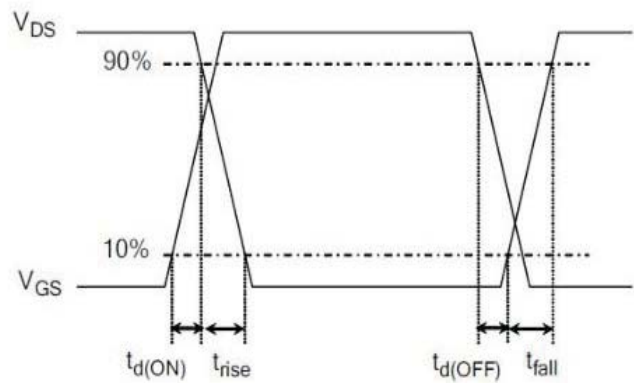

4) Resistive Switching Waveforms

Typical Test Circuit

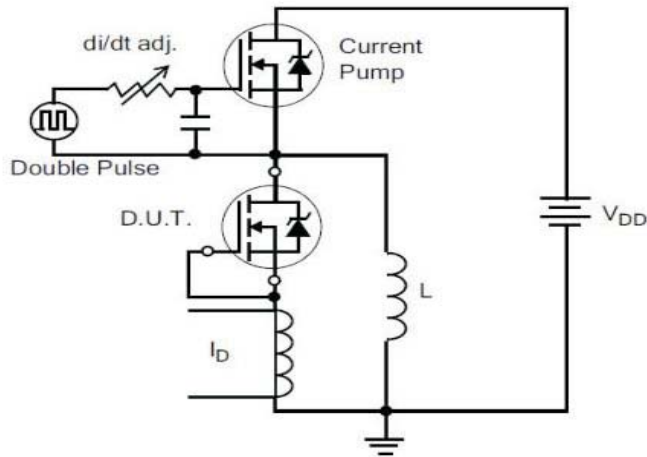

5) Diode Reverse Recovery Test Circuit

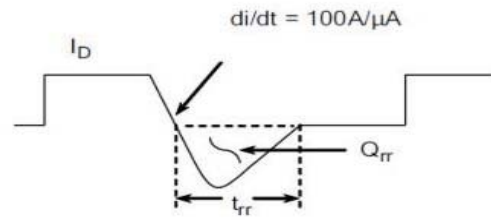

6) Diode Reverse Recovery Waveform

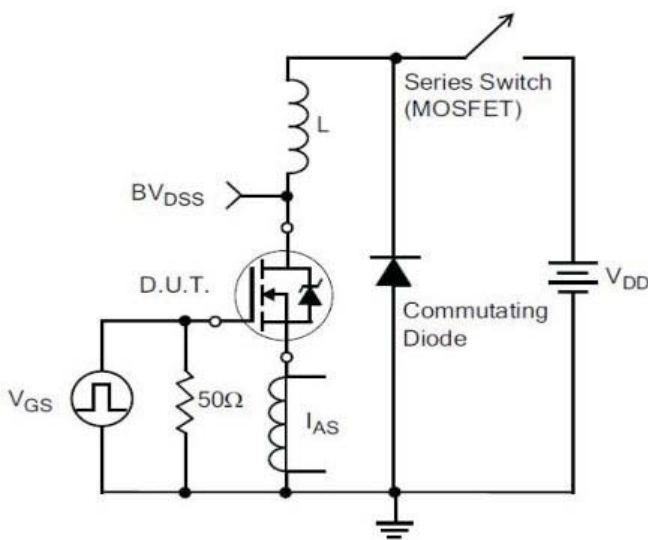

7) . Unclamped Inductive Switching Test Circuit

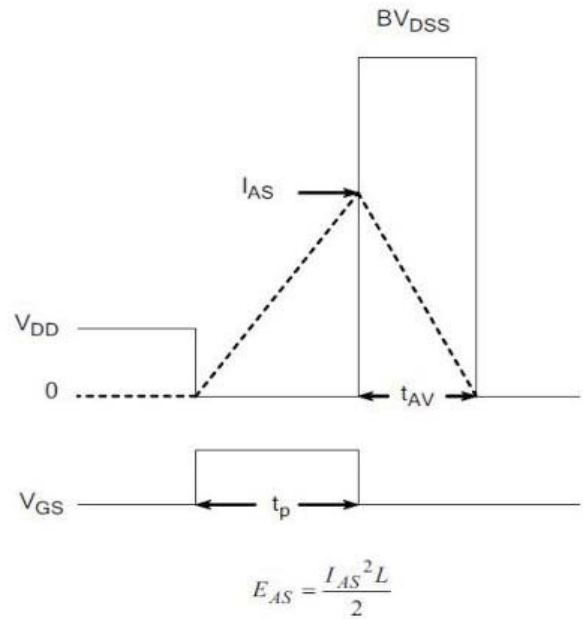

8) Unclamped Inductive Switching Waveforms

Product Names Rules

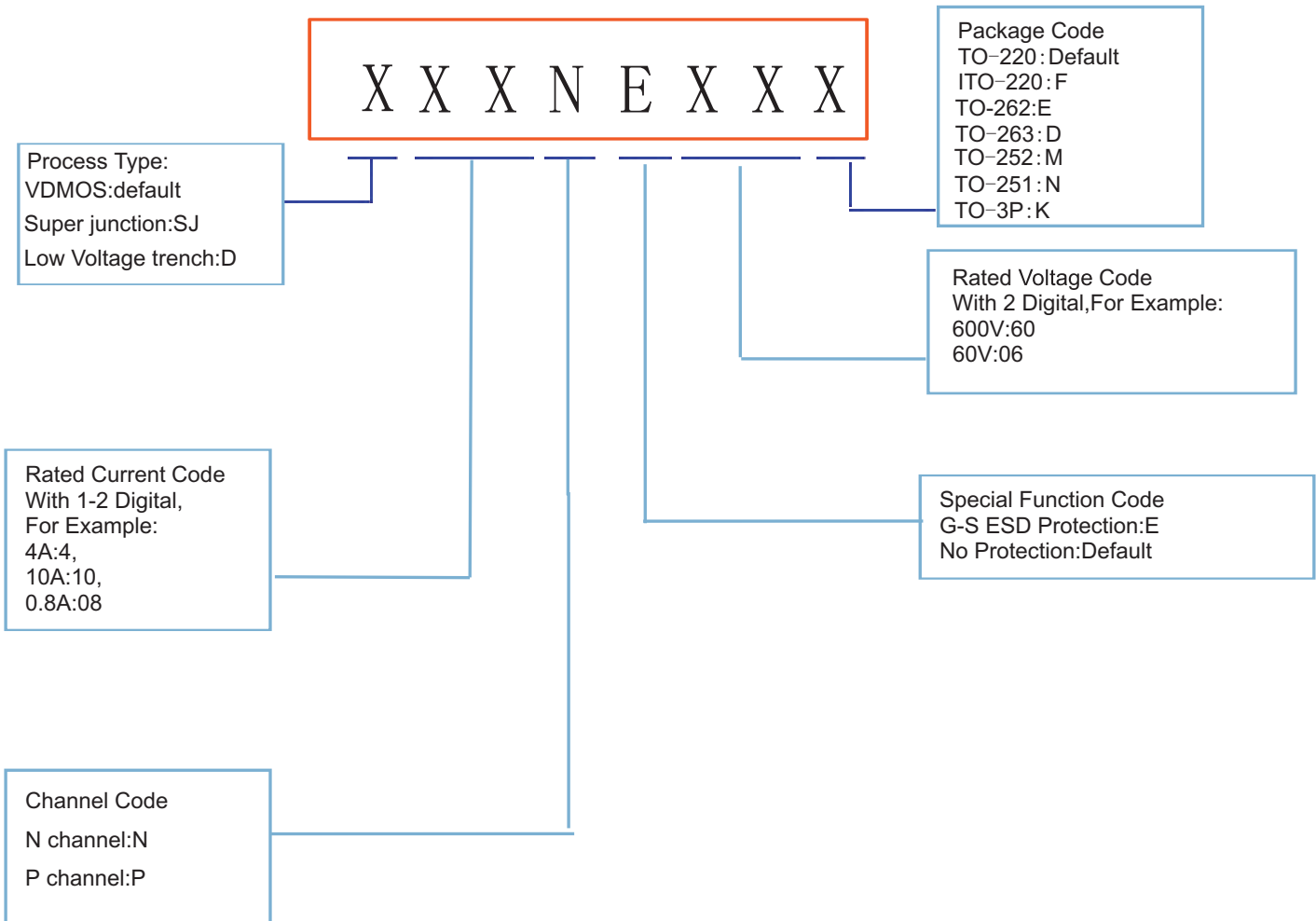

Dimensions

TO-220 PACKAGE OUTLINE DIMENSIONS

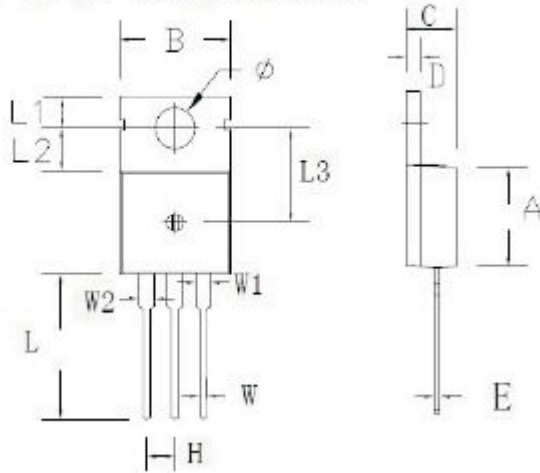

Symbol	Dimensions In Millimeters		Dimensions In Inches	
	min.	max.	min.	max.
A	8.80	9.30	0.346	0.366
B	9.70	10.30	0.382	0.406
C	4.25	4.75	0.167	0.187
D	1.20	1.45	0.047	0.057
E	0.40	0.60	0.016	0.024
H	2.54 TYP		0.100 TYP	
W	0.60	0.95	0.024	0.037
W1	1.05	1.45	0.041	0.057
W2	1.20	1.60	0.047	0.063
L	12.60	13.40	0.496	0.528
L1	2.45	2.95	0.096	0.116
L2	3.45	3.95	0.136	0.156
L3	8.15	8.65	0.321	0.341
ϕ	3.50	3.90	0.138	0.154

ITO-220 PACKAGE OUTLINE DIMENSIONS

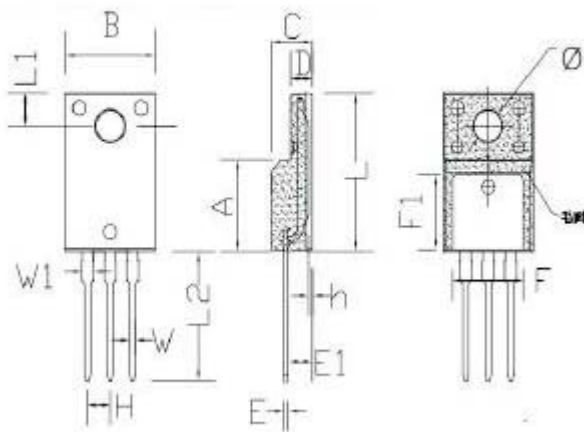

Symbol	Dimensions In Millimeters		Dimensions In Inches	
	min.	max.	min.	max.
A	8.80	9.30	0.346	0.366
B	10.00	10.50	0.394	0.413
C	4.30	4.90	0.169	0.193
D	2.30	2.70	0.091	0.106
L	15.55	16.15	0.612	0.636
h	0.40	0.60	0.016	0.024
L1	3.15	3.55	0.124	0.140
L2	12.65	13.35	0.498	0.526
W	0.70	0.90	0.028	0.035
W1	1.15	1.55	0.045	0.061
H	2.54 TYP		0.100 TYP	
E	0.48	0.53	0.019	0.021
ϕ	2.90	3.40	0.114	0.134
E1	2.40	2.90	0.094	0.114
F	7.75	8.25	0.305	0.325
F1	7.35	7.85	0.289	0.309

Dimensions

TO-263 PACKAGE OUTLINE DIMENSIONS

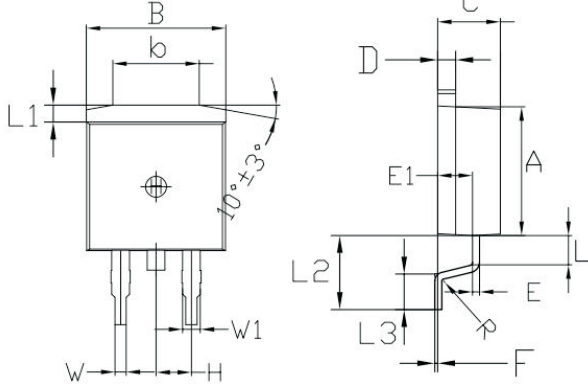

Symbol	Dimensions In Millimeters		Dimensions In Inches	
	min.	max.	min.	max.
A	8.80	9.30	0.346	0.366
B	9.70	10.30	0.382	0.406
C	4.25	4.75	0.167	0.187
D	1.20	1.45	0.047	0.057
E	0.40	0.60	0.016	0.024
L	1.90	2.30	0.075	0.091
L1	1.15	1.45	0.045	0.057
R	0.24	0.26	0.0095	0.0102
W	0.80	0.82	0.0315	0.0323
W1	1.20	1.30	0.047	0.051
H	2.54 TYP		0.200 TYP	
b	5.50	6.50	0.216	0.256
E1	2.4	2.6	0.0946	0.1024
L2	5.20	5.80	0.205	0.228
L3	2.20	3.20	0.087	0.126
F	0.03	0.23	0.0012	0.0091

TO-262 PACKAGE OUTLINE DIMENSIONS

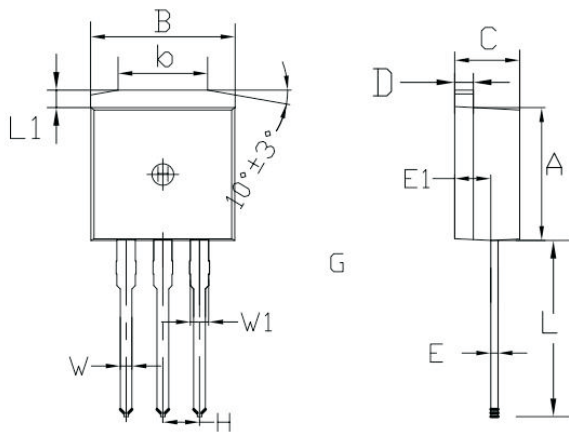

Symbol	Dimensions In Millimeters		Dimensions In Inches	
	min.	max.	min.	max.
A	8.80	9.30	0.346	0.366
B	9.70	10.30	0.382	0.406
C	4.25	4.75	0.167	0.187
D	1.20	1.45	0.047	0.057
E	0.40	0.60	0.016	0.024
L	12.25	13.75	0.482	0.541
L1	1.15	1.45	0.045	0.057
E1	2.4	2.6	0.0945	0.1024
W	0.80	0.82	0.0315	0.034
W1	1.20	1.30	0.047	0.051
H	2.54 TYP		0.200 TYP	
b	5.50	6.50	0.216	0.256

Dimensions

TO-251 PACKAGE OUTLINE DIMENSIONS

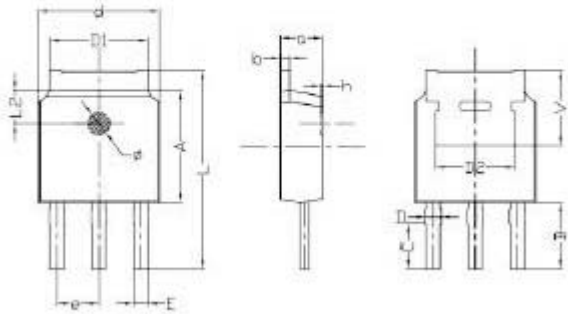

Symbol	Dimensions In Millimeters		Dimensions In Inches	
	min.	max.	min.	max.
a	2.20	2.40	0.087	0.0946
b	0.46	0.58	0.018	0.023
C	2.45	2.65	0.097	0.104
D	0.80	0.90	0.032	0.035
d	6.30	6.70	0.248	0.264
D1	5.00	5.50	0.197	0.217
D2	TYP 4.83		TYP 0.190	
A	5.80	6.20	0.228	0.244
e	2.19	2.39	0.086	0.094
L	10.40	11.00	0.4098	0.4334
B	3.50	3.70	0.1379	0.1458
L2	1.5	1.8	0.059	0.071
φ	1.10	1.30	0.0433	0.0512
h	0.00	0.30	0.000	0.012
V	5.25	5.85	0.207	0.230
E	0.60	0.80	0.0236	0.0315

TO-252 PACKAGE OUTLINE DIMENSIONS

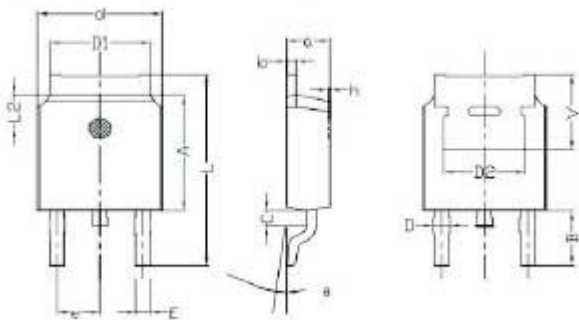

Symbol	Dimensions In Millimeters		Dimensions In Inches	
	min.	max.	min.	max.
a	2.20	2.40	0.087	0.095
b	0.46	0.58	0.018	0.023
c	0.70	0.90	0.028	0.035
D	0.80	1.00	0.032	0.039
d	6.30	6.70	0.248	0.264
D1	5.00	5.50	0.197	0.217
D2	TYP 4.83		TYP 0.190	
A	5.80	6.20	0.228	0.244
e	2.19	2.39	0.086	0.094
L	9.40	10.40	0.370	0.409
B	2.6	3.2	0.102	0.126
L2	1.5	1.8	0.059	0.071
θ	0	8	0	8
h	0	0.3	0	0.012
V	5.25	5.85	0.207	0.230

Friendship Reminder

■ JiNan JingHeng (hereinafter referred to as JH) reserves the right to make changes to this document and its products and specifications at anytime without notice.

■ Customers should obtain and confirm the latest product information and specifications before final design, purchase or use.

■ JH makes no warranty, representation or guarantee regarding the suitability of its products for any particular purpose, nor does JH assume any liability for application assistance or customer product design.

■ JH does not warrant or accept any liability with products which are purchased or used for any unintended or unauthorized application.

■ No license is granted by implication or otherwise under any intellectual property rights of JH.

■ JH's products are not authorized for use as critical components in life support devices or systems without express written approval of JH.