



**CMOSIS / AWAIBA**

is now

# Member of the ams Group

The technical content of this CMOSIS / AWAIBA document is still valid.

**Contact information:**

**Headquarters:**

ams AG

Tobelbader Strasse 30

8141 Premstaetten, Austria

Tel: +43 (0) 3136 500 0

e-Mail: [ams\\_sales@ams.com](mailto:ams_sales@ams.com)

Please visit our website at [www.ams.com](http://www.ams.com)

# NanEye NanEye Stereo Module

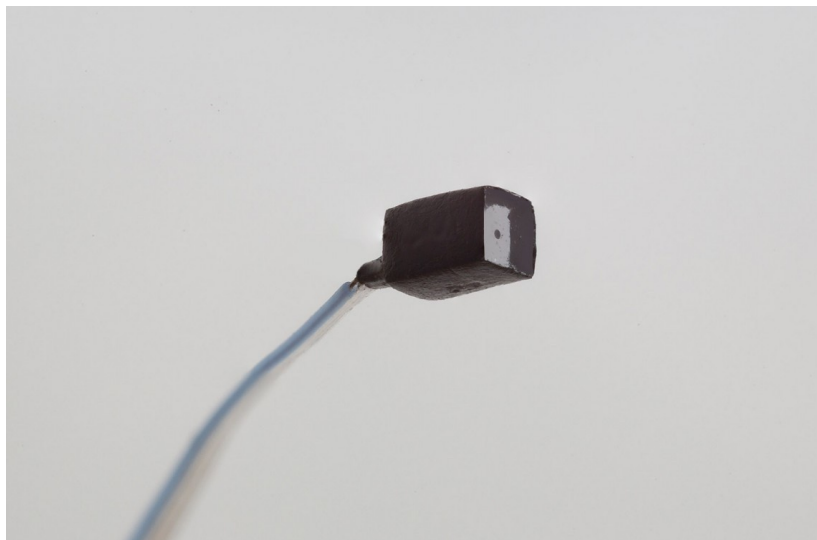

## Modifications and Updates

<i>Version</i>	<i>Date</i>	<i>Modifications</i>	<i>Author</i>
4.3	09-06-15	Updated Document	Fátima Baptista
4.4	06-10-15	Updated Package Options	Fátima Baptista
4.5	27-12-16	Updated Cable Pinout	José Félix
4.6	01-03-17	Updated Table 1 and Table 3	Fátima Baptista

## Table of Contents

1.Overview.....	4
2.NanEye Block Diagram.....	5
3.NanEye and NanEye Stereo Specifications.....	6
4.NanEye Power Consumption .....	7
5.Spectral Response .....	8
5.1Relative Spectral Response.....	8
5.2Color Matrix.....	9
5.2.1Filter transmission for RGB Bayer pattern sensor versions .....	10
6.Frame Rate.....	11
6.1Relation FPS vs Voltage.....	11
7.Cable Pinout.....	12
8.Mechanical Dimensions.....	13
8.1NanEye with Lens and Cable Soldered Dipped (Bended).....	13
8.2NanEye with Lens and Cable Soldered Dipped 90° (Not Bended).....	14
8.3NanEye Stereo.....	15
9.Optic.....	16
10.Package Options.....	19
10.1NanEye and NanEye Module.....	19
10.2NanEye Stereo Module.....	20
11.Miscellaneous.....	21

## Index of Tables

Table 1: NanEye and NanEye Stereo Specifications.....	6
Table 2: NanEye Power Consumption.....	7
Table 3: Package Options for NanEye and NanEye Module.....	19
Table 4: Package optins for NanEye Stereo Module.....	20

## Index of Figures

Figure 1: NanEye Simplified Block Diagram.....	5
Figure 2: Relative Spectral Response.....	8
Figure 3: Coloured Versions Bayer Pattern Matrix.....	9
Figure 4: Filter Relative Responsivity .....	10
Figure 5: Relation between FPS and Voltage. Blue - typical, Red - max and min values.....	11
Figure 6: Identification of cable pin out for 4 cables (GND is normally colour marked).....	12
Figure 7: Identification of cable pin out for 6 cables (FLEX PCB connector).....	12
Figure 8: Measurements of the NANEYE module.....	13
Figure 9: Measurements of the NANEYE module.....	14
Figure 10: Measurements of the NANEYE Stereo module (in mm).....	15
Figure 11: NanEye CTF measures.....	18

## 1. Overview

NanEye is a tiny camera module which consists of a CMOS image sensor with a footprint size of 1mm x 1mm and, optionally, adapted miniature optics. The device is mounted on a flat ribbon cable measuring up to 2m in length that connects to the Awaiba base station. However, if the customer requirements are discussed, it may be possible to assemble a slightly longer cable (up to 3m). The base station is connected to a PC with a standard USB cable measuring up to 5m.

NanEye Stereo offers the smallest physical dimensions of a digital 3D, a true system on chip camera head with fully self timed readout sequencing, AD conversion to 10 bit and bit serial data transmission over LVDS. With it's 2 x 250 x 250 pixels at 3um pitch the sensors provide clear and sharp images with outstanding MTF in a very compact size. Footprint of just 2.2x1mm and height of 1.6mm (with integrated optics), due to Wafer Level packaging high precision of the 2 camera heads.



**Note:** *The NanEye Module and NanEye Stereo Module system is NOT supplied sterile! Medical use of the system may lead to serious harm, illness or death!*

## 2. NanEye Block Diagram

The NanEye image sensor is based on CMOS technology and is a system on chip, which means that no external component close to the sensor is needed to run the sensor, not even an external capacitor.

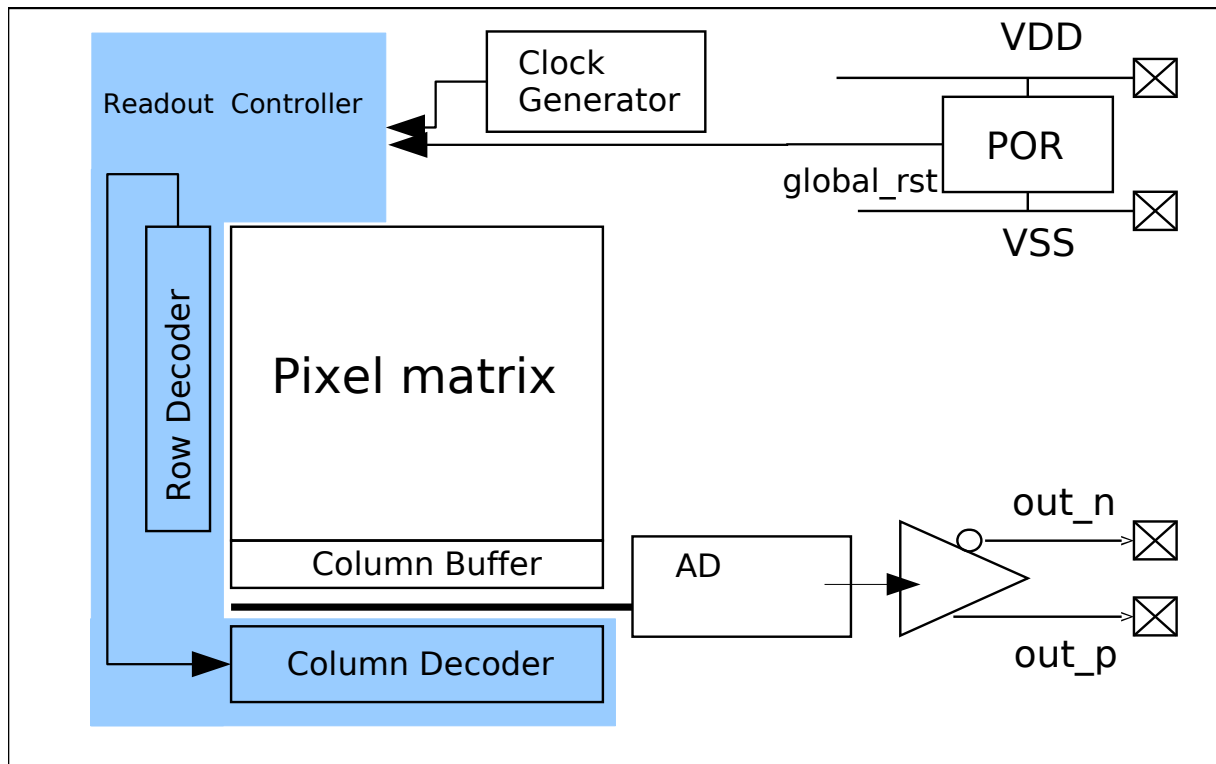

Figure 1: NanEye Simplified Block Diagram

### 3. NanEye and NanEye Stereo Specifications

Parameter	NanEye	NanEye Stereo	Remark
Number of Pixels	62k - 249 x 250	125KP – 500 x 250	
Pixel size	3µm x 3µm		
Colour	Bayer Pattern RGB		B&W version on request
Shutter	Rolling		
Dynamic range	58dB		gain = 1
Programmable Gain Range	- 1.5dB ± 6dB ± 2dB		in 4 steps
Responsivity at nominal gain	5,5DN/nJ/cm <sup>2</sup>		gain = 1
Responsivity max gain	11,5DN/nJ/cm <sup>2</sup>		gain = 3
Full well capacity	15Ke-		gain = 1
Full well capacity	6Ke-		gain = 3
DSNU	<0.4%		gain = 1
PRNU	<5%		gain = 1
Data output	10bit digital LVDS		
Supply Range	1.8V – 2.4V		
Frame rate	42Fps – 55Fps		Adjustable over power supply
Size (footprint)	1000µm x 1000µm	2200µm x 1000µm	
Number of pads	4	8	VDD, VSS Data+, Data-

Table 1: NanEye and NanEye Stereo Specifications



## 4. NanEye Power Consumption

The table below shows the NanEye power consumption.

Voltage (V)	Current (mA)	Power (mW)
1.8	1 to 2	3.6
2.1	2	4.2
2.4	3	7.2

*Table 2: NanEye Power Consumption*

## 5. Spectral Response

### 5.1 Relative Spectral Response

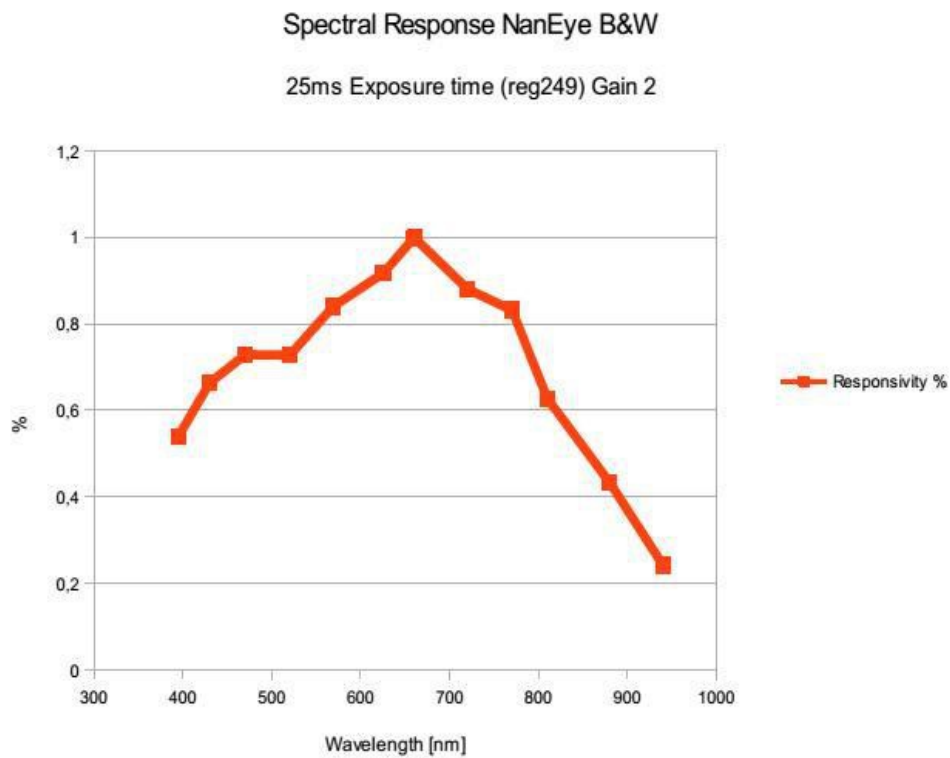

Figure 2: Relative Spectral Response

## 5.2 Color Matrix

The pixels are placed in a square matrix of 250x250 pixels. The Pixel matrix features a Bayer pattern colour filter array. The CFA and u-Lens shift are optimized for a chief ray angle (CRA) of the optics.

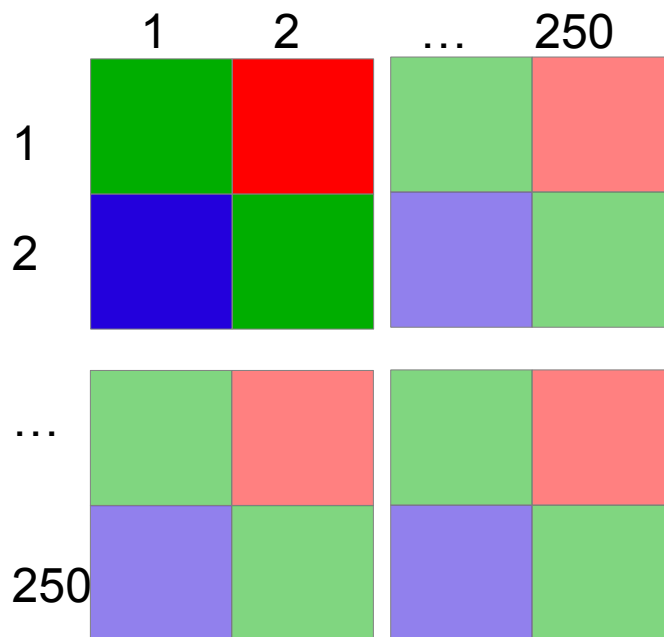

Figure 3: Coloured Versions Bayer Pattern Matrix

## 5.2.1 Filter transmission for RGB Bayer pattern sensor versions

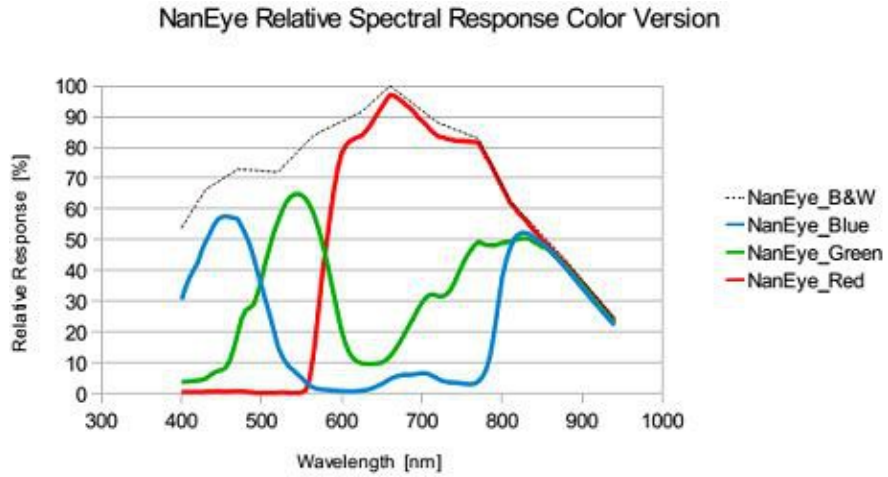

Figure 4: Filter Relative Responsivity

## 6. Frame Rate

### 6.1 Relation FPS vs Voltage

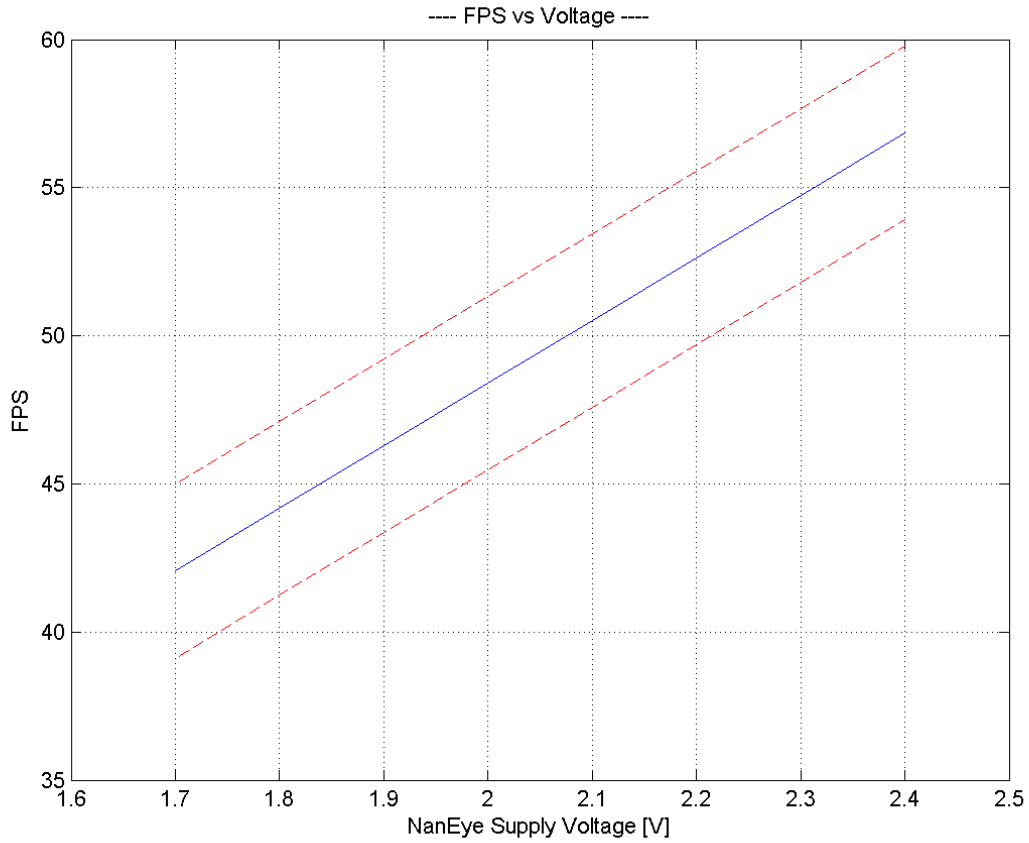

Figure 5: Relation between FPS and Voltage. Blue - typical, Red - max and min values

## 7. Cable Pinout

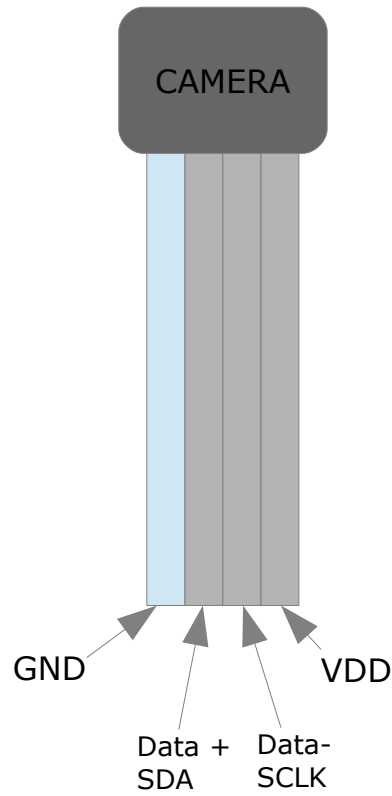

Figure 6: Identification of cable pin out for 4 cables (GND is normally colour marked)

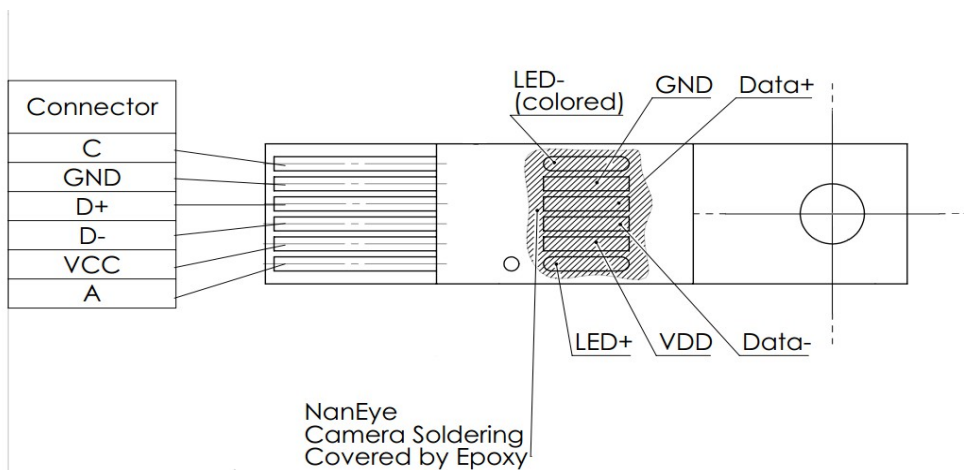

Figure 7: Identification of cable pin out for 6 cables (FLEX PCB connector)

## 8. Mechanical Dimensions

### 8.1 NanEye with Lens and Cable Soldered Dipped (Bended)

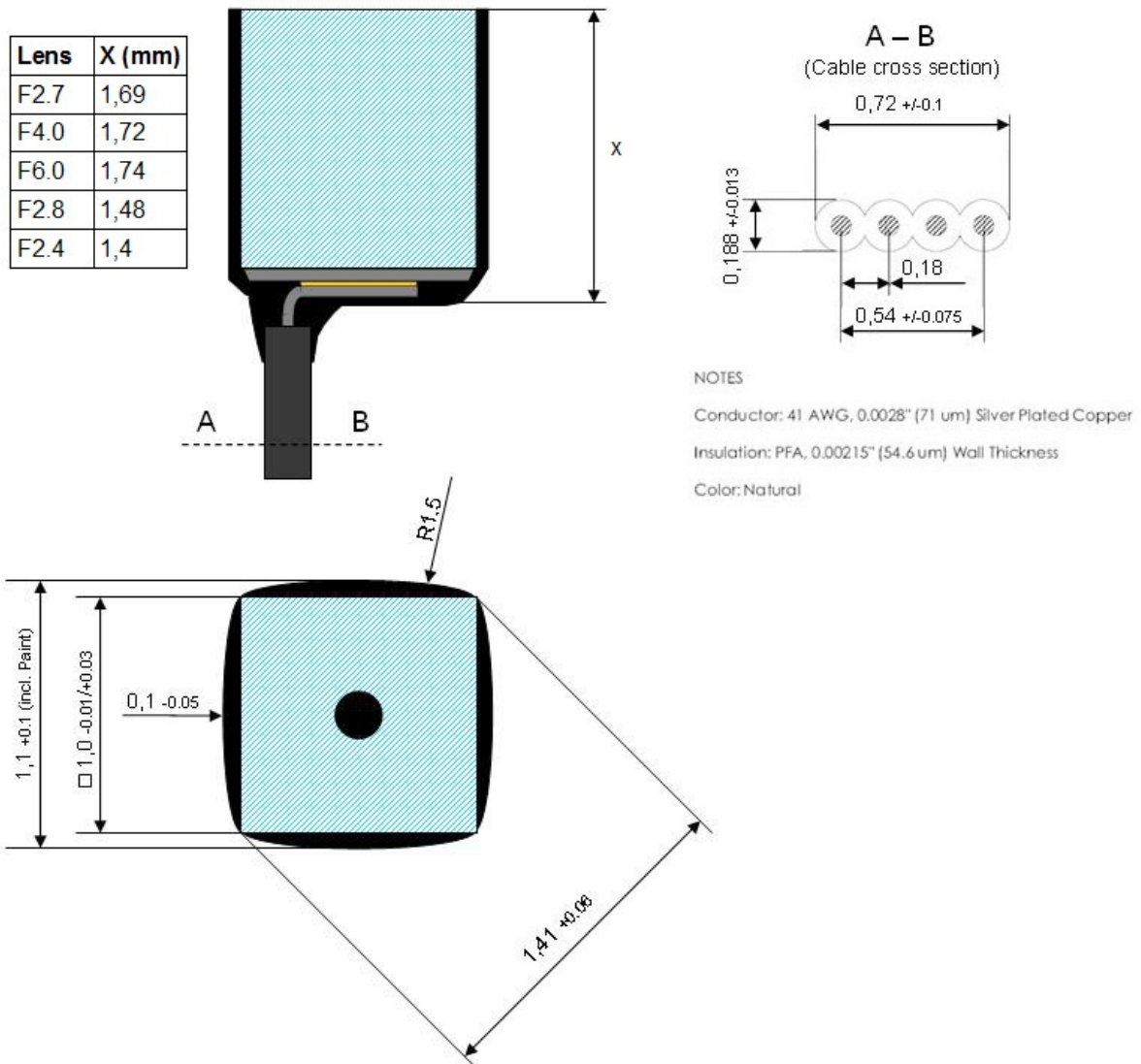

Figure 8: Measurements of the NANEYE module

## 8.2 NanEye with Lens and Cable Soldered Dipped 90° (Not Bended)

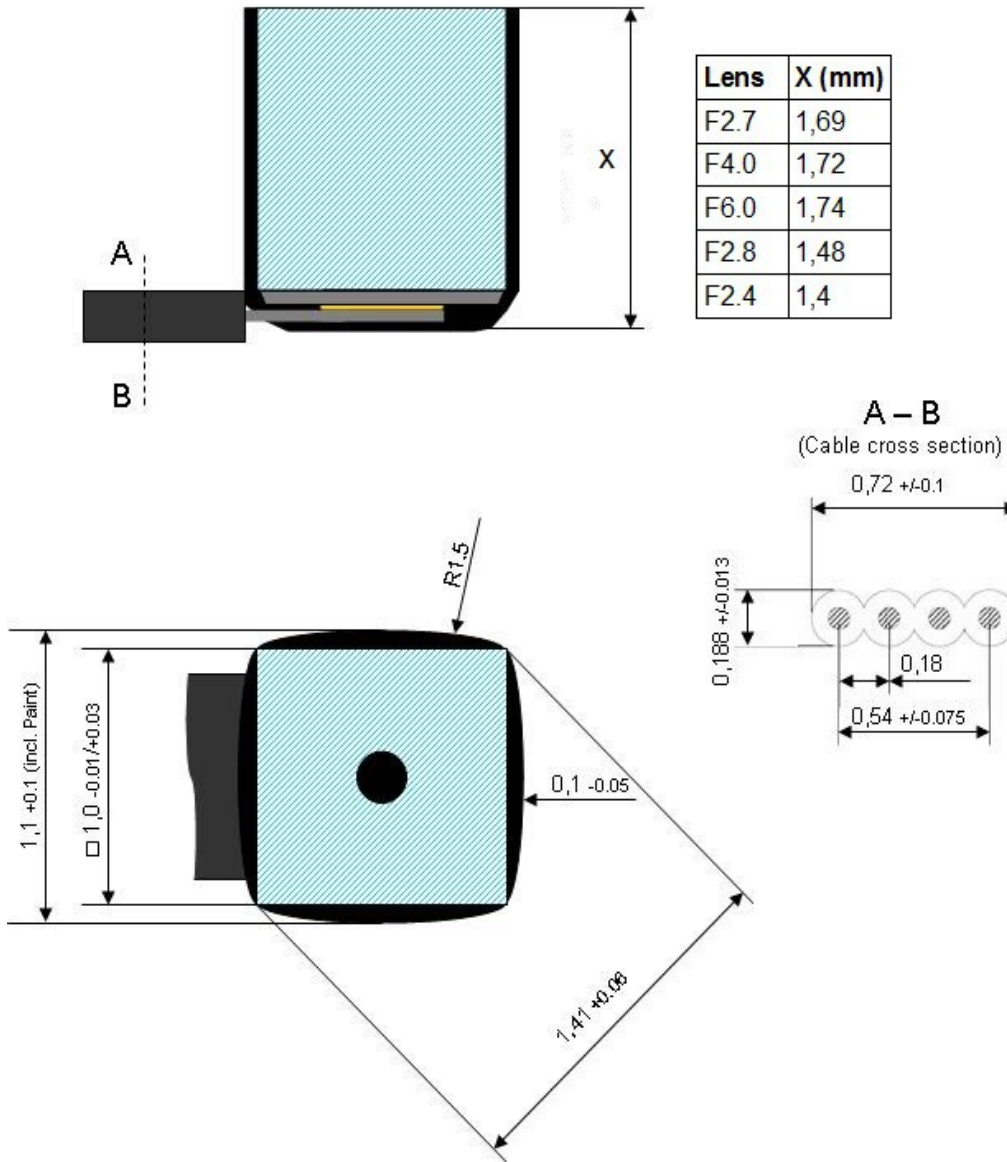
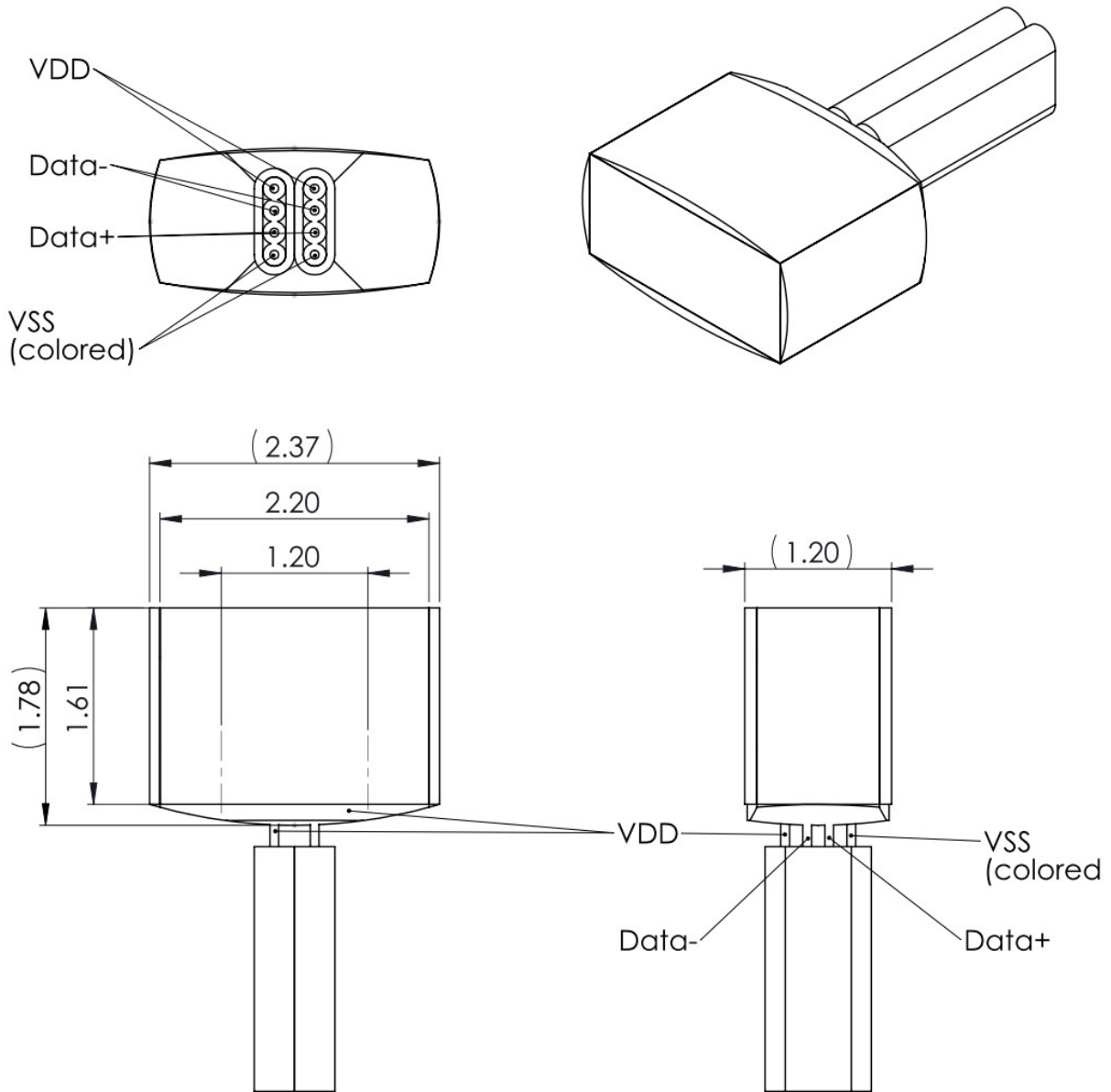

Figure 9: Measurements of the NANEYE module



**8.3 NanEye Stereo**



*Figure 10: Measurements of the NANEYE Stereo module (in mm)*

### 9. Optic

The optional optics available for the sensor is a high performance miniature lens module. It will be directly mounted on the image sensor and has its best focus position defined by design, so no mechanical set of focus is needed. The material is based on B33 (Borofloat glass). The design is made in such way that the surface towards the object is flat, so the lens performance is not influenced by the medium between the object and lens. Only the opening angle of the lens is reduced when the system operates in water.

## NanEye and NanEye Stereo Module

Different lens configurations are available.

	F#2.7 FOV90° <sup>■</sup>	F#4.0 FOV90°	F#6.0 FOV90°	F#2.8 FOV120°	F#4 FOV120°	F#2.4 FOV160°
F# Number	2.7	4.0	6.0	2.8	4	2.4
FOV (diagonal in air)	90° *	90°	90°	120°	120°	160°
FOV (diagonal in water)	62° *	62°	62°	86°	86°	95°
Max Distortion (diagonal in air)	23%	23%	23%	50%	50%	80%
Max Distortion (diagonal in water)	7.5%	7.5%	7.5%	16%	16%	20%
EFL (mm)	0.66	0.66	0.66	0.5	0.5	0.45
Aperture (um)	220	176	120	176	120	180
MTF @ Nyquist @ Center	25%	28%	30%	45%	45%	50%
MTF @ Nyquist @ 80% horizontal field	15%	18%	20%	15%	15%	12%
Best Focus (mm)	15	5	5	8	8	5
Depth of focus (mm)	5 – 40	3.5-30	3 – 50	4 – 40	3-50	4-50
Size (incl. image sensor, cover glass) (mm)	1 x 1 x 1.69 2.2 x 1.0 x 1.69 *	1 x 1 x 1.72	1 x 1 x 1.74	1 x 1 x 1.48	1 x 1 x 1.43	1 x 1 x 1.40

Table 1: Lens configuration

■ At the moment, we have available for NanEye Stereo the lens NanEye\_FOV90\_F2.7, \*two times for NanEye Stereo, \* For NanEye Stereo

The following image shows the CTF measures for different lens.

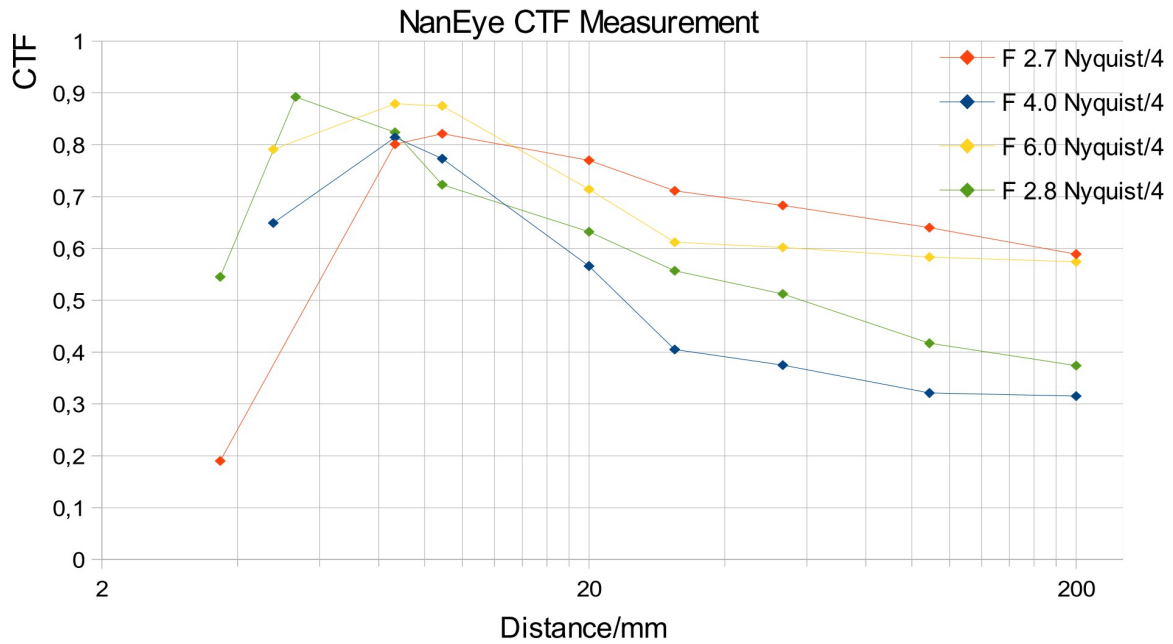

Figure 11: NanEye CTF measures

### 10. Package Options

#### 10.1 NanEye and NanEye Module

	Chip	Chip + Lens + Cable
<b>Colour</b>	B&W, RGB	B&W, RGB
<b>Package</b>	BGA	Chip + Lens + Cable
<b>Lens</b>	N/A	F#2.7 FOV 90°
		F#4.0 FOV 90°
		F#6.0 FOV 90°
		F#2.8 FOV 120°
		F#4.0 FOV 120°
		F#2.4 FOV 160°
<b>Cable Length</b>	N/A	15cm
		1m
		2m
		3m
<b>Cable Bend</b>	N/A	Bended
		Not Bended
<b>Sidewall Paint</b>	N/A	Painted
		Not Painted

*Table 3: Package Options for NanEye and NanEye Module*

### 10.2 NanEye Stereo Module

	Chip + Lens + Cable
<b>Colour</b>	B&W, RGB
<b>Lens</b>	FOV 90° F#2.7
<b>Cable Length</b>	2m
<b>Cable Bend</b>	Bended
<b>Sidewall Paint</b>	Black Painted

*Table 4: Package options for NanEye Stereo Module*

### 11. Miscellaneous

Optionally with the NanEye Module and NanEye Stereo Module, AWAIBA provides a base station and software to run the device on a PC in real-time with all necessary image corrections. The complete system consists of the module, the USB base station and the PC software.

## End of Document