

NOTE 1 Do not apply any excessive stress to the cable assembly position.
 2 We indicate the length of the harness on the last of product name, 'L' part.

Tolerance for [L]

Length L [mm]	Tolerance [mm]
50 ≦ L ≦ 200	±4
200 < L ≦ 500	±8
500 < L ≦ 1000	±12
1000 < L	±1.5%

Part No.	Cable color
~088N1T~	GRAY
~088N2T~	BLACK
~088N3T~	WHITE

3. Connector rotation angle is within ±45 degree from the above image.
 For long length in the case of L>500, the angle is optional.

4 Lock nut and tooth washer are attached separately in other package.

5. Specifications are subject to change without notice.

【 PRECAUTIONS FOR HANDLING 】

- ◆ Connector insertion and extraction
 - a. Connector shall be extracted vertically by specialised extraction JIG.
 Part No.: U-FL-LP-N-2<<CL Code:CL331-0494-5>>
 Never hold the cable when extracting the cable because it damages the connector.
 - b. Insert the connector as perpendicularly to the mating surface as possible by aligning the mating axes of both connectors. Do not excessively slant the connectors when inserting.
- ◆ Allowable loads on the cable after the connectors are mated.
 The figures below shot the maximum allowable loads on the cable. Do not apply loads exceeding these values to the cable.

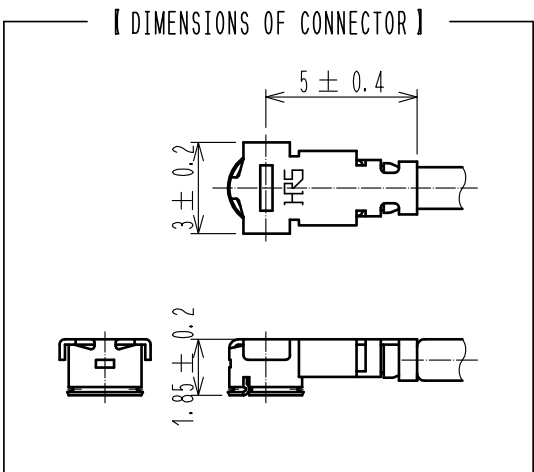

2	U.FL-LP-088HF(06)	CL331-0560-8-06			
1	HRM-200-088WBPJBN	CL323-0920-7-00	3	RF-MF50141 NISSEI ELECTRIC CO.,LTD.	
N o.	PART NO.	CODE NO.	N o.	PART NO.	MANUFACTURER

UNITS mm	SCALE FREE	COUNT	DESCRIPTION OF REVISIONS	DESIGNED	CHECKED	DATE
HR HIROSE ELECTRIC CO., LTD.			APPROVED :TO. KATAYAMA 20200721 CHECKED :TO. KATAYAMA 20200721 DESIGNED :MS. MATSUMOTO 20200721 DRAWN :MS. MATSUMOTO 20200721	DRAWING NO. HWBPJ-UFLHF6-088N*T-AL PART NO. CODE NO.		
						\triangle 1/1