

FEATURES

- $R_{DS(ON)} < 0.17\Omega @ V_{GS} = 10V$
- 100% avalanche tested
- RoHS compliant

MECHANICAL DATA

- Case: TO-220, ITO-220, TO-263, TO-247 package

Ordering Information

Part No.	Package Type	Package	Quality(box)
SJ22N65	TO-220	Tube	1000
SJ22N65F	ITO-220	Tube	1000
SJ22N65D	TO-263	Tape & Reel	800
SJ22N65P	TO-247	Tube	600

PRODUCT SUMMARY

$V_{DS}(V)$	$R_{DS(on)}(\Omega)_{Typ}$	$I_D(A)$
650	0.15@ $V_{GS} = 10V$	22

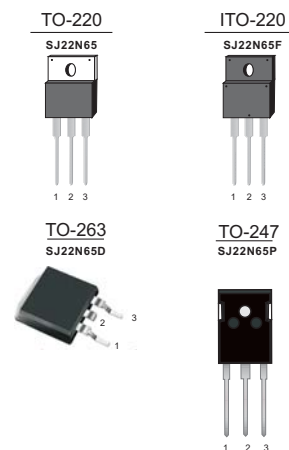

Block Diagram

Pin Definition:

1. Gate
2. Drain
3. Source

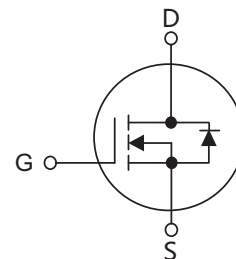

Table1 Absolute Maximum Ratings ($T_C = 25^\circ C$, unless otherwise specified)

Parameter	Symbol	TO-220/TO-263/TO-247	ITO-220	Unit
Drain-Source Voltage	V_{DS}	650		V
Gate-Source Voltage	V_{GS}	± 30		V
Continuous Drain Current	I_D	$T_C = 25^\circ C$	22	A
		$T_C = 100^\circ C$	13	
Pulsed Drain Current (Note 1)	I_{DM}	48		A
Single Pulse Avalanche Energy(Note 2)	E_{AS}	485		mJ
Avalanche Current(Note 1)	I_{AR}	3.5		A
Repetitive Avalanche Energy(Note 1)	E_{AR}	1		mJ
Peak Diode Recovery dv/dt (Note 3)	dv/dt	15		V/ns
Drain Source voltage slope($V_{DS} = 480V$)	dV_{DS}/dt	50		V/ns
Power Dissipation $T_C = 25^\circ C$	P_D	151	35	W
Operating Junction and Storage Temperature	T_J/T_{STG}	-55 ~ +150		$^\circ C$
Maximum Temperature for soldering	T_L	300		$^\circ C$

SJ22N65 Series

Table 2. Thermal Characteristics

Parameter	Symbol	TO-220/TO-263/TO-247	ITO-220	Unit
Thermal resistance Junction to Ambient	$R_{\theta JA}$	62	62	°C/W
Thermal resistance Junction to Case	$R_{\theta JC}$	0.82	3.57	°C/W

Table 3. Electrical Characteristics ($T_J=25^\circ\text{C}$, unless otherwise specified)

Parameter	Symbol	Test Conditions	Min	Typ	Max	Unit
Off Characteristics						
Drain-Source Breakdown Voltage	BV_{DSS}	$V_{GS}=0V, I_D=250\mu A$	650	--	--	V
Drain-Source Leakage Current	I_{DSS}	$V_{DS}=650V, V_{GS}=0V$	--	--	1	μA
Gate- Source Leakage Current	Forward	$V_{GS}=30V, V_{DS}=0V$	--	--	100	nA
	Reverse	$V_{GS}=-30V, V_{DS}=0V$	--	--	-100	nA
On Characteristics(Note 4)						
Gate Threshold Voltage	$V_{GS(TH)}$	$V_{DS}=V_{GS}, I_D=250\mu A$	2	--	4	V
Static Drain-Source On-State Resistance	$R_{DS(ON)}$	$V_{GS}=10V, I_D=11A$	--	0.15	0.17	Ω
Dynamic Characteristics(Note 5)						
Input Capacitance	C_{ISS}	$V_{DS}=25V, V_{GS}=0V, f=1\text{MHz}$	--	1510	--	pF
Output Capacitance	C_{OSS}		--	75	--	pF
Reverse Transfer Capacitance	C_{RSS}		--	6	--	pF
Switching Characteristics (Note 5)						
Turn-On Delay Time	$t_d(\text{on})$	$V_{DD}=520V, I_D=11A,$ $R_G=20\Omega$	--	25	--	ns
Turn-On Rise Time	t_R		--	17	--	ns
Turn-Off Delay Time	$t_d(\text{off})$		--	130	--	ns
Turn-Off Fall Time	t_f		--	11	--	ns
Total Gate Charge	Q_G	$V_{DS}=520V, I_D=11A,$ $V_{GS}=10V$	--	90	--	nC
Gate-Source Charge	Q_{GS}		--	8.5	--	nC
Gate-Drain Charge	Q_{GD}		--	13	--	nC
Drain-Source Diode Characteristics and Maximum Ratings						
Drain-Source Diode Forward Voltage	V_{SD}	$V_{GS}=0V, I_S=11A$	--	0.9	1.5	V
Maximum Continuous Drain-Source Diode Forward Current	I_S		--	--	22	A
Reverse Recovery Time	t_{rr}	$V_{GS}=0V, I_F=11A$	--	475	--	ns
Reverse Recovery Charge	Q_{RR}	$di/dt=100A/\mu s$ (Note 1)	--	5800	--	nC

Notes : 1 Repetitive Rating: Pulse width limited by maximum junction temperature

2 $L=60\text{mH}, I_{AS}=3A, V_{DD}=150V$, Starting $T_J=25^\circ\text{C}$

3 $I_{SD}\leq 4.5A, di/dt\leq 200A/\mu s, V_{DD}\leq BV_{DSS}$, Starting $T_J=25^\circ\text{C}$

4 Pulse Test: Pulse width $\leq 300\mu s$, Duty cycle $\leq 2\%$

5 Guaranteed by design, not subject to production

Typical characteristics Diagrams

<p>Power dissipation Non FullPAK</p>	<p>Power dissipation FullPAK</p>
<p>$P_{tot} = f(T_c)$</p>	<p>$P_{tot} = f(T_c)$</p>
<p>Max. transient thermal impedance Non FullPAK</p>	<p>Max. transient thermal impedance FullPAK</p>
<p>$Z_{(thjC)} = f(t_p)$; parameter: $D = t_p/T$</p>	<p>$Z_{(thjC)} = f(t_p)$; parameter: $D = t_p/T$</p>

SJ22N65 Series

Typical characteristics Diagrams

Power dissipation
TO-220, TO-247, TO-262, TO-263

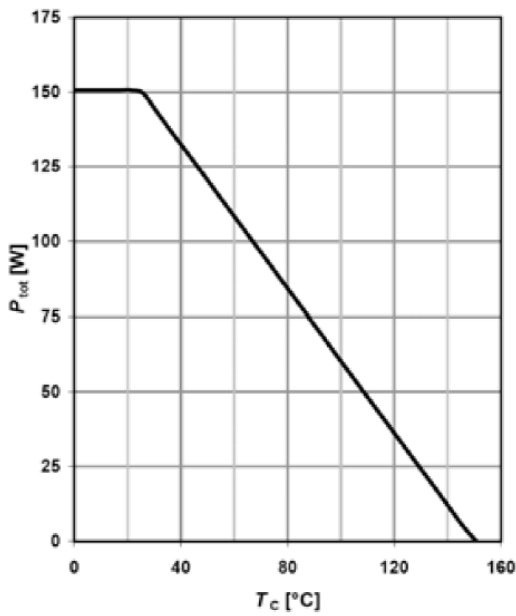

$$P_{tot} = f(T_c)$$

Power dissipation
TO-220 FullPAK

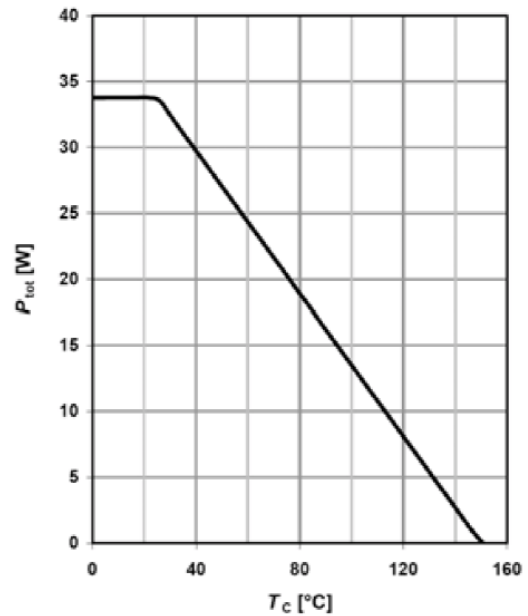

$$P_{tot} = f(T_c)$$

Max. transient thermal impedance
TO-220, TO-247, TO-262, TO-263

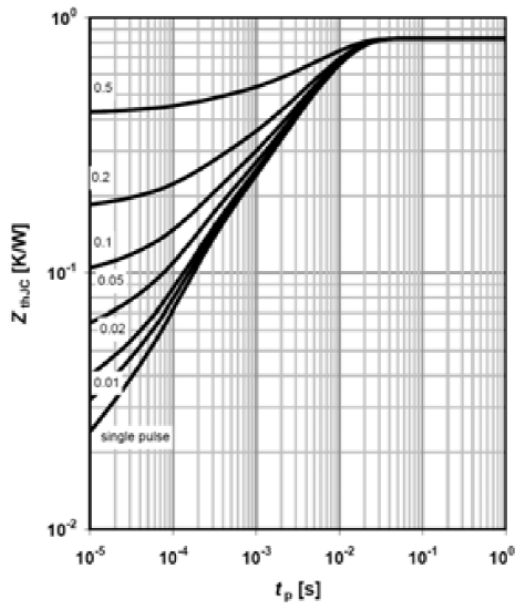

$$Z_{(thJC)} = f(t_p); \text{ parameter: } D = t_p/T$$

Max. transient thermal impedance
TO-220 FullPAK

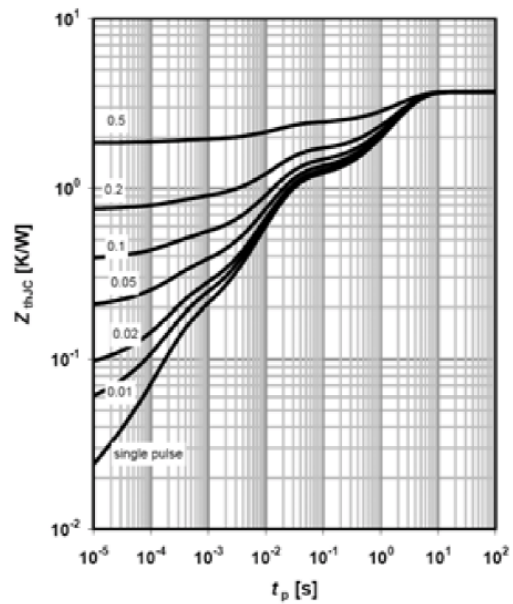

$$Z_{(thJC)} = f(t_p); \text{ parameter: } D = t_p/T$$

SJ22N65 Series

Typical characteristics Diagrams

Safe operating area $T_C=25\text{ }^\circ\text{C}$
TO-220, TO-247, TO-262, TO-263

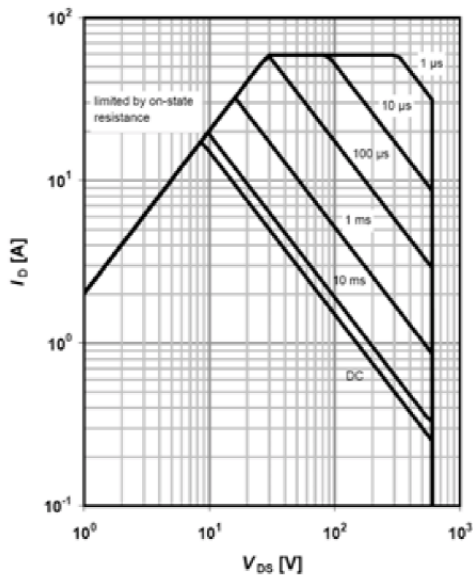

$I_D=f(V_{DS}); T_C=25\text{ }^\circ\text{C}; D=0$; parameter t_p

Safe operating area $T_C=25\text{ }^\circ\text{C}$
TO-220 FullPAK

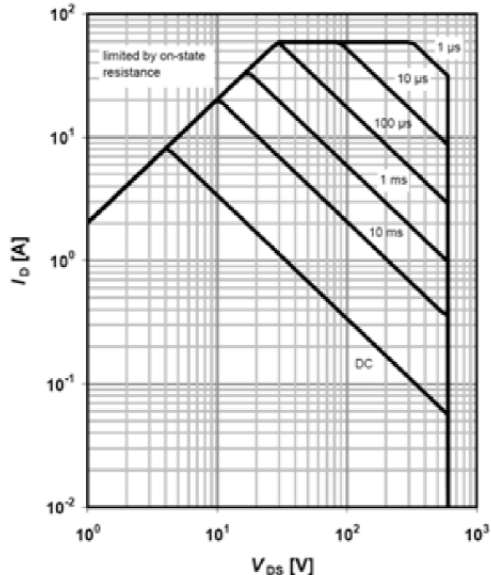

$I_D=f(V_{DS}); T_C=25\text{ }^\circ\text{C}; D=0$; parameter t_p

Safe operating area $T_C=80\text{ }^\circ\text{C}$
TO-220, TO-247, TO-262, TO-263

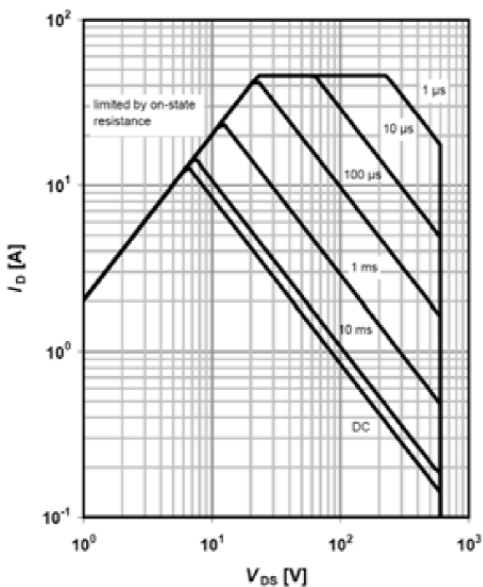

$I_D=f(V_{DS}); T_C=80\text{ }^\circ\text{C}; D=0$; parameter t_p

Safe operating area $T_C=80\text{ }^\circ\text{C}$
TO-220 FullPAK

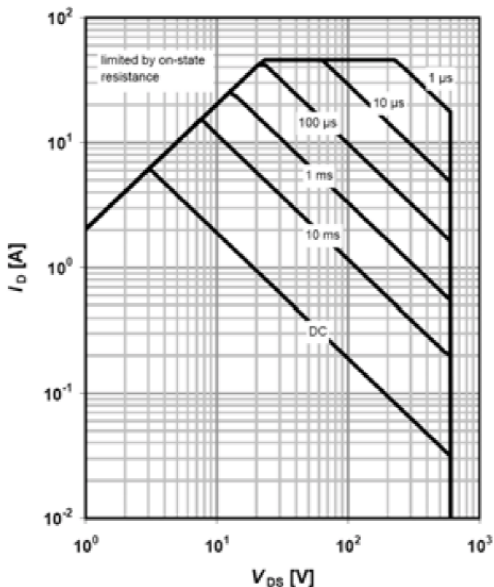

$I_D=f(V_{DS}); T_C=80\text{ }^\circ\text{C}; D=0$; parameter t_p

Typical characteristics Diagrams

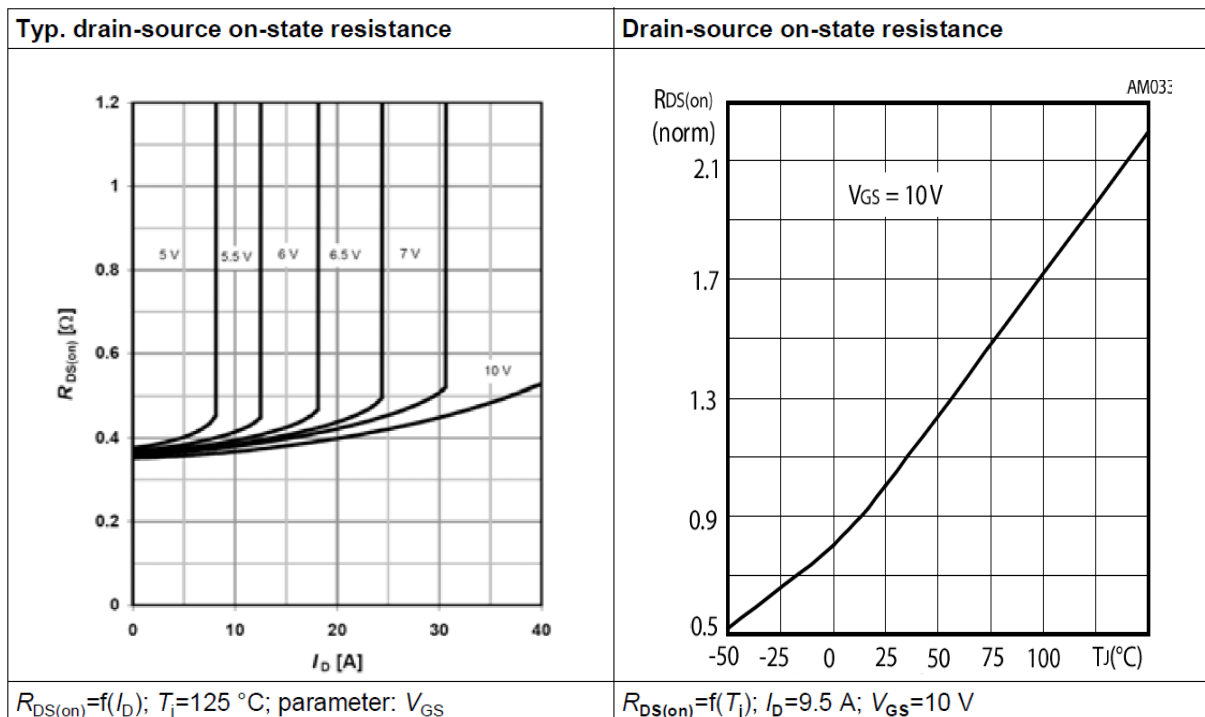
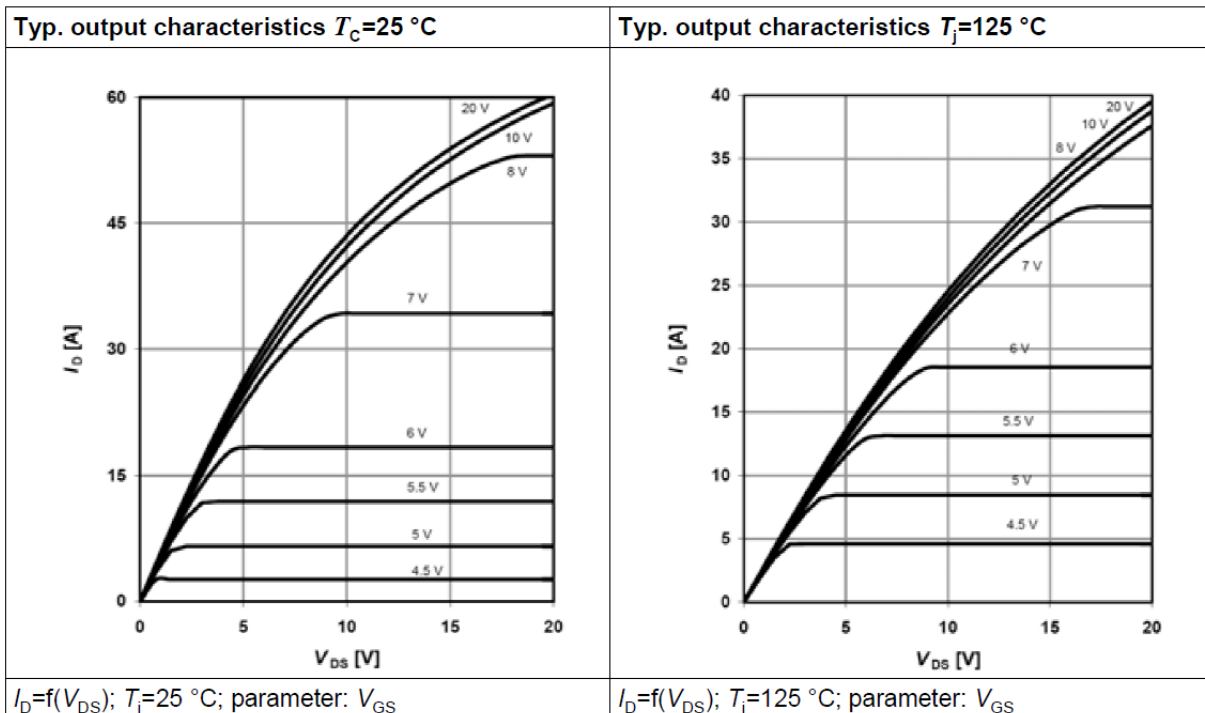

SJ22N65 Series

Typical characteristics Diagrams

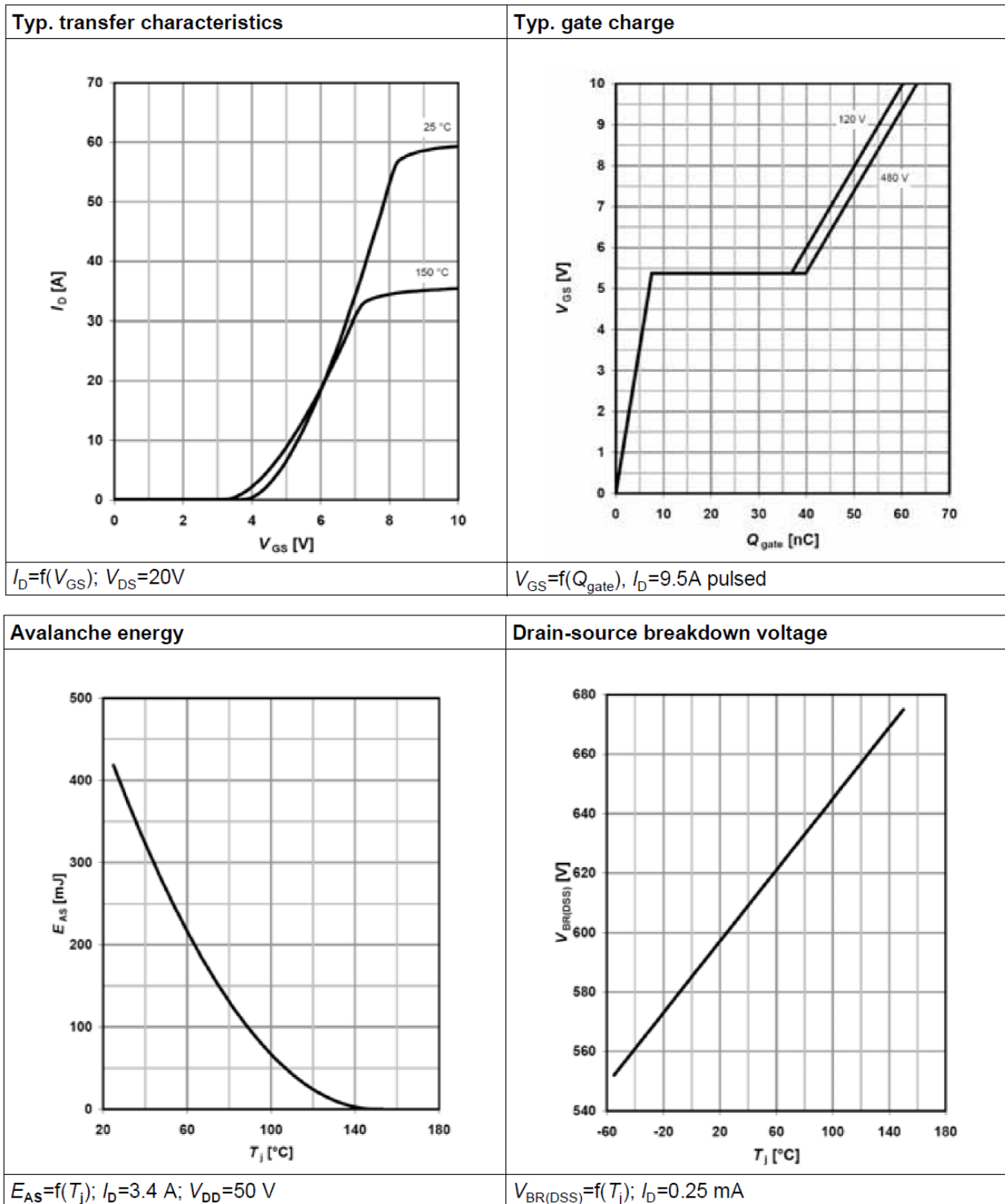

TYPICAL TEST CIRCUIT

Table 20 Switching times test circuit and waveform for inductive load

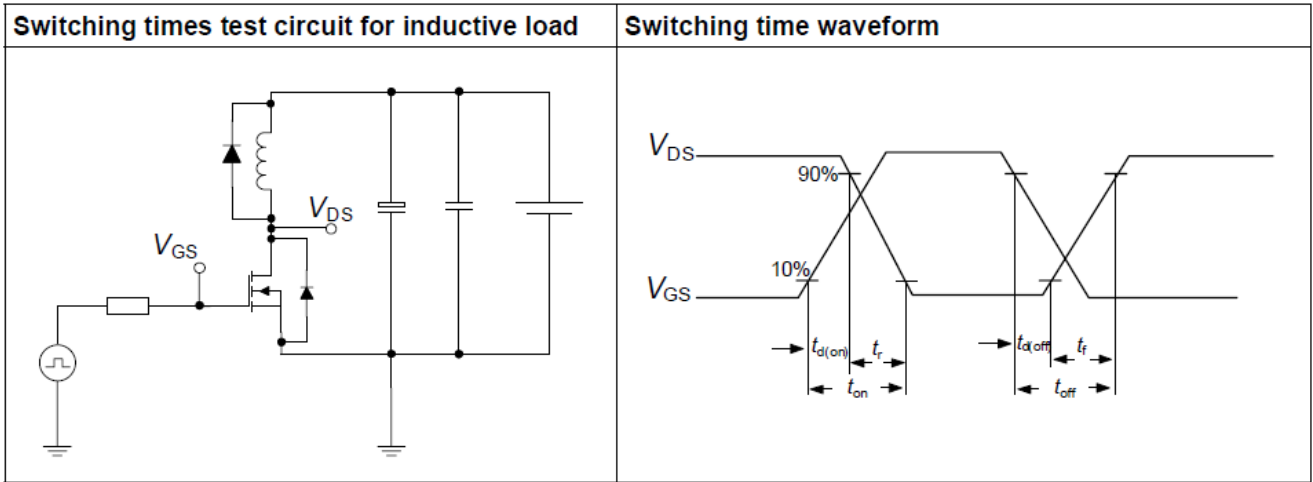

Table 21 Unclamped inductive load test circuit and waveform

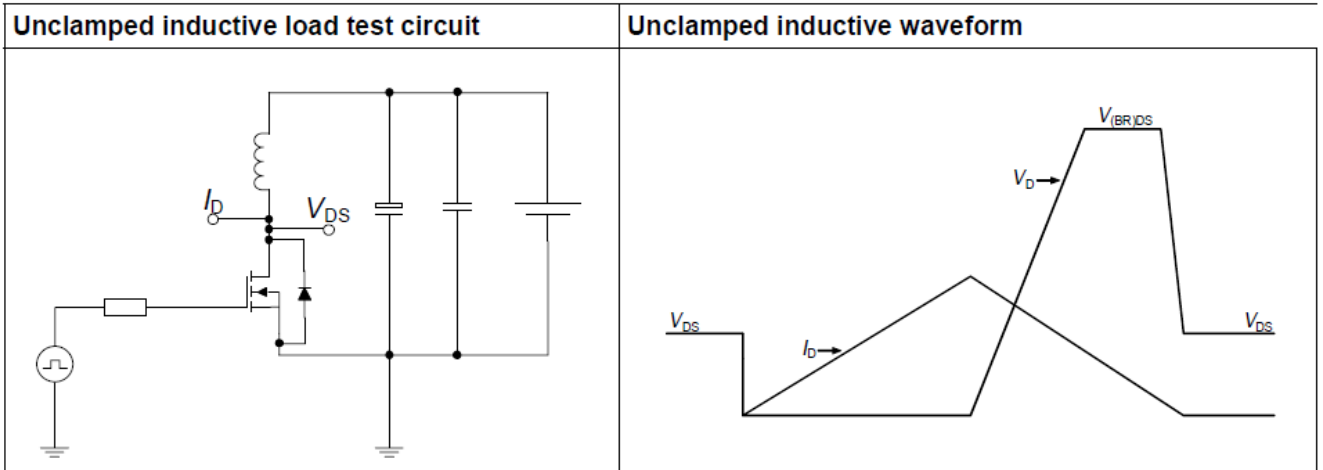
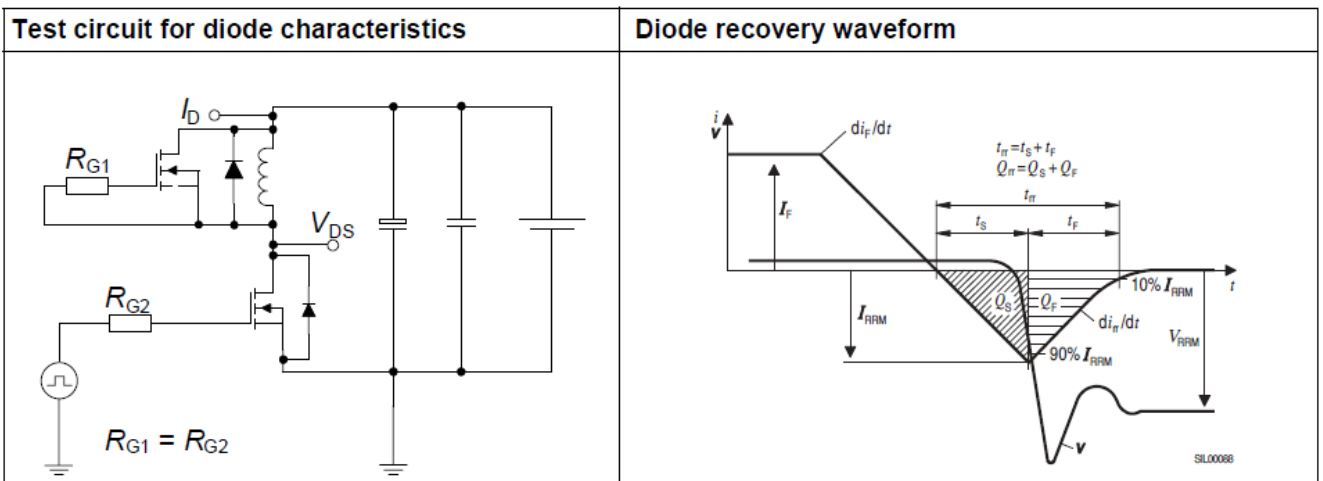
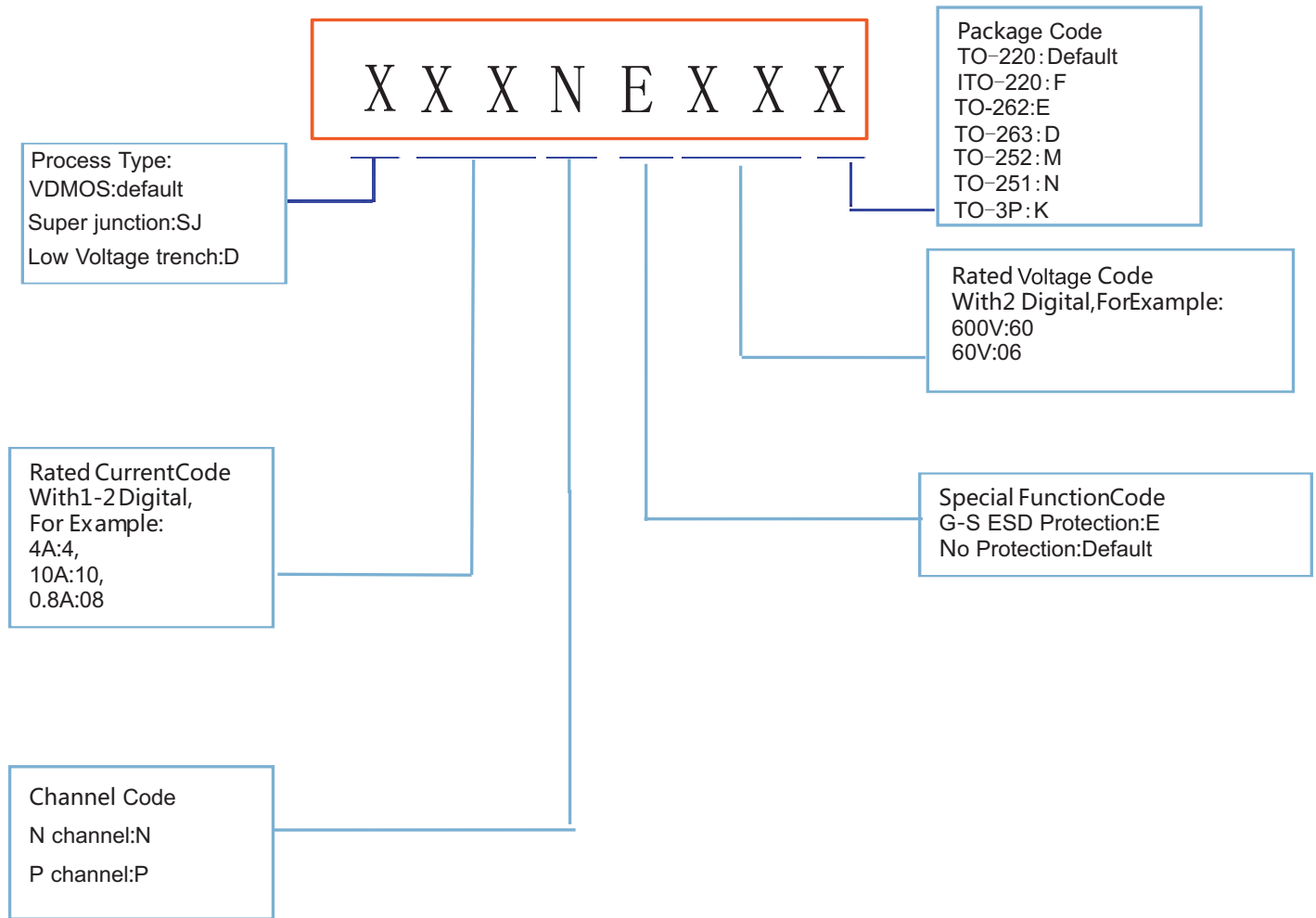

Table 22 Test circuit and waveform for diode characteristics



Product Names Rules



SJ22N65 Series

Dimensions

TO-220 PACKAGE OUTLINE DIMENSIONS

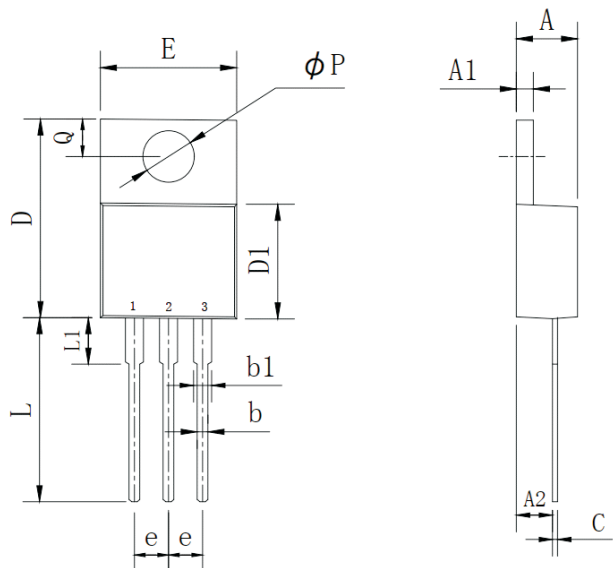

Symbol	Dimensions In Millimeters		Dimensions In Inches	
	MIN	MAX	MIN	MAX
A	4.25	4.87	0.167	0.192
A1	1.07	1.47	0.042	0.058
A2	2.03	2.92	0.080	0.115
b	0.51	1.11	0.020	0.044
b1	0.97	1.6	0.038	0.063
C	0.3	0.7	0.012	0.028
D	14.6	15.9	0.575	0.626
D1	8.04	9.3	0.317	0.366
E	9.57	10.57	0.377	0.416
e	2.34	2.74	0.092	0.108
L	12.58	14.3	0.495	0.563
L1	2.8	4.2	0.110	0.165
P	3.4	4.14	0.134	0.163
Q	2.45	3	0.096	0.118

ITO-220 PACKAGE OUTLINE DIMENSIONS

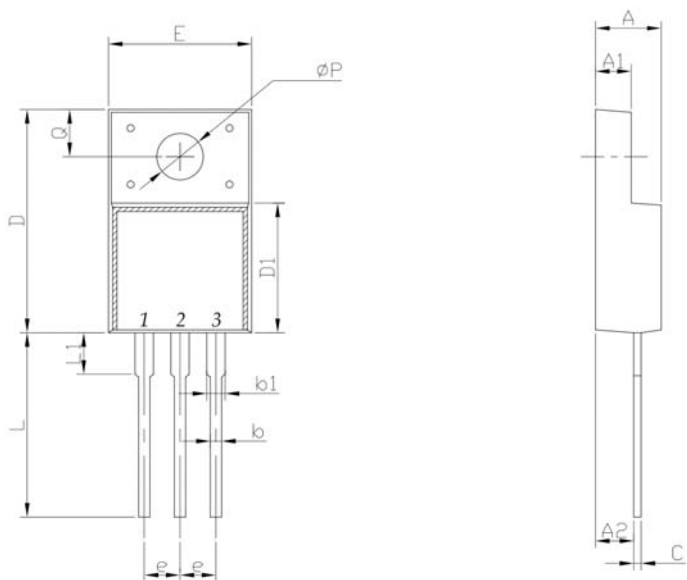

Symbol	Dimensions In Millimeters		Dimensions In Inches	
	MIN	MAX	MIN	MAX
A	4.24	4.9	0.167	0.193
A1	2.3	2.92	0.091	0.115
A2	2.61	2.81	0.103	0.111
b	0.3	1	0.012	0.039
b1	0.9	1.55	0.035	0.061
C	0.3	0.7	0.012	0.028
D	14.5	16.36	0.571	0.644
D1	8.8	9.41	0.346	0.370
E	9.5	10.5	0.374	0.413
e	2.3	2.75	0.091	0.108
L	12.6	14	0.496	0.551
L1	2.45	4.3	0.096	0.169
P	2.9	3.8	0.114	0.150
Q	2.5	3.55	0.098	0.140

SJ22N65 Series

Dimensions

TO-263 PACKAGE OUTLINE DIMENSIONS

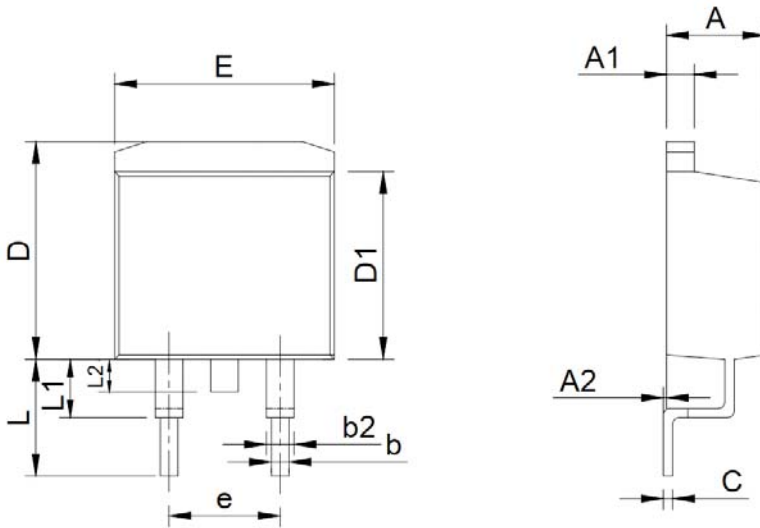

Symbol	Dimensions In Millimeters		Dimensions In Inches	
	MIN	MAX	MIN	MAX
A	4.25	4.87	0.167	0.192
A1	1.07	1.47	0.042	0.058
A2	0	0.25	0.000	0.010
b	0.61	1.01	0.024	0.040
b1	1.2	1.34	0.047	0.053
C	0.3	0.6	0.012	0.024
D	9.48	10.84	0.373	0.427
D1	8.49	9.3	0.334	0.366
E	9.7	10.31	0.382	0.406
e	4.88	5.28	0.192	0.208
L	4.46	5.85	0.176	0.230
L1	1.33	2.33	0.052	0.092
L2	0	2.2	0.000	0.087

TO-247 PACKAGE OUTLINE DIMENSIONS

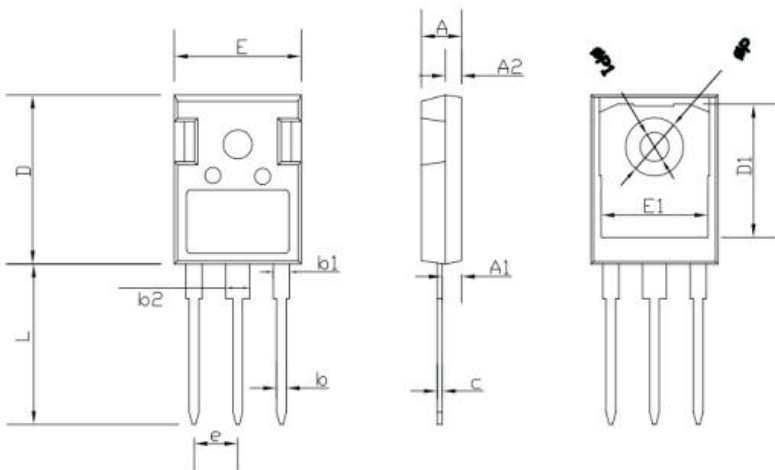

Symbol	Dimensions In Millimeters		Dimensions In Inches	
	min.	max.	min.	max.
A	4.90	5.10	0.193	0.201
A1	2.31	2.51	0.091	0.099
A2	1.90	2.10	0.075	0.083
b	1.16	1.26	0.046	0.050
b1	1.96	2.06	0.0772	0.0812
b2	2.96	3.06	0.117	0.121
c	0.59	0.66	0.0232	0.0260
D	20.90	21.10	0.8235	0.8313
D1	16.25	16.85	0.6403	0.6639
E	15.70	15.90	0.6186	0.6265
E1	13.10	13.50	0.5161	0.5319
e	5.44		0.2143	
L	19.80	20.10	0.7801	0.7919
ΦP	3.50	3.70	0.1379	0.1458
ΦP1	0	7.30	0	0.2876

Friendship Reminder

■ JiNan JingHeng (hereinafter referred to as JH) reserves the right to make changes to this document and its products and specifications at anytime without notice.

■ Customers should obtain and confirm the latest product information and specifications before final design, purchase or use.

■ JH makes no warranty, representation or guarantee regarding the suitability of its products for any particular purpose, nor does JH assume any liability for application assistance or customer product design.

■ JH does not warrant or accept any liability with products which are purchased or used for any unintended or unauthorized application.

■ No license is granted by implication or otherwise under any intellectual property rights of JH.

■ JH's products are not authorized for use as critical components in life support devices or systems without express written approval of JH.