



**Working Voltage: 5.0 to 440 V**

**Peak Pulse Power: 400 W**

### Features

- Glass passivated chip
- 400 W peak pulse power capability with a 10/1000  $\mu$ s waveform, repetitive rate (duty cycle):0.01 %
- Low leakage
- Uni and Bidirectional unit
- Excellent clamping capability
- Very fast response time

### Mechanical Data

- Case: Molded plastic
- Epoxy: UL 94V-0 rate flame retardant
- Lead: Solderable per MIL-STD-750, method 2026
- Polarity: Color band denotes cathode end except Bipolar
- Mounting position: Any
- Moisture Sensitivity Level 1

### SMA (DO-214AC)

(Cathode band Only Uui-polarity product)

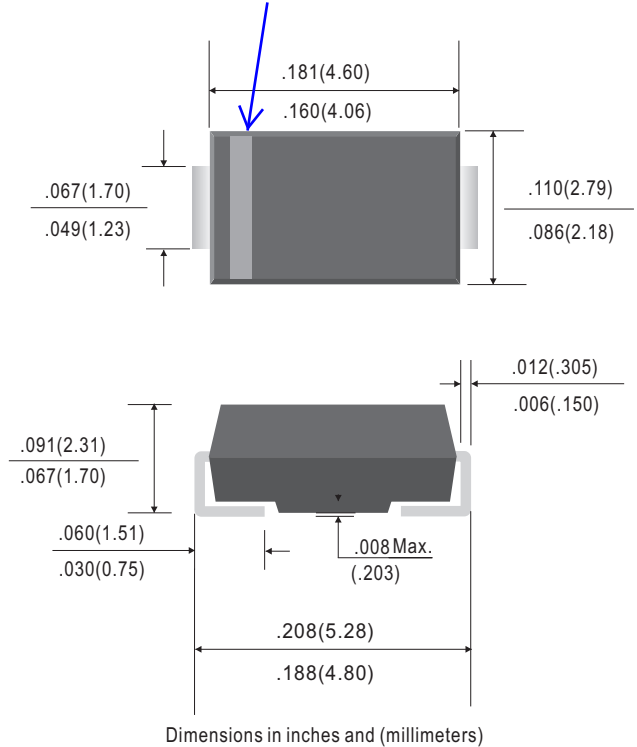

### Maximum Ratings( $T_A=25^{\circ}\text{C}$ unless otherwise noted)

Parameter	Symbol	Value	UNIT
Peak power dissipation with a 10/1000 $\mu$ s waveform <sup>(1)</sup>	$P_{PP}$	400	W
Peak pulse current with a 10/1000 $\mu$ s waveform <sup>(1)</sup>	$I_{PP}$	See Next Table	A
Power dissipation on infinite heatsink at $T_L = 75^{\circ}\text{C}$	$P_D$	1.0	W
Peak forward surge current, 8.3 ms single half sine-wave unidirectional only <sup>(2)</sup>	$I_{FSM}$	40	A
Maximum instantaneous forward voltage at 25 A for unidirectional only <sup>(3)</sup>	$V_F$	3.5/5.0	V
Operating junction and storage temperature range	$T_J, T_{STG}$	-55 to +150	$^{\circ}\text{C}$

Note:

(1) Non-repetitive current pulse per Fig.5 and derated above  $T_A = 25^{\circ}\text{C}$  per Fig.1

(2) Measured on 8.3 ms single half sine-wave or equivalent square wave, duty cycle = 4 pulses per minute maximum.

(3)  $V_F < 3.5\text{V}$  for devices of  $V_{BR} < 200\text{V}$  and  $V_F < 5.0\text{V}$  for devices of  $V_{BR} > 201\text{V}$

**Ratings and Characteristics Curves ( $T_A=25^{\circ}\text{C}$  unless otherwise noted)**

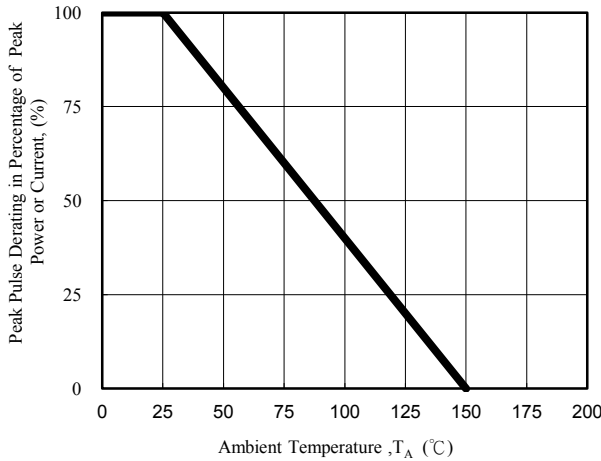

Fig. 1 - Pulse Derating Curve

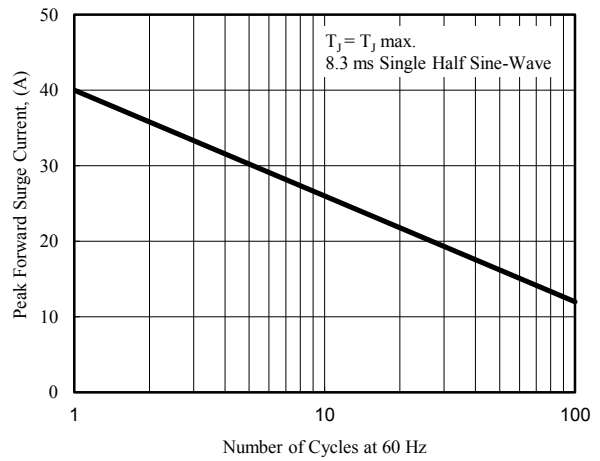

Fig. 2 - Maximum Non-Repetitive Surge Current

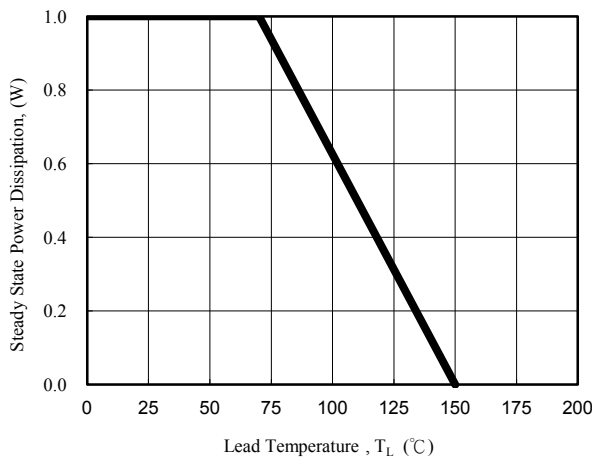

Fig. 3 - Steady State Power Derating Curve

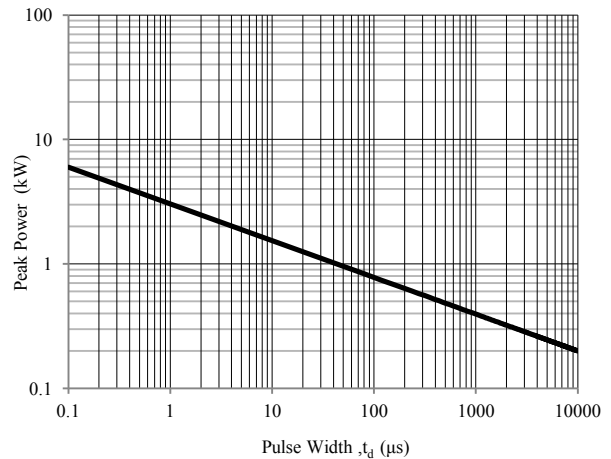

Fig. 4 - Peak Pulse Power Rating Curve

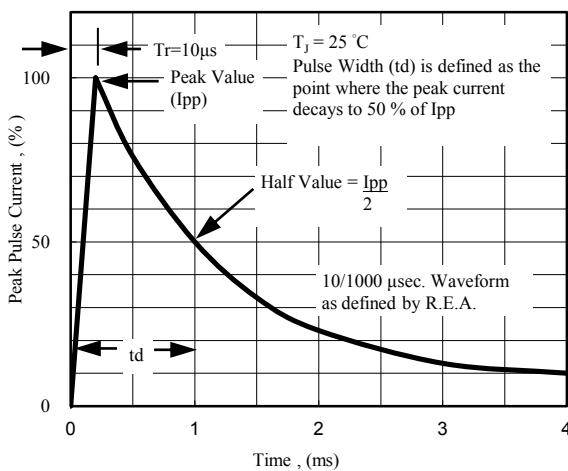

Fig. 5 - Pulse Waveform

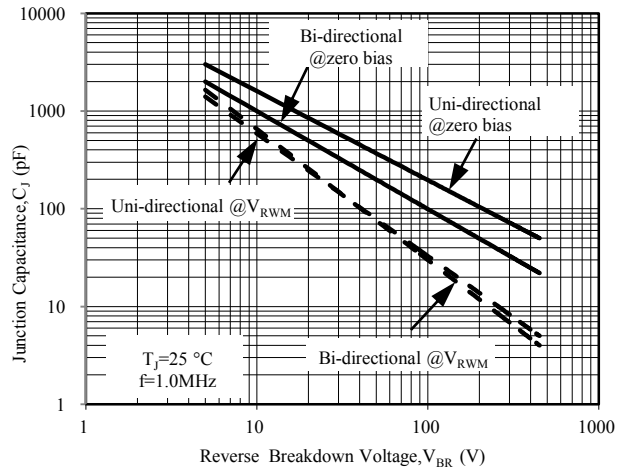

Fig. 6 - Typical Junction Capacitance



## 400W SURFACE MOUNT TRANSIENT VOLTAGE SUPPRESSOR SMA(DO-214AC) PACKAGE

## SMAJ Series

Part No.		Marking Code		Reverse Stand-Off Voltage $V_{RWM}$ (V)	Breakdown Voltage $V_{BR}$ (V) Min @ $I_T$	Breakdown Voltage $V_{BR}$ (V) Max @ $I_T$	Test Current $I_T$ (mA)	Max Clamping Voltage $V_C$ (V) @ $I_{PP}$	Peak Pulse Current $I_{PP}$ (A)	Reverse Leakage $I_R$ ( $\mu$ A) @ $V_{RWM}$
UNI-POLAR	BI-POLAR	UNI-POLAR	BI-POLAR							
SMAJ5.0A	SMAJ5.0CA	AE	WE	5.0	6.40	7.00	10	9.2	43.48	800
SMAJ6.0A	SMAJ6.0CA	AG	WG	6.0	6.67	7.37	10	10.3	38.83	800
SMAJ6.5A	SMAJ6.5CA	AK	WK	6.5	7.22	7.98	10	11.2	35.71	500
SMAJ7.0A	SMAJ7.0CA	AM	WM	7.0	7.78	8.60	10	12.0	33.33	200
SMAJ7.5A	SMAJ7.5CA	AP	WP	7.5	8.33	9.21	1	12.9	31.01	100
SMAJ8.0A	SMAJ8.0CA	AR	WR	8.0	8.89	9.83	1	13.6	29.41	50
SMAJ8.5A	SMAJ8.5CA	AT	WT	8.5	9.44	10.40	1	14.4	27.78	10
SMAJ9.0A	SMAJ9.0CA	AV	WV	9.0	10.00	11.10	1	15.4	25.97	5
SMAJ10A	SMAJ10CA	AX	WX	10.0	11.10	12.30	1	17.0	23.53	5
SMAJ11A	SMAJ11CA	AZ	WZ	11.0	12.20	13.50	1	18.2	21.98	5
SMAJ12A	SMAJ12CA	BE	XE	12.0	13.30	14.70	1	19.9	20.10	5
SMAJ13A	SMAJ13CA	BG	XG	13.0	14.40	15.90	1	21.5	18.60	5
SMAJ14A	SMAJ14CA	BK	XK	14.0	15.60	17.20	1	23.2	17.24	5
SMAJ15A	SMAJ15CA	BM	XM	15.0	16.70	18.50	1	24.4	16.39	5
SMAJ16A	SMAJ16CA	BP	XP	16.0	17.80	19.70	1	26.0	15.38	5
SMAJ17A	SMAJ17CA	BR	XR	17.0	18.90	20.90	1	27.6	14.49	5
SMAJ18A	SMAJ18CA	BT	XT	18.0	20.00	22.10	1	29.2	13.70	5
SMAJ19A	SMAJ19CA	BB	XB	19.0	21.10	23.30	1	30.8	13.00	5
SMAJ20A	SMAJ20CA	BV	XV	20.0	22.20	24.50	1	32.4	12.35	5
SMAJ22A	SMAJ22CA	BX	XX	22.0	24.40	26.90	1	35.5	11.27	5
SMAJ24A	SMAJ24CA	BZ	XZ	24.0	26.70	29.50	1	38.9	10.28	5
SMAJ26A	SMAJ26CA	CE	YE	26.0	28.90	31.90	1	42.1	9.50	5
SMAJ28A	SMAJ28CA	CG	YG	28.0	31.10	34.40	1	45.4	8.81	5
SMAJ30A	SMAJ30CA	CK	YK	30.0	33.30	36.80	1	48.4	8.26	5
SMAJ33A	SMAJ33CA	CM	YM	33.0	36.70	40.60	1	53.3	7.50	5
SMAJ36A	SMAJ36CA	CP	YP	36.0	40.00	44.20	1	58.1	6.88	5
SMAJ40A	SMAJ40CA	CR	YR	40.0	44.40	49.10	1	64.5	6.20	5
SMAJ43A	SMAJ43CA	CT	YT	43.0	47.80	52.80	1	69.4	5.76	5
SMAJ45A	SMAJ45CA	CV	YV	45.0	50.00	55.30	1	72.7	5.50	5
SMAJ48A	SMAJ48CA	CX	YX	48.0	53.30	58.90	1	77.4	5.17	5
SMAJ51A	SMAJ51CA	CZ	YZ	51.0	56.70	62.70	1	82.4	4.85	5
SMAJ54A	SMAJ54CA	RE	ZE	54.0	60.00	66.30	1	87.1	4.59	5
SMAJ58A	SMAJ58CA	RG	ZG	58.0	64.40	71.20	1	93.6	4.27	5
SMAJ60A	SMAJ60CA	RK	ZK	60.0	66.70	73.70	1	96.8	4.13	5
SMAJ64A	SMAJ64CA	RM	ZM	64.0	71.10	78.60	1	103.0	3.88	5
SMAJ70A	SMAJ70CA	RP	ZP	70.0	77.80	86.00	1	113.0	3.54	5
SMAJ75A	SMAJ75CA	RR	ZR	75.0	83.30	92.10	1	121.0	3.31	5
SMAJ78A	SMAJ78CA	RT	ZT	78.0	86.70	95.80	1	126.0	3.17	5
SMAJ80A	SMAJ80CA	RB	ZB	80.0	88.80	97.60	1	129.6	3.09	5



## 400W SURFACE MOUNT TRANSIENT VOLTAGE SUPPRESSOR SMA(DO-214AC) PACKAGE

## SMAJ Series

Part No.		Marking Code		Reverse Stand-Off Voltage $V_{RWM}$ (V)	Breakdown Voltage $V_{BR}$ (V) Min @ $I_T$	Breakdown Voltage $V_{BR}$ (V) Max @ $I_T$	Test Current $I_T$ (mA)	Max Clamping Voltage $V_C$ (V) @ $I_{PP}$	Peak Pulse Current $I_{PP}$ (A)	Reverse Leakage $I_R$ ( $\mu$ A) @ $V_{RWM}$
UNI-POLAR	BI-POLAR	UNI-POLAR	BI-POLAR							
SMAJ85A	SMAJ85CA	RV	ZV	85.0	94.40	104.00	1	137.0	2.92	5
SMAJ90A	SMAJ90CA	RX	ZX	90.0	100.00	111.00	1	146.0	2.74	5
SMAJ100A	SMAJ100CA	RZ	ZZ	100.0	111.00	123.00	1	162.0	2.47	5
SMAJ110A	SMAJ110CA	SE	VE	110.0	122.00	135.00	1	177.0	2.26	5
SMAJ120A	SMAJ120CA	SG	VG	120.0	133.00	147.00	1	193.0	2.07	5
SMAJ130A	SMAJ130CA	SK	VK	130.0	144.00	159.00	1	209.0	1.91	5
SMAJ140A	SMAJ140CA	SB	VB	140.0	155.00	171.00	1	226.8	1.76	5
SMAJ150A	SMAJ150CA	SM	VM	150.0	167.00	185.00	1	243.0	1.65	5
SMAJ160A	SMAJ160CA	SP	VP	160.0	178.00	197.00	1	259.0	1.54	5
SMAJ170A	SMAJ170CA	SR	VR	170.0	189.00	209.00	1	275.0	1.45	5
SMAJ180A	SMAJ180CA	ST	VT	180.0	200.00	220.00	1	291.6	1.37	5
SMAJ190A	SMAJ190CA	SW	VW	190.0	211.00	232.00	1	307.8	1.30	5
SMAJ200A	SMAJ200CA	SV	VV	200.0	224.00	247.00	1	324.0	1.23	5
SMAJ220A	SMAJ220CA	SX	VX	220.0	246.00	272.00	1	356.0	1.12	5
SMAJ250A	SMAJ250CA	SZ	VZ	250.0	279.00	309.00	1	405.0	0.99	5
SMAJ300A	SMAJ300CA	DE or TE	HE or UE	300.0	335.00	371.00	1	486.0	0.82	5
SMAJ350A	SMAJ350CA	DG or TG	HG or UG	350.0	391.00	432.00	1	567.0	0.71	5
SMAJ400A	SMAJ400CA	DK or TK	HK or UK	400.0	447.00	494.00	1	648.0	0.62	5
SMAJ440A	SMAJ440CA	DM or TM	HM or UM	440.0	492.00	543.00	1	713.0	0.56	5

Note:

1. Add suffix "CA" after Part number to specify Bi-directional devices.
2. For Bi-directional devices having  $V_{RWM}$  of 10 voltages and under, the  $I_R$  limit is doubled.



**Ordering Information:**

Device PN	Packing
Part Number -T <sup>(1)</sup> G <sup>(2)</sup> -WS	Tape & Reel Packing :5000pcs/Reel

- Note:**
1. Packing code, T: Tape & 13" Reel Packing;
  2. RoHS product for packing code suffix "G", Halogen free product for packing code suffix "H" .
  - 3 WS : Willas brand abbreviation, Label Type does not display

**\*\*\*Disclaimer\*\*\***

WILLAS reserves the right to make changes without notice to any product specification herein, to make corrections, modifications, enhancements or other changes. WILLAS or anyone on its behalf assumes no responsibility or liability for any errors or inaccuracies. Data sheet specifications and its information contained are intended to provide a product description only. "Typical" parameters which may be included on WILLAS data sheets and/ or specifications can and do vary in different applications and actual performance may vary over time. WILLAS does not assume any liability arising out of the application or use of any product or circuit.

WILLAS products are not designed, intended or authorized for use in medical, life-saving implant or other applications intended for life-sustaining or other related applications where a failure or malfunction of component or circuitry may directly or indirectly cause injury or threaten a life without expressed written approval of WILLAS. Customers using or selling WILLAS components for use in such applications do so at their own risk and shall agree to fully indemnify WILLAS Inc and its subsidiaries harmless against all claims, damages and expenditures.