



TAI-SAW TECHNOLOGY CO., LTD.

No. 3, Industrial 2nd Rd., Ping-Chen Industrial District,
Taoyuan, 324, Taiwan, R.O.C.

TEL: 886-3-4690038 FAX: 886-3-4697532

E-mail: tstsales@mail.taisaw.com Web: www.taisaw.com

Product Specifications Approval Sheet

Product Name: SAW Filter 1583 MHz SMD 3.0X3.0 mm (BW 48 MHz)

TST Parts No.:TE0142A

Customer Parts No.: _____

Customer signature required
Company: _____
Division: _____
Approved by : _____
Date: _____

Checked by: _____ Sam Lin *Sam Lin*

Approval by: _____ Andy Yu *Andy Yu*

Date: _____ 2019/03/06

1. Customer signed back is required before TST can proceed with sample build and receive orders.
2. Orders received without customer signed back will be regarded as agreement on the specifications.
3. Any specifications changes must be approved upon by both parties and a new revision of specifications shall be released to reflect the changes



TAI-SAW TECHNOLOGY CO., LTD.

No. 3, Industrial 2nd Rd., Ping-Chen Industrial District,
Taoyuan, 324, Taiwan, R.O.C.

TEL: 886-3-4690038 FAX: 886-3-4697532

E-mail: tstsales@mail.taisaw.com Web: www.taisaw.com

SAW Filter 1583 MHz SMD 3.0X3.0 mm (BW 48 MHz)

MODEL NO.:TE0142F

REV. NO.:1.0

A. MAXIMUM RATING:

1. Input Power Level: 10 dB_m
2. DC voltage: 3 V
3. Operating Temperature: : -30 °C to +70 °C
4. Storage Temperature: -40 °C to +85 °C
5. Moisture Sensitivity Level: Level 1 (MSL1)

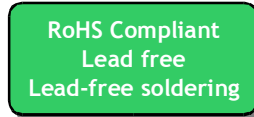

Electrostatic Sensitive Device

B. ELECTRICAL CHARACTERISTICS:

Item	Unit	Min.	Typ.	Max.
Center Frequency	MHz	-	1583	-
Maximum Insertion Loss				
689 ~ 960 MHz	dB	-	1.0	2.0
1710 ~ 1805 MHz	dB	-	1.2	2.5
1805 ~ 2170 MHz	dB	-	2.5	3.0
2300 ~ 2690 MHz	dB	-	3.5	4.0
Attenuation (Reference level from 0 dB)				
1559 ~ 1607 MHz	dB	14	15	-
Temperature Coefficient of Frequency	ppm/k	-	-75	-

C. MEASUREMENT CIRCUIT:

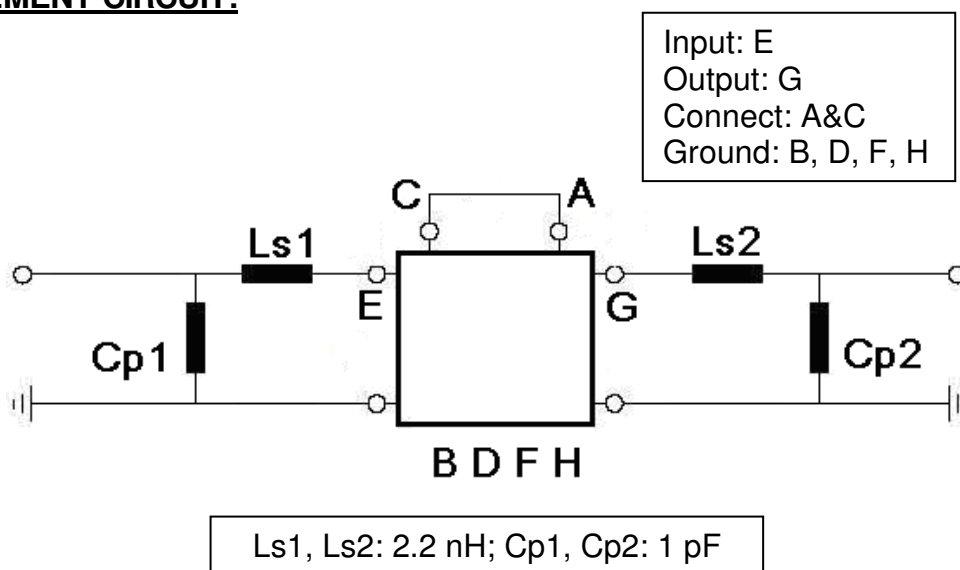

D.OUTLINE DRAWING:

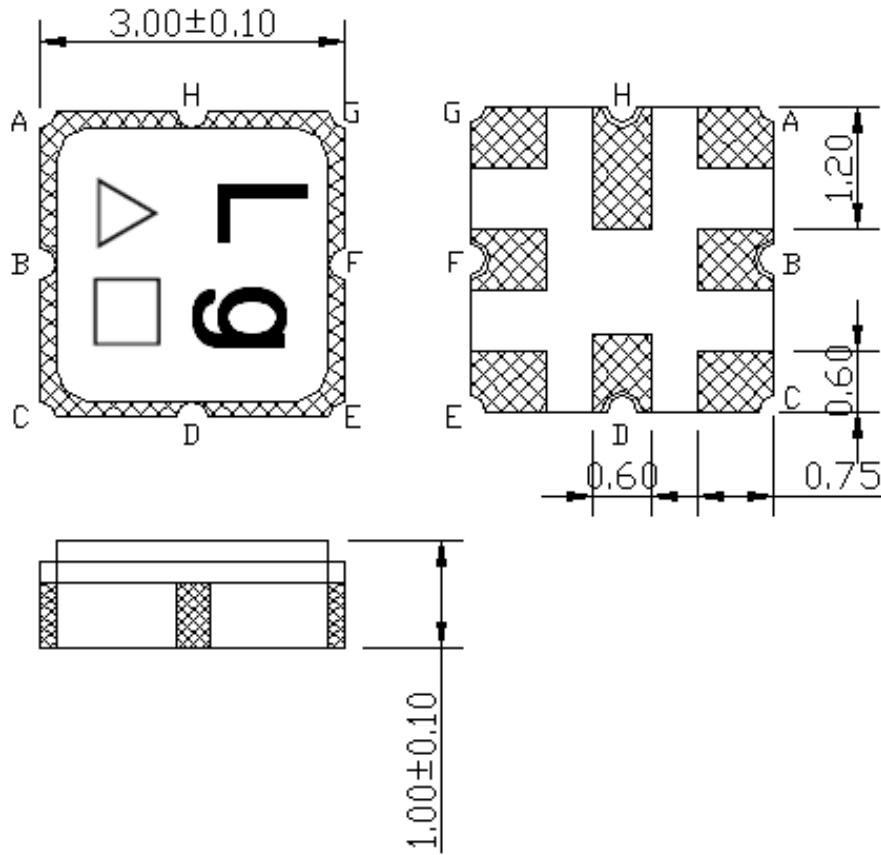

△ : Year Code (2009->9, 2010->0,..., 2018->8)

□ : Date Code (Follow the table from planner each year)

WK01	WK02	WK03	WK04	WK05	WK06	WK07	WK08	WK09	WK10	WK11	WK12	WK13
A	B	C	D	E	F	G	H	I	J	K	L	M
WK14	WK15	WK16	WK17	WK18	WK19	WK20	WK21	WK22	WK23	WK24	WK25	WK26
N	O	P	Q	R	S	T	U	V	W	X	Y	Z
WK27	WK28	WK29	WK30	WK31	WK32	WK33	WK34	WK35	WK36	WK37	WK38	WK39
a	b	c	d	e	f	g	h	i	j	k	l	m
WK40	WK41	WK42	WK43	WK44	WK45	WK46	WK47	WK48	WK49	WK50	WK51	WK52
n	o	p	q	r	s	t	u	v	w	x	y	z

E. Frequency Characteristics :
Span 400 MHz

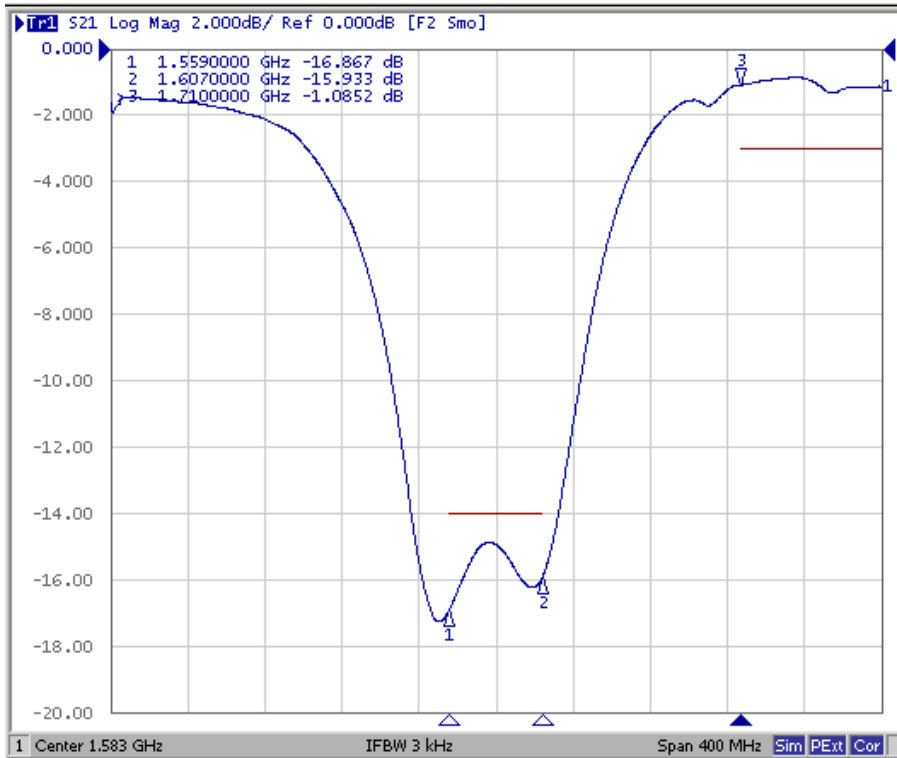

Span 3000 MHz

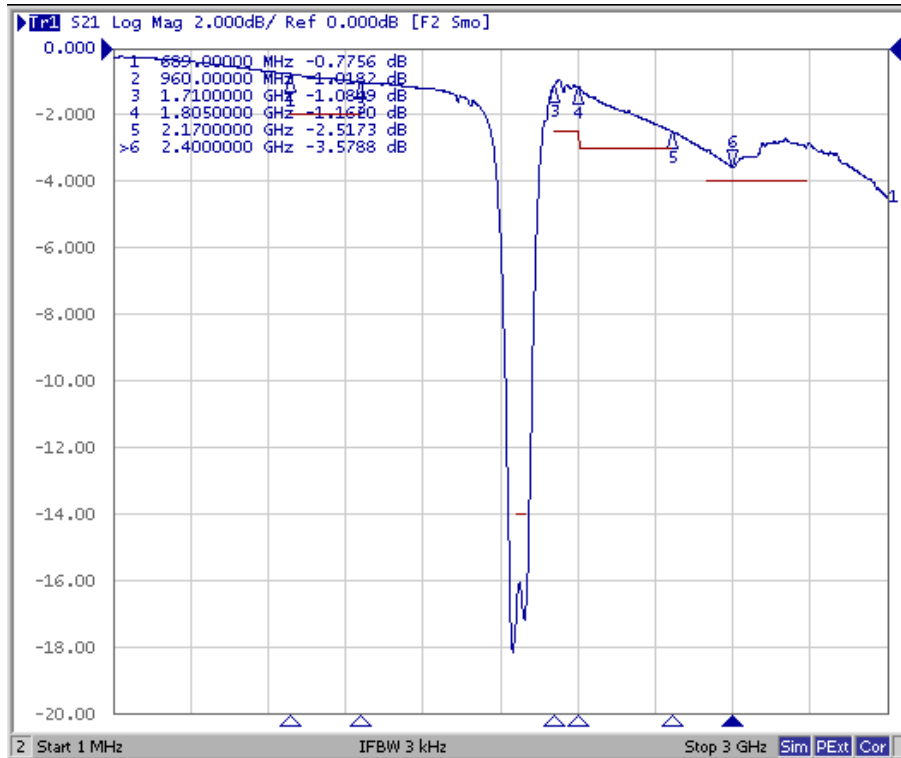

F. PCB FOOTPRINT:

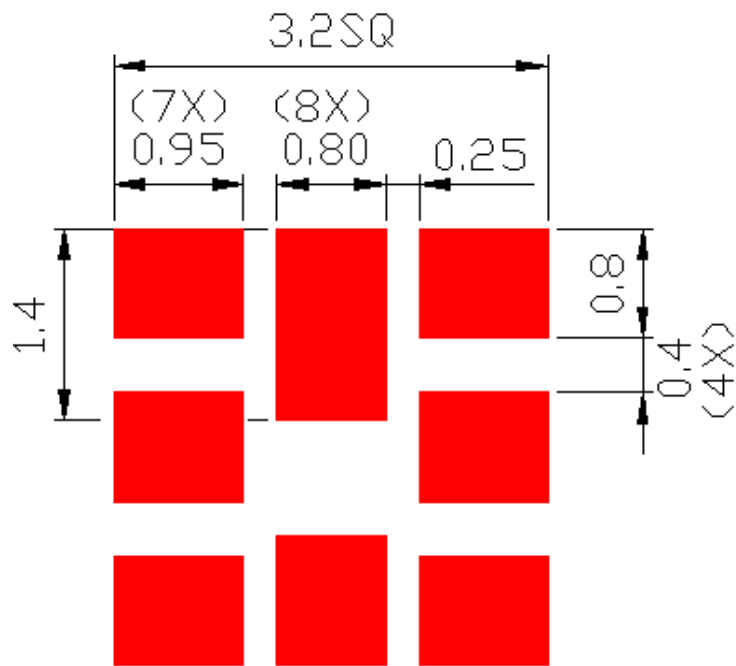

G. PACKING:

1. REEL DIMENSION

(Please refer to FR-75D10 for packing quantity)

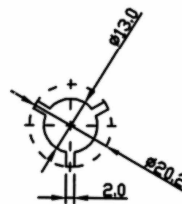
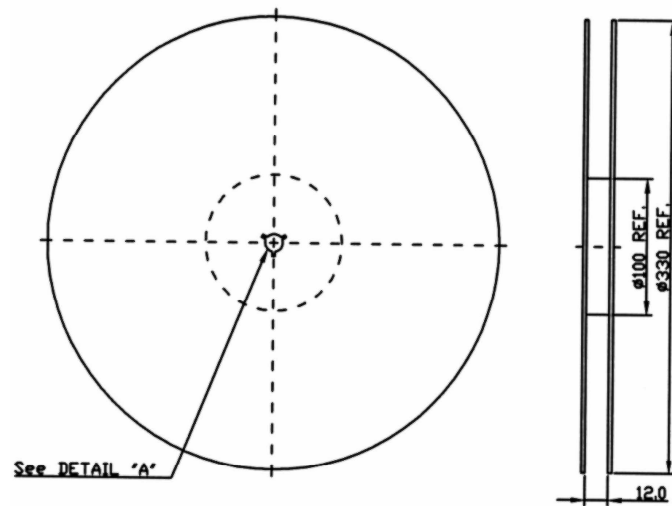

2. TAPE DIMENSION

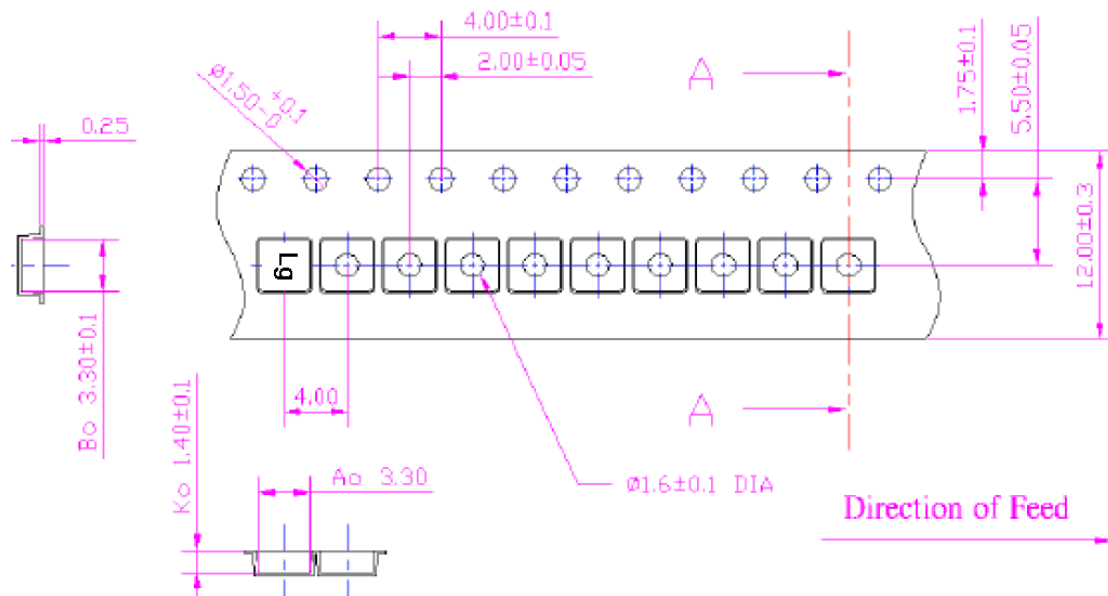

H. RECOMMENDED REFLOW PROFILE :

1. Preheating shall be fixed at $150 \sim 180^{\circ}\text{C}$ for $60 \sim 90$ seconds.
2. Ascending time to preheating temperature 150°C shall be 30 seconds min.
3. Heating shall be fixed at 220°C for $50 \sim 80$ seconds and at $260^{\circ}\text{C} + 0/-5^{\circ}\text{C}$ peak ($20 \sim 40$ sec).
4. Time: 2 times.

