

特性

- 100A/140A触点切换能力
- 适用于太阳能光伏发电用逆变器
- 触点间隙4mm
- 整机施加线圈保持电压, 节省电力损耗
- 外形尺寸: (45×41.4×43)mm

触点参数

触点形式	1A
接触电阻 ⁽¹⁾	≤6mΩ(20A 6VDC)
触点材料	银合金
触点负载(阻性)	接通30A, 载流100A, 断开30A 690VAC 85°C 接通40A, 载流140A, 断开40A 400VAC 85°C
最大切换额定电压	800VAC
最大切换额定电流	140A
最大切换额定功率	24000VA
机械耐久性	1,000,000次
电耐久性(阻性)	30,000 (接通30A,载流100A, 断开30A, 85°C, 1s通9s断) 30,000 (接通40A,载流140A, 断开40A, 85°C, 1s通9s断)

备注: (1) 上述值为初始值。

性能参数

绝缘电阻	1000MΩ(500VDC)	
介质耐压	线圈与触点间	5000VAC 1min
	断开触点间	2000VAC 1min
浪涌电压(线圈与触点间)	10kV(1.2/50us)	
动作时间(额定电压下)	≤30ms	
释放时间(额定电压下)	≤10ms	
线圈温升 (额定电压下)	≤70K(触点负载100A/140A,50%-60%, 额定电压激励,环境温度85°C)	
冲击	稳定性	98m/s ²
	强度	980m/s ²
振动	10Hz~55Hz 1.5mm 双振幅	
湿度	5%~85%Rh	
温度范围	-40°C~85°C(线圈施加保持电压)	
引出端形式	印制板式	
重量	约135g	

备注: 上述值为初始值。

线圈规格表

温度：23℃

额定电压 (VDC)	动作电压 (1) (VDC)	释放电压 (1) (VDC)	最大电压 (2) (VDC)	线圈电阻 ±10%(Ω)	线圈功率
6	≤4.5	≥0.3	6.6	14.4	2.5W
9	≤6.75	≥0.45	9.9	32.4	
12	≤9	≥0.6	13.2	57.6	
24	≤18	≥1.2	26.4	230.4	

备注：(1) 上述值为初始值；
 (2) 最大电压是指继电器线圈在短时间内能够承受的最大电压值。

安规认证

认证类别	_____
证书号	_____
负载要求	接通60A,载流100A, 断开60A, 277VAC,85℃ 接通30A,载流100A, 断开30A, 800VAC,85℃ 接通60A,载流140A, 断开60A, 277VAC,85℃ 接通40A,载流140A, 断开40A, 400VAC,85℃ 接通30A,载流140A, 断开30A, 800VAC,85℃

备注：表中未注明温度的负载，均指环境温度为室温。

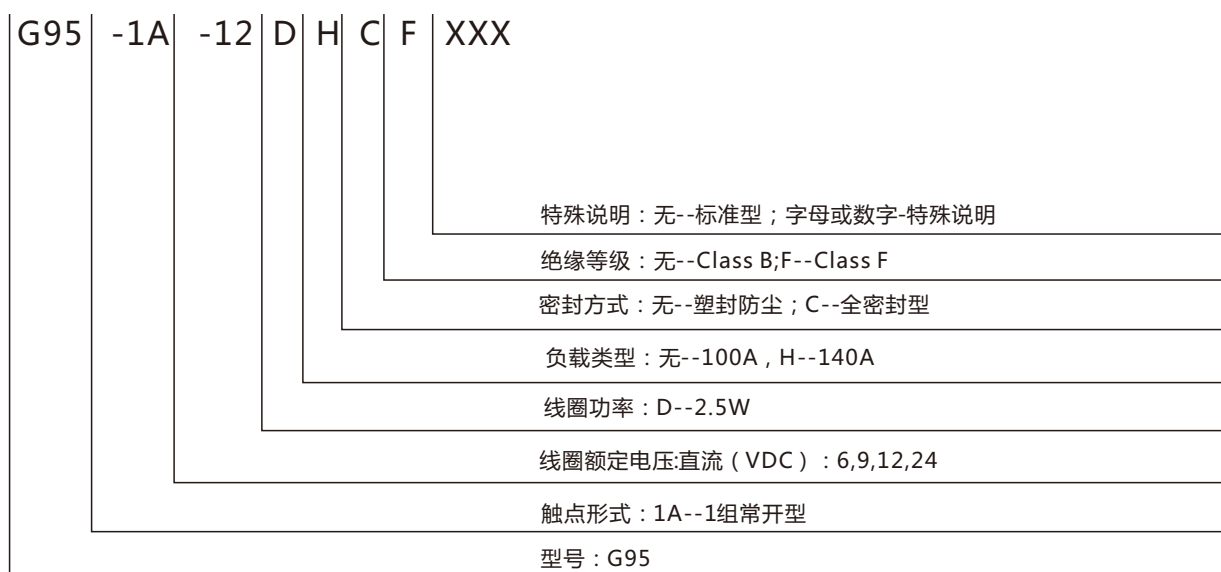
G95 命名规则

外形图

单位:mm

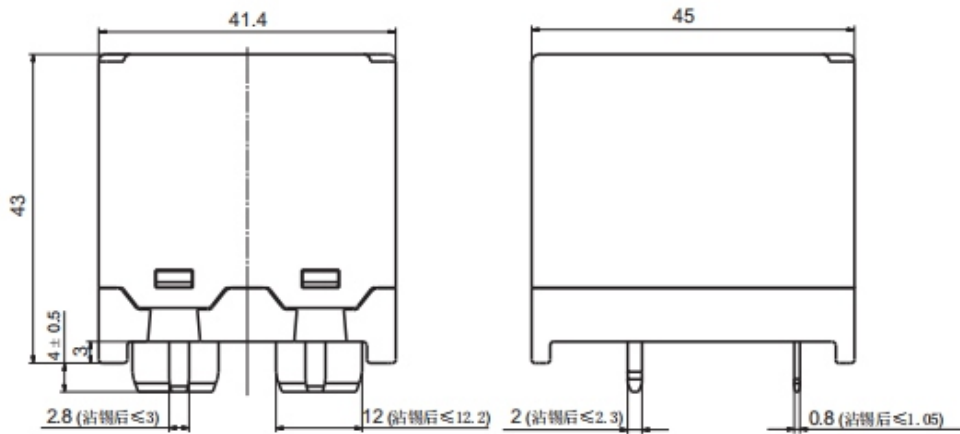

注：产品部分外形尺寸未注尺寸公差，当外形尺寸 < 1mm，公差为±0.2mm；
当外形尺寸在1~5mm之间时，公差为±0.3mm；当外形尺寸 > 5mm，公差为±0.4mm。

安装孔尺寸图(底视图)、接线图(底视图)

单位:mm

安装孔尺寸(底视图)

接线图
(底视图)

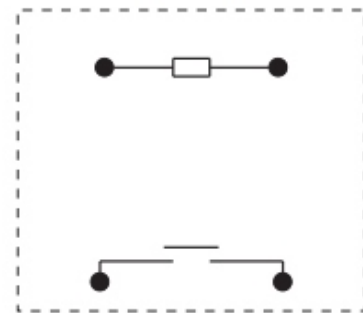
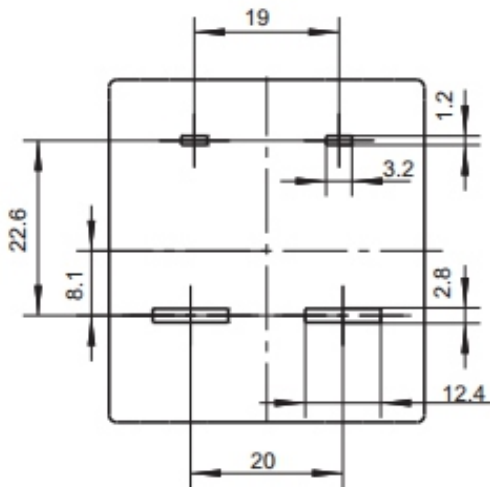

注：引出端子尺寸为预焊前尺寸；
安装孔尺寸公差：±0.1mm。

声明:

本产品规格书仅供客户使用时参考,若有更改,恕不另行通知。

对高登而言,不可能评定继电器在每个具体应用领域的所有性能参数要求,因而客户应该根据具体的使用条件选择与之相配的产品,若有疑问,请与高登联系获取更多的技术支持,但是产品选型责权由客户负责。

©深圳高登电科股份有限公司版权所有,本公司保留所有权利。

Characteristics

- 100A/140A contact switching capability
- Inverter for solar photovoltaic power generation
- Contact gap 4mm
- The whole machine applies coil holding voltage to save power loss
- Sizes:(45× 41.4×43)mm

Contact parameter

Contact form	1A
Contact resistance ⁽¹⁾	≤6mΩ(20A 6VDC)
Contact material	Silver alloy
Contact load (resistance)	Turn on 30A, carry 100A, disconnect 30A 690VAC 85°C Turn on 40A, carry 140A, disconnect 40A 400VAC 85°C
Max. Switching Voltage	800VAC
Max. Switching Current	140A
Max. Switching Power	24000VA
Mechanical Life	1,000,000 ops.
Electrical Life (Resistive)	30,000 (connect 30A, carry 100A, disconnect 30A, 85°C, 1s on 9s off) 30,000 (connect 40A, carry current 140A, disconnect 40A, 85°C, 1s on 9s off)

Note: (1) The above values are initial values.

Performance parameter

Insulation resistance	1000MΩ(500VDC)	
Dielectric Strength	Between coil & contacts	5000VAC 1min
	Between open contacts	2000VAC 1min
Surge voltage (between coil and contacts)	10kV(1.2/50us)	
Operating time (at rated voltage)	≤30ms	
Release time (at rated voltage)	≤10ms	
Coil temperature rise (at rated voltage)	≤70K (contact load 100A/140A, 50%-60%, Rated voltage excitation, ambient temperature 85°C)	
Impact resistance	Malfunction	98m/s ²
	Durability	980m/s ²
Vibration resistant	10Hz ~ 55Hz 1.5mm double amplitude	
Humidity	5% ~ 85%Rh	
Operating Condition	-40°C ~ 85°C (hold voltage applied to coil)	
Terminal Type	PCB	
weight	About 135g	

Note: The above values are initial values.

Coil parameter					Temperature: 23°C
Nominal Voltage (VDC)	Operating voltage ⁽¹⁾ (VDC)	Release voltage ⁽¹⁾ (VDC)	Maximum voltage ⁽²⁾ (VDC)	Coil resistance ±10%(Ω)	Coil rated power (W)
6	≤4.5	≥0.3	6.6	14.4	2.5W
9	≤6.75	≥0.45	9.9	32.4	
12	≤9	≥0.6	13.2	57.6	
24	≤18	≥1.2	26.4	230.4	

Note: (1) The above values are initial values;
 (2) The maximum voltage refers to the maximum voltage that the relay coil can withstand in a short time.

Safety certification	
Certification category	_____
Certificate No	_____
Load requirement	Turn on 60A, carry 100A, turn off 60A, 277VAC, 85°C Turn on 60A, carry 140A, turn off 60A, 277VAC, 85°C Turn on 30A, carry 100A, turn off 30A, 800VAC, 85°C Turn on 40A, carry 140A, turn off 40A, 400VAC, 85°C Turn on 30A, carry 140A, turn off 30A, 800VAC, 85°C

G95 Naming rules

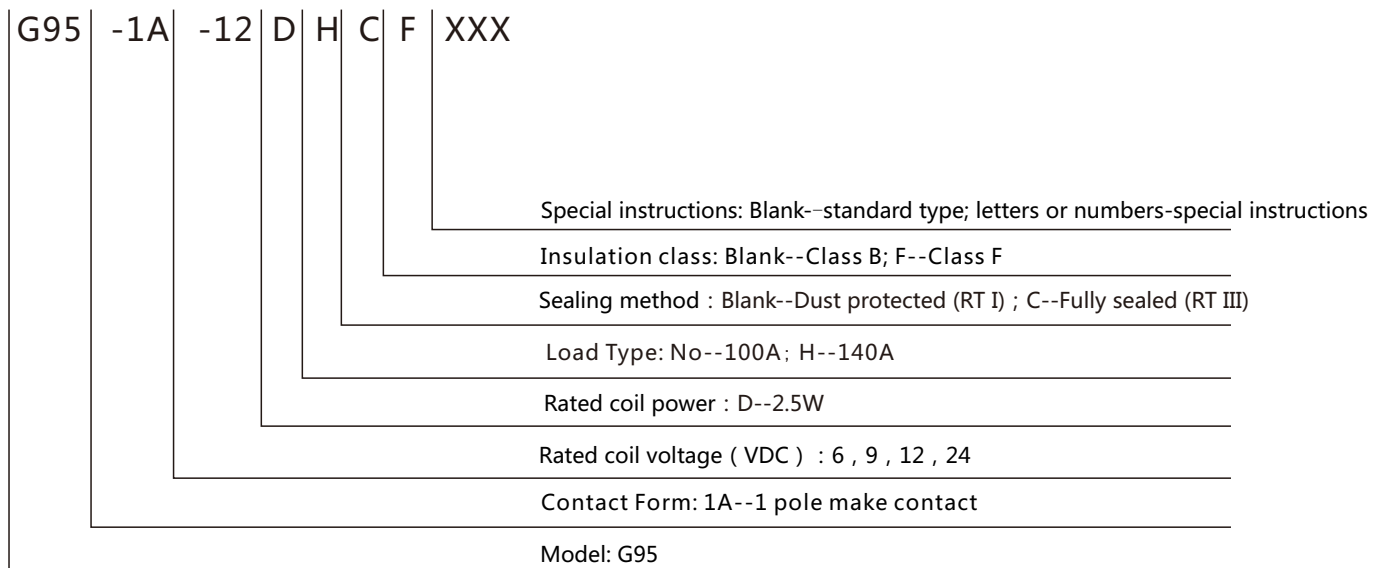

Outline drawing

Unit: mm

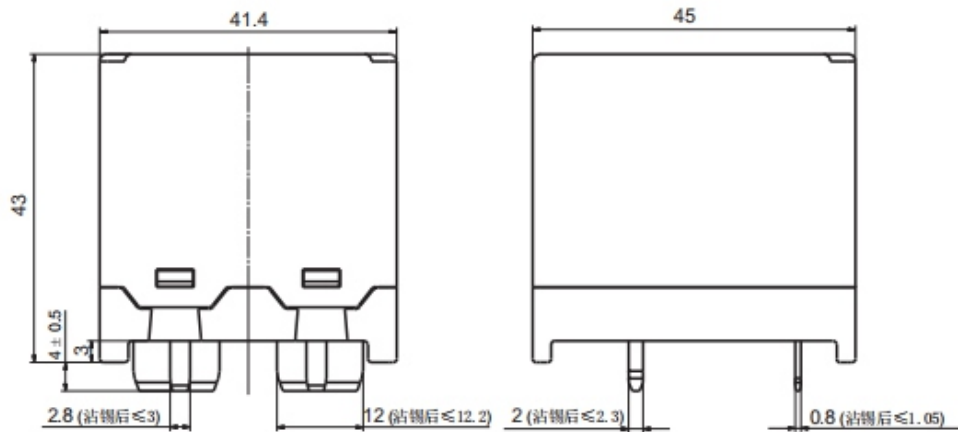

Note: Part of the product has no tolerances on the external dimensions.
 When the external dimensions are less than 1mm, the tolerance is $\pm 0.2\text{mm}$;
 When the external dimension is between 1~5mm, the tolerance is $\pm 0.3\text{mm}$;
 When the external dimension $> 5\text{mm}$, the tolerance is $\pm 0.4\text{mm}$.

PCB Layout (bottom view)、Wiring diagram (bottom view)

Unit: mm

PCB Layout (bottom view)

安装孔尺寸(底视图)

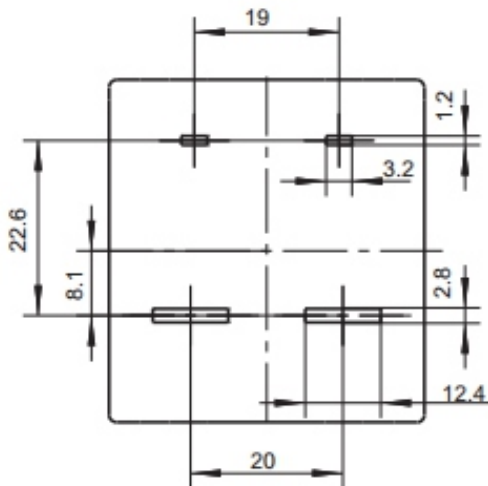

Wiring diagram (bottom view)

接线图
(底视图)

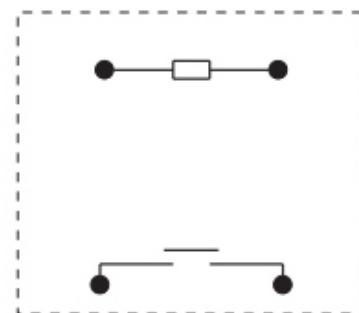

Note: The size of the lead terminal is the size before pre-welding;
 the size tolerance of the mounting hole: $\pm 0.1\text{mm}$.

statement:

This product specification is only for reference when customers use it, and subject to change without notice.

For Golden, it is impossible to evaluate all the performance parameter requirements of the relay in each specific application field. Therefore, the customer should choose the product that matches it according to the specific use conditions. If you have questions, please contact Golden for more technical support, but the customer is responsible for product selection.

©Shenzhen Golden Electronics Co., Ltd. All rights reserved. All rights are reserved by the company.