

DESCRIPTION

The LX1431 is an adjustable shunt voltage regulator featuring 100mA sink capability, a 0.4% initial reference voltage tolerance and a 0.3% typical temperature stability. This product, which is ideal for use in Pentium® applications, is equipped with on-chip divider resistors, enabling it to be configured as a 5V shunt regulator. In this configuration, the LX1431 has an initial voltage tolerance of *only* 1% and requires no additional external components.

The Linfinité LX1431EB evaluation board and design kit is available to assist engineers in quickly configuring the most efficient, cost-effective Pentium designs.

The output voltage of the LX1431 may be set to any value between 2.5V and 36V through the addition of two external resistors, which is of particular importance in the design of both adjustable and switching power supplies.

In addition, the nominal internal current limit of 100mA may be decreased with the addition of a single external resistor.

For applications requiring an adjustable reference, the Linfinité LX6431CLP, a simplified three-pin programmable reference, may be used. Because the LX6431 is pin-for-pin compatible with Linfinité's earlier TL431, use of this product provides designers a simple migration path to the more robust LX6431. A separate LX6431 data sheet is available which details the specifics of this product.

In addition, Pentium designers may use Linfinité's LX8585/8585A 4.6A or LX8584/8584A 7A Low Dropout Regulators to achieve the most optimum motherboard configuration.

KEY FEATURES

- Guaranteed 0.4% Initial Voltage Tolerance
- 0.1Ω Typical Dynamic Output Impedance
- Fast Turn-on
- Sink Current Capability, 1mA to 100mA
- Low Reference Pin Current

APPLICATIONS

- Linear Regulators
- Adjustable Power Supplies
- Switching Power Supplies
- LX1432EB Evaluation Board For Pentium Applications Available

**IMPORTANT:** For the most current data, consult MICROSEMI's website: <http://www.microsemi.com>

PRODUCT HIGHLIGHT

THE LX8584A & LX431 IN 75 & 166MHz P54C PROCESSOR APPLICATIONS USING 3.3V CACHE

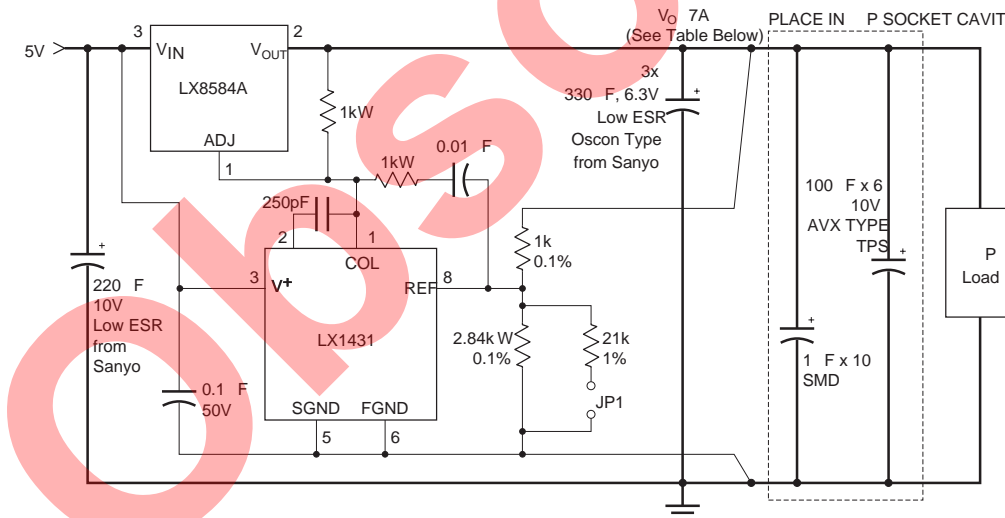

V <sub>O</sub>	JP1	TYPICAL APPLICATION
3.50	Short	120/166MHz, VRE, 3.3V Cache
3.38	Open	75/90/100/133MHz, STND, 3.3V Cache

Thick traces represent high current traces which must be low resistance / low inductance traces in order to achieve good transient response.

PACKAGE ORDER INFO

T <sub>A</sub> (°C)	M Plastic DIP 8-Pin	DM Plastic SOIC 8-Pin
		RoHS Compliant / Pb-free Transition DC: 0503
0 to 70	LX1431CM	LX1431CDM
-40 to 85	LX1431IM	LX1431IDM

Note: Available in Tape & Reel. Append the letters "TR" to the part number (i.e. LX1431CDM-TR).

## PROGRAMMABLE REFERENCE PRODUCTION DATA SHEET

### ABSOLUTE MAXIMUM RATINGS (Note 1)

$V^+$ , $V_{\text{COLLECTOR}}$ .....	36V
$V_{\text{COMP}}$ , $R_{\text{TOP}}$ , $R_{\text{MID}}$ , $V_{\text{REF}}$ .....	6V
GND-F to GND-S .....	0.7V
Operating Junction Temperature	
Plastic (M, DM Packages) .....	150°C
Storage Temperature Range .....	-65°C to 150°C
Lead Temperature .....	300°C
Pb-free / RoHS Peak Package Solder Reflow Temp. (40 second max. exposure).....	260°C (+0, -5)

Note 1. Exceeding these ratings could cause damage to the device. All voltages are with respect to Ground. Currents are positive into, negative out of the specified terminal.

### THERMAL DATA

#### M PACKAGE:

THERMAL RESISTANCE-JUNCTION TO AMBIENT, $\theta_{JA}$	95°C/W
---	--------

#### DM PACKAGE:

THERMAL RESISTANCE-JUNCTION TO AMBIENT, $\theta_{JA}$	165°C/W
---	---------

Junction Temperature Calculation:  $T_J = T_A + (P_D \times \theta_{JA})$ .

The  $\theta_{JA}$  numbers are guidelines for the thermal performance of the device/pc-board system. All of the above assume no ambient airflow.

### PACKAGE PIN OUTS

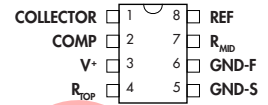

M PACKAGE  
(Top View)



DM PACKAGE  
(Top View)

RoHS / Pb-free 100% Matte Tin Lead Finish

### BLOCK DIAGRAM

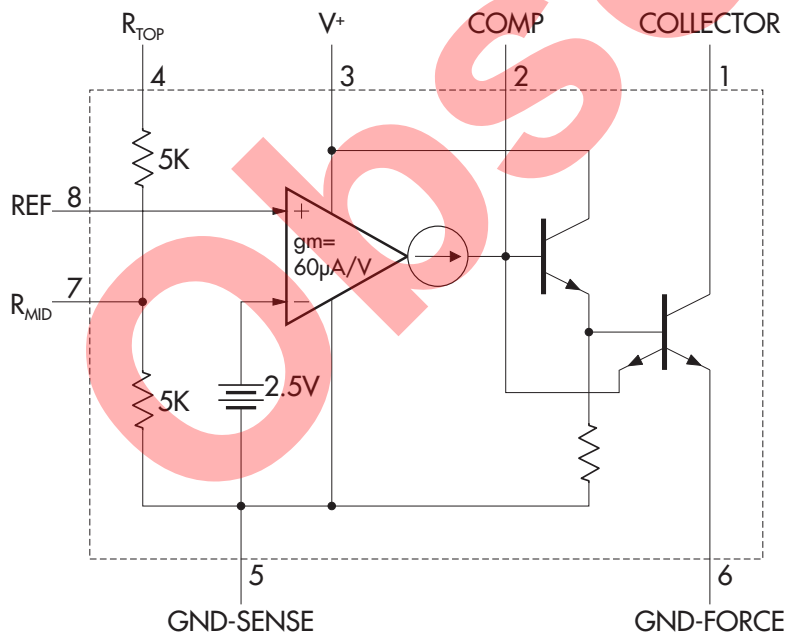

## PROGRAMMABLE REFERENCE

## PRODUCTION DATA SHEET

## ELECTRICAL CHARACTERISTICS

(Unless otherwise specified, these specifications apply over the operating ambient temperatures for LX1431C with  $0^{\circ}\text{C} \leq T_A \leq 70^{\circ}\text{C}$ , LX1431I with  $-40^{\circ}\text{C} \leq T_A \leq 85^{\circ}\text{C}$ .)

Parameter	Symbol	Test Conditions	LX1431I			LX1431C			Units
			Min.	Typ.	Max.	Min.	Typ.	Max.	
Reference Voltage	$V_{REF}$	$V_{KA} = 5V, I_K = 2mA, T_A = 25^{\circ}\text{C}$	2490	2500	2510	2490	2500	2510	mV
		$V_{KA} = 5V, I_K = 2mA$	2465		2535	2480		2520	mV
Reference Drift	$\Delta V_{REF}/\Delta T$	$V_{KA} = 5V, I_K = 2mA$		50			30		ppm/ $^{\circ}\text{C}$
Voltage Ratio, Reference to Cathode (Open Loop Gain)	$\frac{\Delta V_{REF}}{\Delta V_{KA}}$	$I_K = 2mA, V_{KA} = 3V \text{ to } 36V$		0.2	1.0		0.2	1.0	mV/V
Reference Input Current	$[I_{REF}]$	$V_{KA} = 5V, T_A = 25^{\circ}\text{C}$		0.2	1		0.2	1	$\mu\text{A}$
		$V_{KA} = 5V$			1.5			1.2	$\mu\text{A}$
Minimum Operating Current	$I_{MIN}$	$V_{KA} = V_{REF} \text{ to } 36V, T_A = 25^{\circ}\text{C}$		0.6	1		0.6	1	mA
Off-State Cathode Current	$[I_{OFF}]$	$V_{KA} = 36V, V_{REF} = 0V, T_A = 25^{\circ}\text{C}$			1			1	$\mu\text{A}$
		$V_{KA} = 36V, V_{REF} = 0V$			15			2	$\mu\text{A}$
Off-State Collector Leakage Current	$[I_{LEAK}]$	$V_{COLL} = 36V, V^+ = 5V, V_{REF} = 2.4V, T_A = 25^{\circ}\text{C}$			1			1	$\mu\text{A}$
		$V_{COLL} = 36V, V^+ = 5V, V_{REF} = 2.4V$			5			2	$\mu\text{A}$
Dynamic Impedance	$[Z_{KA}]$	$V_{KA} = V_{REF}, I_K = 1mA \text{ to } 100mA, f \leq 1kHz, T_A = 25^{\circ}\text{C}$			0.1			0.1	$\Omega$
Collector Current Limit	$I_{LIM}$	$V_{KA} = V_{REF} + 50mV$	80		360	100		360	mA
5V Reference Output		Internal Divider Used, $I_K = 2mA, T_A = +25^{\circ}\text{C}$	4950	5000	5050	4950	5000	5050	mV

## APPLICATION INFORMATION

## PIN FUNCTIONS

**Pin 1 COLL:** Open collector of the output transistor. The maximum pin voltage is 36V. The saturation voltage at 100mA is approximately 1V.

**Pin 2 COMP:** Base of the driver for the output transistor. This pin allows additional compensation for complex feedback systems and shutdown of the regulator. It must be left open if unused.

**Pin 3 V<sup>+</sup>:** Bias voltage for the entire shunt regulator. The maximum input voltage is 36V and the minimum to operate is equal to  $V_{REF}$  (2.5V). The quiescent current is typically 0.6mA.

**Pin 4 R<sub>TOP</sub>:** Top of the on-chip 5k-5k resistive divider that guarantees 1% accuracy of operation as a 5V shunt regulator with no external trim. The pin is tied to COLL for self-contained 5V operation. It may be left open if unused.

**Pin 5 GND-S:** Ground reference for the on-chip resistive divider and shunt regulator circuitry except for the output transistor. This pin allows external current limit of the output transistor with one resistor between GND-F (force) and GND-S (sense).

**Pin 6 GND-F:** Emitter of the output transistor and substrate connection for the die.

**Pin 7 R<sub>MID</sub>:** Middle of the on-chip resistive divider string between R<sub>TOP</sub> and GND-S. The pin is tied to REF for self-contained 5V operation. It may be left open if unused.

**Pin 8 REF:** Control pin of the shunt regulator with a 2.5V threshold.

COMP, R<sub>TOP</sub>, R<sub>MID</sub>, and REF have static discharge protection circuits that must not be activated on a continuous basis. Therefore, the absolute maximum DC voltage on these pins is 6V, well beyond the normal operating conditions.

As with all bipolar ICs, the LX1431 contains parasitic diodes which must not be forward biased or else anomalous behavior will result. Pin conditions to be avoided are R<sub>TOP</sub> below R<sub>MID</sub> in voltage and any pin below GND-F in voltage (except for GND-S).

## FREQUENCY COMPENSATION

Excess capacitance on the REF pin can introduce enough phase shift to induce oscillation when configured as a reference >2.5V. This can be compensated with capacitance between COLL and REF (phase lead). More complicated feedback loops may require shaping of the frequency response of the LX1431 with dominant pole or pole-zero compensation. This can be accomplished with a capacitor or series resistor and capacitor between COLL and COMP.

The compensation schemes mentioned above use voltage feedback to stabilize the circuits. There must be voltage gain at the COLL pin for them to be effective, so the COLL pin must see a reasonable AC impedance. Capacitive loading of the COLL pin reduces the AC impedance, voltage gain, and frequency response, thereby decreasing the effectiveness of the compensation schemes, but also decreasing their necessity.

PROGRAMMABLE REFERENCE  
PRODUCTION DATA SHEET

GRAPH / CURVE INDEX

Characteristic Curves

FIGURE #

1. COLLECTOR  $V_{SAT}$  vs. TEMPERATURE vs. CURRENT
2. COMPENSATION PIN VOLTAGE vs. TEMPERATURE vs.  $I_{COLL}$
3.  $I_{LIMIT}$  vs. TEMPERATURE WITH EXTERNAL RESISTOR
4. REFERENCE VOLTAGE and REFERENCE CURRENT vs.  $V+$
5. REFERENCE VOLTAGE and REFERENCE CURRENT vs.  $V+$
6. 2.5V REFERENCE  $I_K$  vs.  $V_{KA}$
7. REFERENCE VOLTAGE and REFERENCE CURRENT vs. TEMPERATURE

Obsolete

### CHARACTERISTIC CURVES

**FIGURE 1.** — COLLECTOR  $V_{SAT}$  vs. TEMPERATURE vs. CURRENT

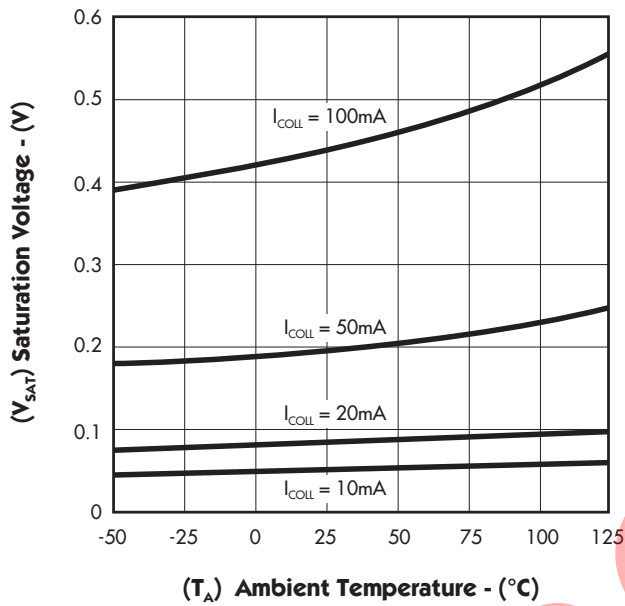

**FIGURE 2.** — COMPENSATION PIN VOLTAGE vs. TEMPERATURE vs.  $I_{COLL}$

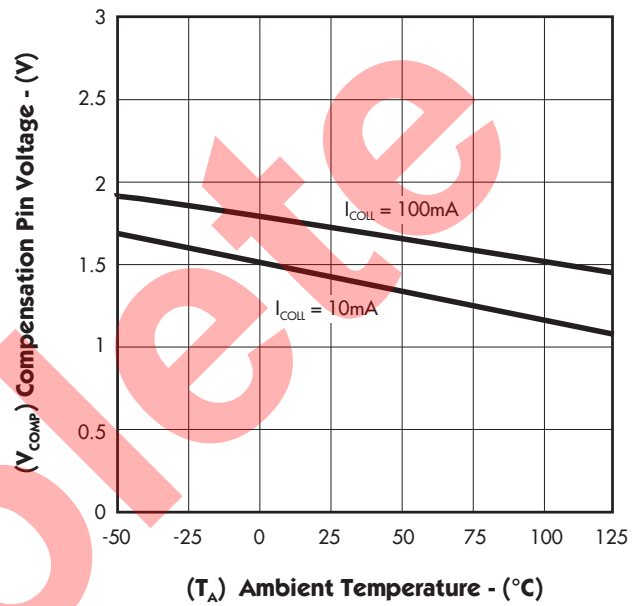

**FIGURE 3.** —  $I_{LIMIT}$  vs. TEMPERATURE WITH EXTERNAL RESISTOR

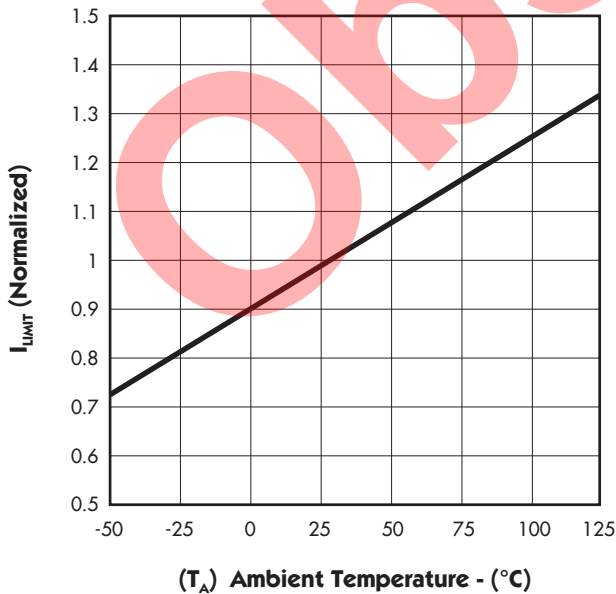

**FIGURE 4.** — REFERENCE VOLTAGE and REFERENCE CURRENT vs.  $V_+$

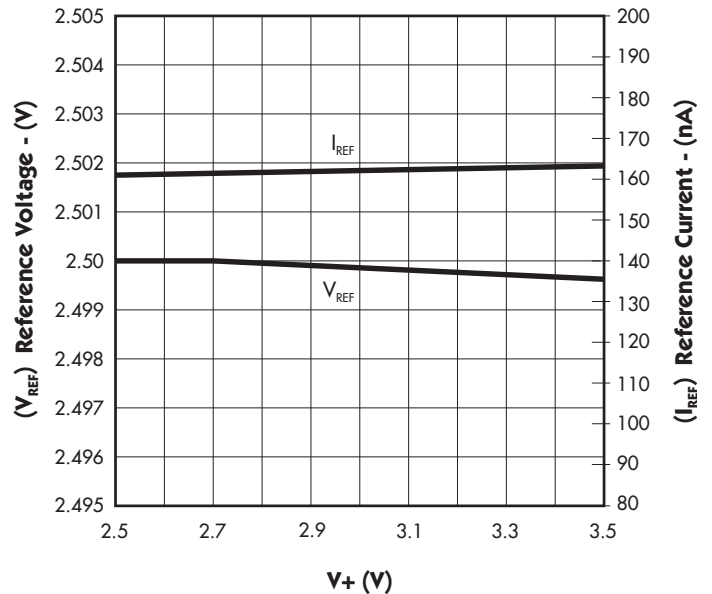

PROGRAMMABLE REFERENCE  
 PRODUCTION DATA SHEET

CHARACTERISTIC CURVES

FIGURE 5. — REFERENCE VOLTAGE and REFERENCE CURRENT vs.  $V_+$

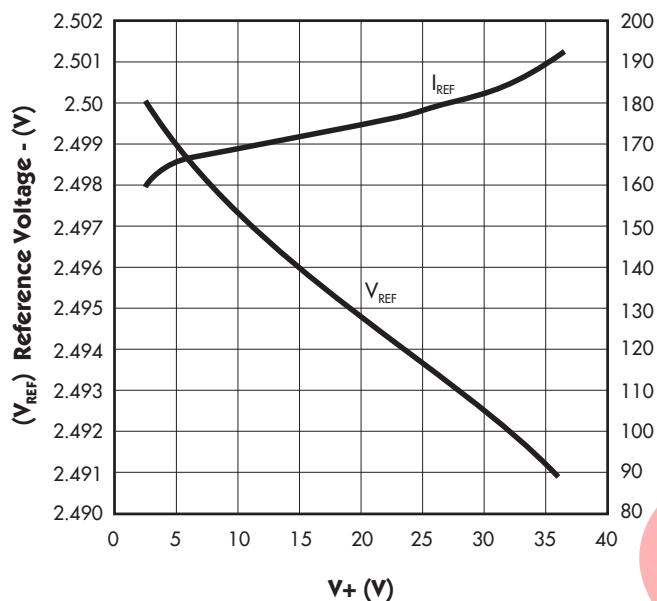

FIGURE 6. — 2.5V REFERENCE  $I_k$  vs.  $V_{KA}$

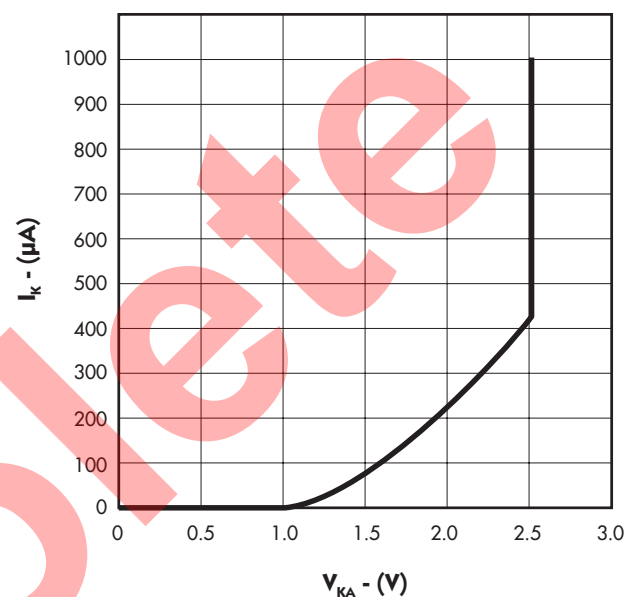

FIGURE 6. — REFERENCE VOLTAGE and REFERENCE CURRENT vs. TEMPERATURE

