

SUPER-LOW CURRENT CONSUMPTION 150 mA VOLTAGE REGULATOR WITH BUILT-IN HIGH-ACCURACY VOLTAGE DETECTOR AND RESET INPUT FUNCTION

www.sii-ic.com

© Seiko Instruments Inc., 2008-2012

Rev.2.1_00

The S-1702 Series, developed based on CMOS technology, is a 150 mA output positive voltage regulator with a low dropout voltage, a high-accuracy output voltage, and low current consumption.

The S-1702 Series includes a voltage regulator with high-accuracy output voltage of $\pm 1.0\%$ allowing to use a ceramic capacitor of 1.0 μF or more, and a voltage detector that monitors the output/input voltage of the regulator. It also includes an overcurrent protector that prevents the output current from exceeding the current capacitance of the output transistor and an output forcible discharge circuit for the regulator operation off.

Small SNT-6A package is available for the S-1702 Series. And an external small capacitor can be used, enabling high-density mounting. Its super-low current consumption makes the S-1702 Series ideal for mobile devices.

■ Features

Regulator block

- Output voltage: 1.5 V to 5.5 V, selectable in 0.05 V step
- High-accuracy output voltage: $\pm 1.0\%$
- Super-low current consumption: Current consumption of regulator block: 9 μA typ., 16 μA max.
- High peak current capability: 150 mA output ($V_{\text{IN}} \geq V_{\text{OUT(S)}} + 1.0 \text{ V}$)^{*1}
- Built-in on/off discharge circuit: Longer battery life, discharges output load instantaneously
- High ripple rejection: 70 dB typ. (1.0 kHz)
- Built-in overcurrent protector: Limits overcurrent of output transistor

Detector block

- Output voltage: 1.3 V to 5.2 V, selectable in 0.05 V step
- Built-in high-accuracy voltage detector: $\pm 1.0\%$
Monitoring output/input or monitoring external input by option (detector output)
- External reset input: Forcible assertion of detector output by external reset pin (RESX) input

Overall

- Correlation temperature gradient in the regulator and the detector blocks
- Super-low current consumption: During operation^{*2}: 10 μA typ., 18 μA max.
- Operation temperature range: $T_a = -40^\circ\text{C}$ to $+85^\circ\text{C}$
- Lead-free, Sn 100%, halogen-free^{*3}

*1. Attention should be paid to the power dissipation of the package when the output current is large.

*2. Excluding current flowing in pull-up and pull-down resistors connected to the ON / OFF or RESX pins

*3. Refer to "■ Product Name Structure" for details.

■ Applications

- Wireless power supply circuit block for cellular phone
- Power supply circuit block for health care product
- Power supply circuit block for various mobile devices

■ Package

- SNT-6A

■ **Block Diagrams**

1. **S-1702 Series A type to H type**

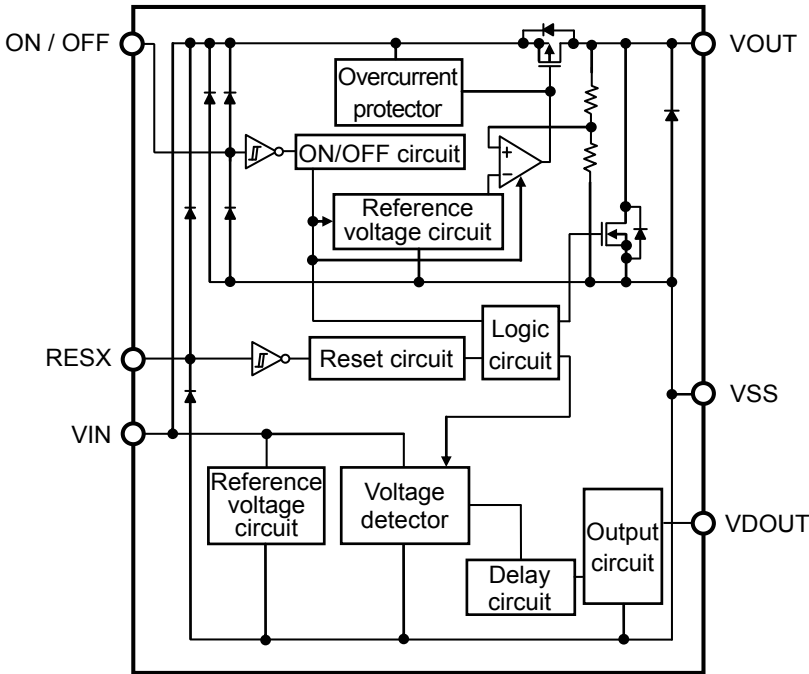

Figure 1

Product Type	Detector Monitor Voltage	Discharge Shunt Function by ON / OFF and RESX Pins	
		Control by ON / OFF Pin	Control by RESX Pin
A	V _{OUT}	○	○
B	V _{OUT}	○	×
C	V _{OUT}	×	○
D	V _{OUT}	×	×
E	V _{IN}	○	○
F	V _{IN}	○	×
G	V _{IN}	×	○
H	V _{IN}	×	×

2. **S-1702 Series J type and K type (external input detection type)**

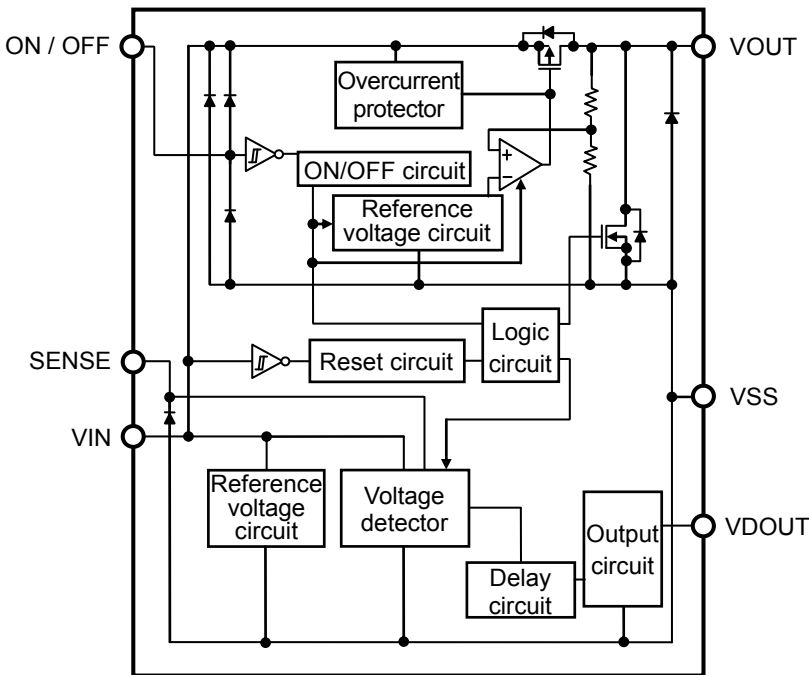
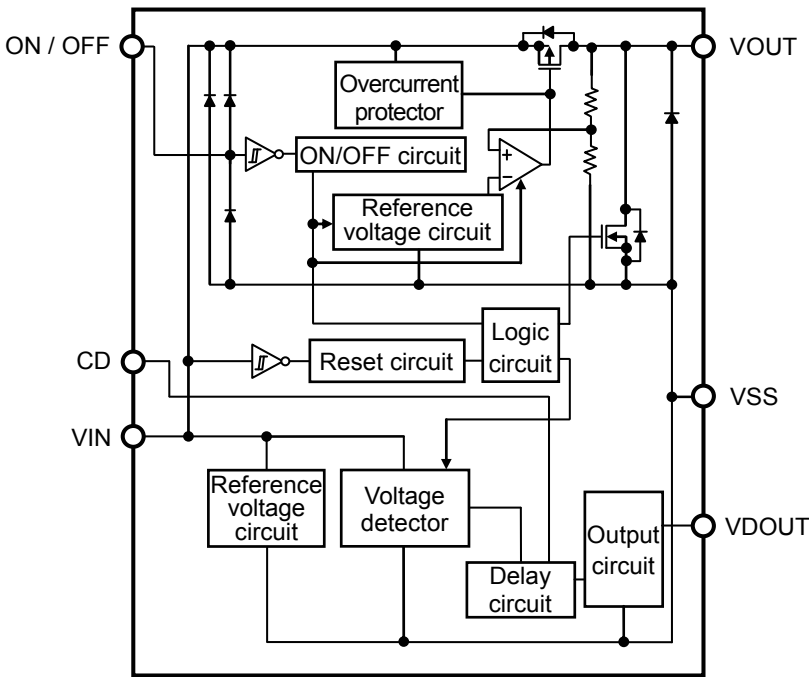

Figure 2

Product Type	Detector Monitor Voltage	Discharge Shunt Function by ON / OFF Pin
J	External input	○
K	External input	×

3. S-1702 Series L type to N type, P type (external delay type)



Product Type	Detector Monitor Voltage	Discharge Shunt Function by ON / OFF Pin
L	V_{OUT}	○
M	V_{OUT}	×
N	V_{IN}	○
P	V_{IN}	×

Figure 3

■ Product Name Structure

1. Product name

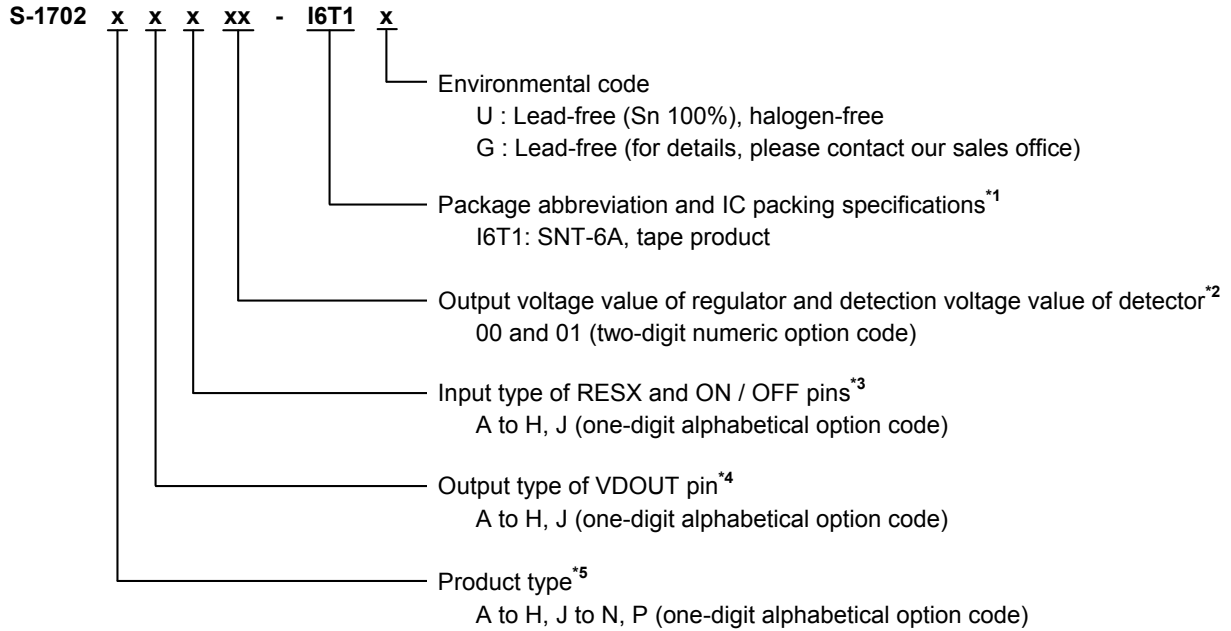

*1. Refer to the tape drawing.

*2. Refer to **Table 4** of “**2. Function list according to product type**”.

*3. Refer to **Table 3** of “**2. Function list according to product type**”.

*4. Refer to **Table 2** of “**2. Function list according to product type**”.

*5. Refer to **Table 1** of “**2. Function list according to product type**”.

2. Function list according to product type

Table 1 Product Types

Option Code	ON / OFF Pin Application	RESX Pin Application	Delay Type	Detector Monitor Voltage	Discharge Shunt Function	
					Control by ON / OFF Pin	Control by RESX Pin
A	ON / OFF	RESX	Internal	V_{OUT}	○	○
B	ON / OFF	RESX	Internal	V_{OUT}	○	×
C	ON / OFF	RESX	Internal	V_{OUT}	×	○
D	ON / OFF	RESX	Internal	V_{OUT}	×	×
E	ON / OFF	RESX	Internal	V_{IN}	○	○
F	ON / OFF	RESX	Internal	V_{IN}	○	×
G	ON / OFF	RESX	Internal	V_{IN}	×	○
H	ON / OFF	RESX	Internal	V_{IN}	×	×
J	ON / OFF	SENSE	Internal	V_{SENSE}	○	—
K	ON / OFF	SENSE	Internal	V_{SENSE}	×	—
L	ON / OFF	CD	External	V_{OUT}	○	—
M	ON / OFF	CD	External	V_{OUT}	×	—
N	ON / OFF	CD	External	V_{IN}	○	—
P	ON / OFF	CD	External	V_{IN}	×	—

Table 2 Output Types of VDOUT Pin

Option Code	Output Type	Hysteresis
A	Nch open drain output	5.0%
B	CMOS output (V_{OUT} drive)	5.0%
C	CMOS output (V_{IN} drive)	5.0%
D	Nch open drain output	2.5%
E	CMOS output (V_{OUT} drive)	2.5%
F	CMOS output (V_{IN} drive)	2.5%
G	Nch open drain output	None
H	CMOS output (V_{OUT} drive)	None
J	CMOS output (V_{IN} drive)	None

Table 3 Input Types of RESX and ON / OFF Pins

Option Code	RESX Pin	ON / OFF Pin
A	No pull-up/pull-down resistor	No pull-up/pull-down resistor
B	No pull-up/pull-down resistor	Pull-up
C	No pull-up/pull-down resistor	Pull-down
D	Pull-up	No pull-up/pull-down resistor
E	Pull-up	Pull-up
F	Pull-up	Pull-down
G	Pull-down	No pull-up/pull-down resistor
H	Pull-down	Pull-up
J	Pull-down	Pull-down

Table 4 Output Voltage Values of Regulator and Detection Voltage Values of Detector

Option Code	Output Voltage	Detection Voltage
00	3.1 V \pm 1.0%	2.75 V \pm 1.0%
01	3.1 V \pm 1.0%	2.60 V \pm 1.0%

Remark Please contact our sales office for products with an output voltage or detection voltage other than those specified above.

3. Package

Package Name	Drawing Code			
	Package	Tape	Reel	Land
SNT-6A	PG006-A-P-SD	PG006-A-C-SD	PG006-A-R-SD	PG006-A-L-SD

■ Pin Configuration

1. SNT-6A

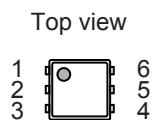

Figure 4

Table 5

Pin No.	Symbol	Description
1	VIN	Input voltage pin
2	ON / OFF	Power-off pin
3	RESX	External reset pin (S-1702Axx to Hxx)
	CD	External delay capacitor connection pin (S-1702Lxx to Nxx, Pxx)
	SENSE	Detector SENSE pin (S-1702Jxx, Kxx)
4	VSS	GND pin
5	VDOUT	Detector output voltage pin
6	VOUT	Regulator output voltage pin

■ **Absolute Maximum Ratings**

Table 6

(Ta = +25°C unless otherwise specified)

Item	Symbol	Absolute Maximum Rating	Unit
Input voltage	V _{IN}	V _{SS} - 0.3 to V _{SS} + 7.0	V
	V _{ON / OFF}	V _{SS} - 0.3 to V _{IN} + 0.3	V
	V _{RESX}	V _{SS} - 0.3 to V _{IN} + 0.3	V
	V _{CD}	V _{SS} - 0.3 to V _{IN} + 0.3	V
	V _{SENSE}	V _{SS} - 0.3 to V _{SS} + 7.0	V
Regulator output voltage	V _{OUT}	V _{SS} - 0.3 to V _{IN} + 0.3	V
Detector output voltage	Nch open drain output CMOS output	V _{DOUT}	V _{SS} - 0.3 to V _{SS} + 7.0
		V _{DOUT}	V _{SS} - 0.3 to V _{IN} + 0.3
Power dissipation	P _D	400 ^{*1}	mW
Operation ambient temperature	T _{opr}	-40 to +85	°C
Storage temperature	T _{sta}	-40 to +125	°C

*1. When mounted on board

[Mounted board]

(1) Board size : 114.3 mm × 76.2 mm × t1.6 mm

(2) Board name : JEDEC STANDARD51-7

Caution The absolute maximum ratings are rated values exceeding which the product could suffer physical damage. These values must therefore not be exceeded under any conditions.

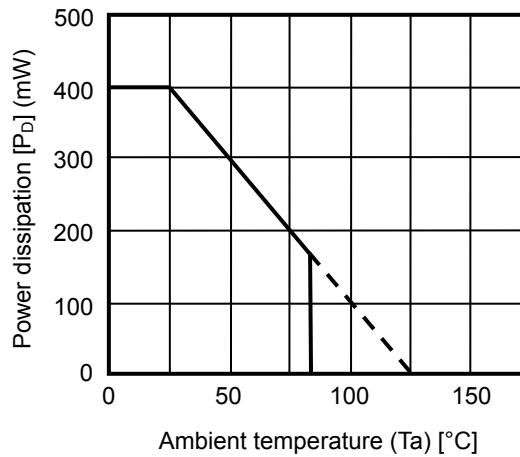

Figure 5 Power Dissipation of Package

■ Electrical Characteristics

1. Common to series (S-1702Axx to Hxx, Jxx to Nxx, Pxx)

Table 7 (1 / 2)

Entire circuit

(Ta = +25°C unless otherwise specified)

Item	Symbol	Condition	Min.	Typ.	Max.	Unit	Test Circuit
Current consumption during operation*1	I _{SS}	V _{IN} = V _{OUT(S)} + 1.0 V	–	10	18	μA	2

Regulator block

Item	Symbol	Condition	Min.	Typ.	Max.	Unit	Test Circuit	
Output voltage*2	V _{OUT(E)}	V _{IN} = V _{OUT(S)} + 1.0 V, I _{OUT} = 30 mA	V _{OUT(S)} × 0.99	V _{OUT(S)}	V _{OUT(S)} × 1.01	V	1	
Output current*3	I _{OUT}	V _{IN} > V _{OUT(S)} + 1.0 V	150*8	–	–	mA	3	
Dropout voltage*4	V _{drop}	I _{OUT} = 100 mA	1.5 V < V _{OUT(S)} ≤ 2.0 V	–	0.54	0.58	V	1
			2.0 V < V _{OUT(S)} ≤ 2.5 V	–	0.23	0.35	V	1
			2.5 V < V _{OUT(S)} ≤ 3.0 V	–	0.2	0.3	V	1
			3.0 V < V _{OUT(S)} ≤ 3.3 V	–	0.15	0.23	V	1
			3.3 V < V _{OUT(S)} ≤ 5.5 V	–	0.14	0.21	V	1
Line regulation	$\frac{\Delta V_{OUT1}}{\Delta V_{IN} \cdot V_{OUT}}$	V _{OUT(S)} + 0.5 V < V _{IN} < 6.5 V, I _{OUT} = 30 mA	–	0.05	0.2	%/V	1	
Load regulation	ΔV _{OUT2}	V _{IN} = V _{OUT(S)} + 1.0 V, 10 μA < I _{OUT} < 100 mA	–	20	40	mV	1	
Output voltage temperature coefficient*5	$\frac{\Delta V_{OUT}}{\Delta Ta \cdot V_{OUT}}$	V _{IN} = V _{OUT(S)} + 1.0 V, I _{OUT} = 30 mA, –40°C ≤ Ta ≤ +85°C*9	–	±100	±300	ppm/°C	1	
Current consumption during operation*1	I _{SS1}	V _{IN} = V _{OUT(S)} + 1.0 V, RESX and ON / OFF pins enabled for operation, no load	–	9	16	μA	2	
Input voltage	V _{IN}	–	2	–	6.5	V	–	
ON / OFF pin input voltage "H"	V _{SH1}	V _{IN} = V _{OUT(S)} + 1.0 V, R _L = 1.0 kΩ	1.2	–	–	V	4	
ON / OFF pin input voltage "L"	V _{SL1}	V _{IN} = V _{OUT(S)} + 1.0 V, R _L = 1.0 kΩ	–	–	0.3	V	4	
ON / OFF pin input current "H"	I _{SH1}	V _{IN} = 6.5 V, V _{ON / OFF} = 6.5 V	S-1702xxA	–0.1	–	0.1	μA	4
			S-1702xxD	–0.1	–	0.1	μA	4
			S-1702xxG	–0.1	–	0.1	μA	4
ON / OFF pin input current "L"	I _{SL1}	V _{IN} = 6.5 V, V _{ON / OFF} = 0 V	S-1702xxA	–0.1	–	0.1	μA	4
			S-1702xxD	–0.1	–	0.1	μA	4
			S-1702xxG	–0.1	–	0.1	μA	4
Ripple rejection	RR	V _{IN} = V _{OUT(S)} + 1.0 V, f = 1.0 kHz, ΔV _{rip} = 0.5 Vrms, I _{OUT} = 30 mA	1.5 V ≤ V _{OUT(S)} < 3.1 V	–	70	–	dB	5
			3.1 V ≤ V _{OUT(S)} ≤ 5.5 V	–	65	–	dB	5
Short-circuit current	I _{SHORT}	V _{IN} = V _{OUT(S)} + 1.0 V, ON / OFF pin enabled for operation, V _{OUT} = 0 V	–	300	–	mA	5	

Table 7 (2 / 2)

Detector block

(Ta = +25°C unless otherwise specified)

Item	Symbol	Condition	Min.	Typ.	Max.	Unit	Test Circuit	
Detection voltage*6	-V _{DET}	-	-V _{DET(S)} ×0.99	-V _{DET(S)}	-V _{DET(S)} ×1.01	V	6	
Hysteresis width	V _{HYS}	S-1702xAx, S-1702xBx, S-1702xCx	-V _{DET} ×0.035	-V _{DET} ×0.05	-V _{DET} ×0.065	V	6	
		S-1702xDx, S-1702Ex, S-1702xFx	-V _{DET} ×0.01	-V _{DET} ×0.025	-V _{DET} ×0.04	V	6	
		S-1702xGx, S-1702xHx, S-1702xJx	-	0	-V _{DET} ×0.015	V	6	
Current consumption during operation*1	I _{SS2}	1.3 V ≤ -V _{DET(S)} < 2.3 V	V _{IN} = -V _{DET(S)} + 1.5 V	-	2.4	4.0	μA	2
			V _{IN} = 5.5 V	-	2.6	4.5	μA	2
		2.3 V ≤ -V _{DET(S)} < 5.2 V	V _{IN} = -V _{DET(S)} + 1.5 V	-	2.2	3.5	μA	2
			V _{IN} = 5.5 V	-	2.3	4.0	μA	2
Input voltage	V _{IN}	-	0.8	-	6.5	V	-	
Detection voltage temperature coefficient*7	$\frac{\Delta -V_{DET}}{\Delta Ta \cdot -V_{DET}}$	Ta = -40°C to +85°C*9	-	±100	±400	ppm/ °C	6	

- *1. Excluding current flowing in pull-up and pull-down resistors connected to the ON / OFF or RESX pins
- *2. V_{OUT(S)}: Set output voltage
 V_{OUT(E)}: Actual output voltage at the fixed load
 The output voltage when fixing I_{OUT} (= 30 mA) and inputting V_{OUT(S)} + 1.0 V
- *3. The output current at which the output voltage becomes 95% of V_{OUT(E)} after gradually increasing the output current.
- *4. V_{drop} = V_{IN1} - (V_{OUT3} × 0.98)
 V_{OUT3} is the output voltage when V_{IN} = V_{OUT(S)} + 1.0 V and I_{OUT} = 100 mA.
 V_{IN1} is the input voltage at which the output voltage becomes 98% of V_{OUT3} after gradually decreasing the input voltage.
- *5. The change in temperature [mV/°C] of the regulator output voltage is calculated using the following equation.

$$\frac{\Delta V_{OUT}}{\Delta Ta} \text{ [mV/°C]}^{*1} = V_{OUT(S)} \text{ [V]}^{*2} \times \frac{\Delta V_{OUT}}{\Delta Ta \cdot V_{OUT}} \text{ [ppm/°C]}^{*3} \div 1000$$
 - *1. The change in temperature of the output voltage
 - *2. Set output voltage
 - *3. Output voltage temperature coefficient
- *6. -V_{DET(S)} : Set detection voltage
 -V_{DET} : Actual detection voltage
- *7. The change in temperature [mV/°C] of the detector detection voltage is calculated using the following equation.

$$\frac{\Delta -V_{DET}}{\Delta Ta} \text{ [mV/°C]}^{*1} = -V_{DET(S)} \text{ (Typ.) [V]}^{*2} \times \frac{\Delta -V_{DET}}{\Delta Ta \cdot -V_{DET}} \text{ [ppm/°C]}^{*3} \div 1000$$
 - *1. The change in temperature of the detection voltage
 - *2. Set detection voltage
 - *3. Detection voltage temperature coefficient
- *8. The output current can be at least this value.
 Due to restrictions on the package power dissipation, this value may not be satisfied. Attention should be paid to the power dissipation of the package when the output current is large. This specification is guaranteed by design.
- *9. Since products are not screened at high and low temperatures, the specification for this temperature range is guaranteed by design, not tested in production.

2. Discharge shunt circuit (discharge shunt function) (S-1702Axx, Bxx, Cxx, Exx, Fxx, Gxx, Jxx, Lxx, Nxx)

Table 8

(Ta = +25°C unless otherwise specified)

Item	Symbol	Condition	Min.	Typ.	Max.	Unit	Test Circuit
"L" output, Nch on resistor	R _{LOW}	V _{DS} = 0.5 V, V _{GS} = 6.5 V	–	100	–	Ω	3

3. Detector output circuit (VDOUT pin)

Table 9

Nch open drain output (S-1702xAx, xDx, xGx)

(Ta = +25°C unless otherwise specified)

Item	Symbol	Condition	Min.	Typ.	Max.	Unit	Test Circuit
Output current	I _{DOUT1}	Output transistor: Nch, V _{DS} = 0.5 V, V _{DD} = 1.2 V	1.36	2.55	–	mA	7
Leakage current	I _{LEAK}	Output transistor: Nch, V _{DS} = 5.5 V, V _{DD} = 5.5 V	–	–	100	nA	7

CMOS output (S-1702xBx, xCx, xEx, xFx, xHx, xJx)

Item	Symbol	Condition	Min.	Typ.	Max.	Unit	Test Circuit
Output current	I _{DOUT2}	Output transistor: Nch, V _{DS} = 0.5 V, V _{IN} = 1.2 V	1.36	2.55	–	mA	7
	I _{DOUT3}	Output transistor: Pch, V _{DS} = 0.5 V, V _{IN} = 5.5 V	1.71	2.76	–	mA	8

4. RESX pin (S-1702Axx, Bxx, Cxx, Dxx, Exx, Fxx, Gxx, Hxx)

Table 10

(Ta = +25°C unless otherwise specified)

Item	Symbol	Condition	Min.	Typ.	Max.	Unit	Test Circuit	
RESX pin input voltage "H" ^{*1}	V _{SH2}	V _{IN} = V _{OUT(S)} + 1.0 V, R _L = 1.0 kΩ	1.2	–	–	V	4	
RESX pin input voltage "L"	V _{SL2}	V _{IN} = V _{OUT(S)} + 1.0 V, R _L = 1.0 kΩ	–	–	0.3	V	4	
RESX pin input current "H"	I _{SH2}	V _{IN} = 6.5 V, V _{RESX} = 6.5 V	S-1702xxA	–0.1	–	0.1	μA	4
			S-1702xxB	–0.1	–	0.1	μA	4
			S-1702xxC	–0.1	–	0.1	μA	4
RESX pin input current "L"	I _{SL2}	V _{IN} = 6.5 V, V _{RESX} = 0 V	S-1702xxA	–0.1	–	0.1	μA	4
			S-1702xxB	–0.1	–	0.1	μA	4
			S-1702xxC	–0.1	–	0.1	μA	4

*1. V_{OUT(S)}: specified output voltage value

5. Pull-up / pull-down resistor value of ON / OFF pin and RESX pin (S-1702xxB, xxC, xxD, xxE, xxF, xxG, xxH, xxJ)

Table 11

(Ta = +25°C unless otherwise specified)

Item	Symbol	Condition	Min.	Typ.	Max.	Unit	Test Circuit
Pull-up / pull-down resistor	R _{PULL}	–	–	2.0	–	MΩ	4

6. Response time

Table 12

Internal delay type (S-1702Axx, Bxx, Cxx, Dxx, Exx, Fxx, Gxx, Hxx, Jxx, Kxx) (Ta = +25°C unless otherwise specified)

Item	Symbol	Condition	Min.	Typ.	Max.	Unit	Test Circuit
Response time	T _{PLH1}	–	–	–	90	μs	6

External delay type (S-1702Lxx, Mxx, Nxx, Pxx)

Item	Symbol	Condition	Min.	Typ.	Max.	Unit	Test Circuit
Response time	T _{PLH2}	C _D = 4.7 nF	–	30	–	ms	9

■ Test Circuits

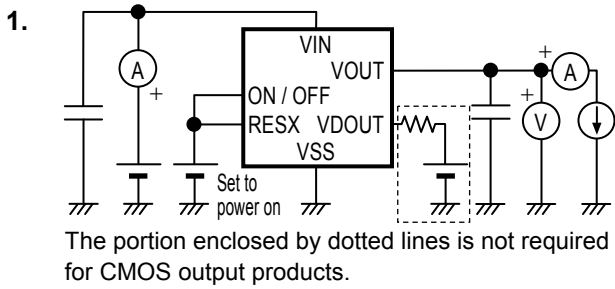

Figure 6

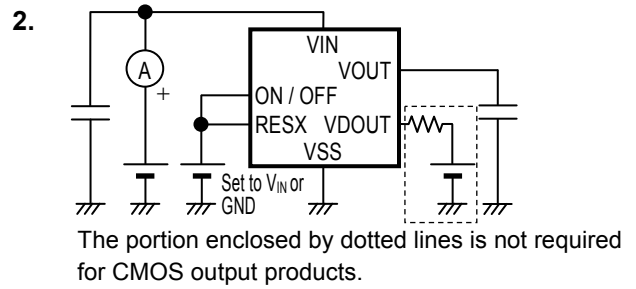

Figure 7

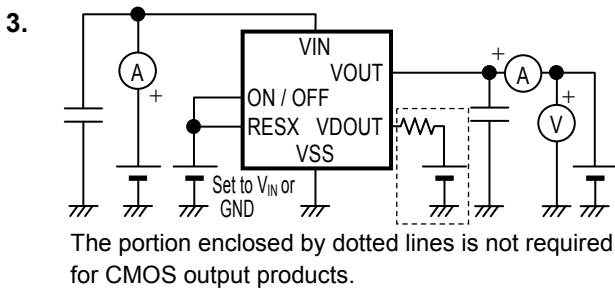

Figure 8

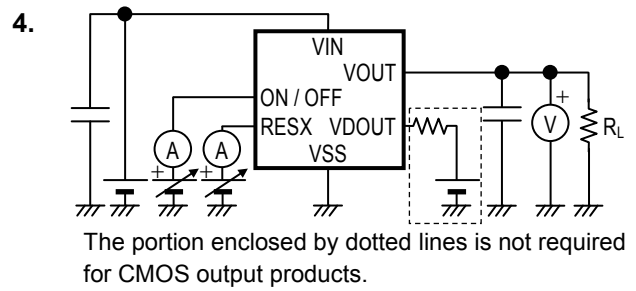

Figure 9

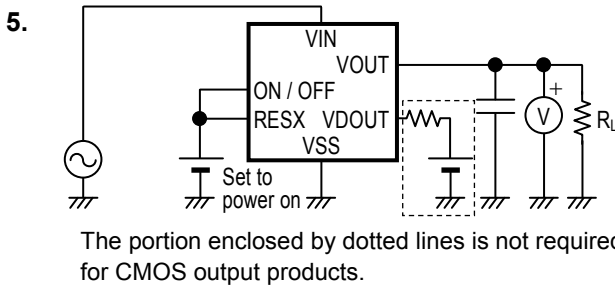

Figure 10

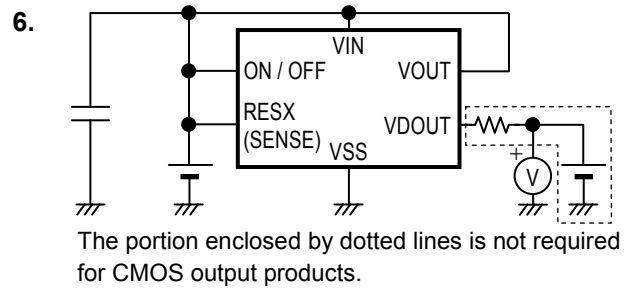

Figure 11

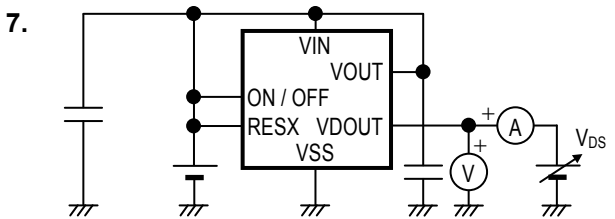

Figure 12

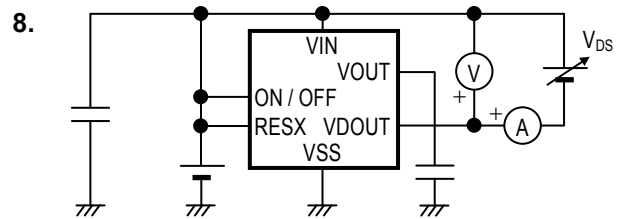

Figure 13

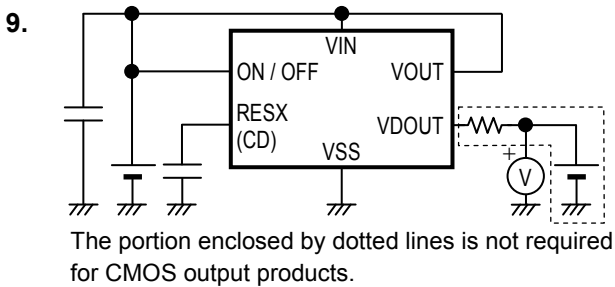
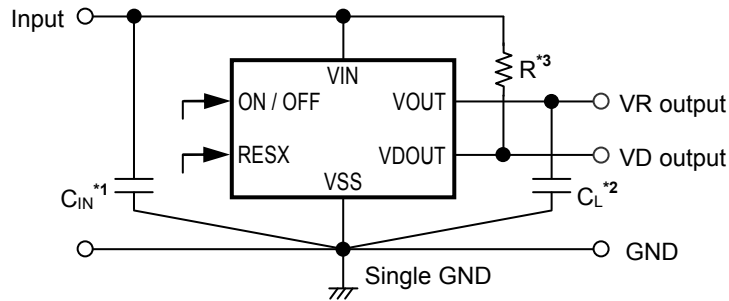

Figure 14

■ **Standard Circuits**

1. **S-1702Axx, Bxx, Cxx, Dxx, Exx, Fxx, Gxx, Hxx**



- *1. C_{IN} is a capacitor for stabilizing the input.
- *2. A ceramic capacitor of 1.0 μF or more can be used for C_L .
- *3. R is not required for a CMOS output product.

Figure 15

2. **S-1702Jxx, Kxx**

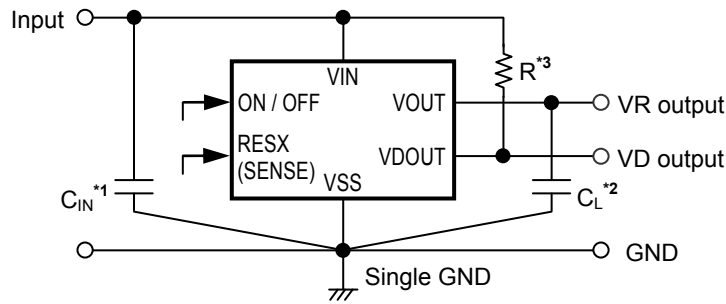

- *1. C_{IN} is a capacitor for stabilizing the input.
- *2. A ceramic capacitor of 1.0 μF or more can be used for C_L .
- *3. R is not required for a CMOS output product.

Figure 16

3. **S-1702Lxx, Mxx, Nxx, Pxx**

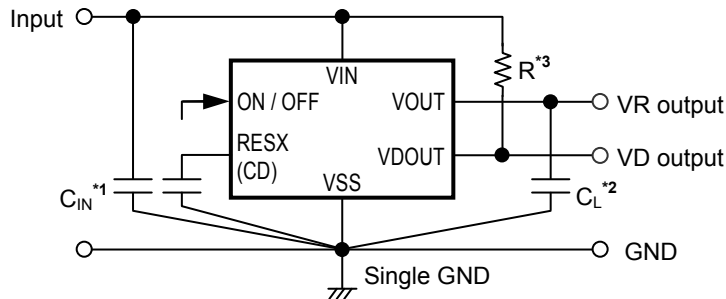

- *1. C_{IN} is a capacitor for stabilizing the input.
- *2. A ceramic capacitor of 1.0 μF or more can be used for C_L .
- *3. R is not required for a CMOS output product.

Figure 17

Caution The above connection diagrams and constants will not guarantee successful operation. Perform thorough evaluation using the actual application to set the constants.

■ Application Conditions

Input capacitor (C_{IN}):	1.0 μ F or more
Output capacitor (C_L):	1.0 μ F or more
ESR of output capacitor:	10 Ω or less

Caution Generally a series regulator may cause oscillation, depending on the selection of external parts. Confirm that no oscillation occurs in the application for which the above capacitors are used.

■ Selection of VIN Input and VOUT Output Capacitors (C_{IN} , C_L)

The S-1702 Series requires an output capacitor (C_L) between the VOUT and VSS pins for phase compensation. A ceramic capacitor with a capacitance of 1.0 μ F or more provides a stable operation in all temperature ranges. When using an OS capacitor, tantalum capacitor, or aluminum electrolytic capacitor, a capacitor with a capacitance of 1.0 μ F or more and an ESR of 10 Ω or less is required.

The output overshoot and undershoot values, which are transient response characteristics, vary depending on the output capacitor value. The required capacitance value for the input capacitor differs depending on the application.

The recommended application values are $C_{IN} = 1.0 \mu\text{F}$ or more and $C_L = 1.0 \mu\text{F}$ or more; however, perform thorough evaluation using the actual device, including evaluation of temperature characteristics.

■ Explanation of Terms

1. Regulator block

1.1 Low dropout voltage regulator

This voltage regulator has the low dropout voltage due to its built-in transistor with low on-resistance.

1.2 Low ESR

A capacitor whose ESR (Equivalent Series Resistance) is low. The S-1702 Series enables use of a low ESR capacitor, such as a ceramic capacitor, for the output-side capacitor (C_L). A capacitor whose ESR is 10 Ω or less can be used.

1.3 Output voltage (V_{OUT})

The accuracy of the output voltage is ensured at $\pm 1.0\%$ under the specified conditions of fixed input voltage^{*1}, fixed output current, and fixed temperature.

*1. Differs depending on the product.

Caution If the above conditions change, the output voltage may vary and exceed the accuracy range of the output voltage. Refer to “■ Electrical Characteristics” and “■ Characteristics (Typical Data)” for details.

1.4 Line regulation $\left(\frac{\Delta V_{OUT1}}{\Delta V_{IN} \bullet V_{OUT}} \right)$

Indicates the dependency of the output voltage on the input voltage. That is, the values show how much the output voltage changes due to a change in the input voltage with the output current remaining unchanged.

1.5 Load regulation (ΔV_{OUT2})

Indicates the dependency of the output voltage on the output current. That is, the values show how much the output voltage changes due to a change in the output current with the input voltage remaining unchanged.

1.6 Dropout voltage (V_{drop})

Indicates the difference between the input voltage V_{IN1} , which is the input voltage (V_{IN}) at the point where the output voltage has fallen to 98% of the output voltage value V_{OUT3} after V_{IN} was gradually decreased from $V_{IN} = V_{OUT(S)} + 1.0$ V, and the output voltage at that point ($V_{OUT3} \times 0.98$).

$$V_{drop} = V_{IN1} - (V_{OUT3} \times 0.98)$$

1.7 Output voltage temperature coefficient $\left(\frac{\Delta V_{OUT}}{\Delta T_a \bullet V_{OUT}} \right)$

The shaded area in **Figure 18** is the range where V_{OUT} varies in the operating temperature range when the output voltage temperature coefficient is ± 100 ppm/ $^{\circ}\text{C}$.

(Refer to *5 of **Table 7** for how to calculate the temperature change [mV/ $^{\circ}\text{C}$] of the output voltage.)

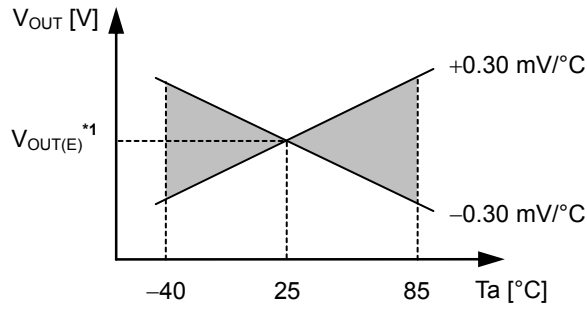

*1. $V_{OUT(E)}$ is the value of the output voltage measured at 25°C .

Figure 18 Example of Output Voltage Temperature Characteristics (When $V_{OUT} = 3.0 \text{ V Typ.}$)

2. Detector block

2.1 Detection voltage ($-V_{DET}$)

The detection voltage ($-V_{DET}$) is a voltage when the detector output voltage (V_{DOUT}) switches to low. This detection voltage varies slightly depending on products even having the same specification. The range between the minimum ($-V_{DET}$) value and the maximum ($-V_{DET}$) value due to variation is called the range of detection voltage (refer to **Figure 19**).

e.g. In a product with $-V_{DET} = 3.0$ V, the detection voltage is a value in the range of 2.97 V $\leq (-V_{DET}) \leq 3.03$ V.
 This means that some products have 2.97 V for $-V_{DET}$ and some have 3.03 V.

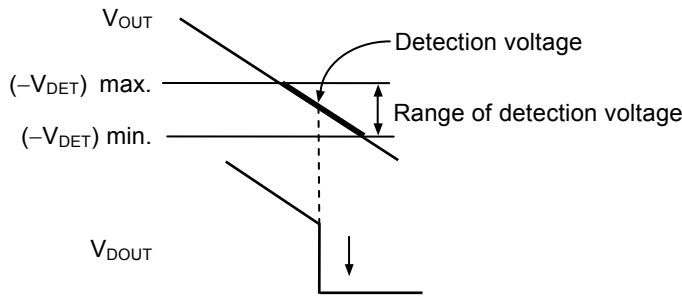

Remark This is the case when the regulator output voltage (V_{OUT}) is monitored by the detector.

Figure 19 Detection Voltage ($-V_{DET}$)

2.2 Release voltage ($+V_{DET}$)

The release voltage ($+V_{DET}$) is a voltage when the detector output voltage (V_{DOUT}) switches to high. This release voltage varies slightly depending on products even having the same specification. The range between the minimum ($+V_{DET}$) value and the maximum ($+V_{DET}$) value due to variation is called the range of release voltage (refer to **Figure 20**).

e.g. In a product with $-V_{DET} = 3.0$ V and hysteresis width of 5%, the release voltage is a value in the range of 3.074 V $\leq (+V_{DET}) \leq 3.227$ V.
 This means that some products have 3.074 V for $+V_{DET}$ and some have 3.227 V.

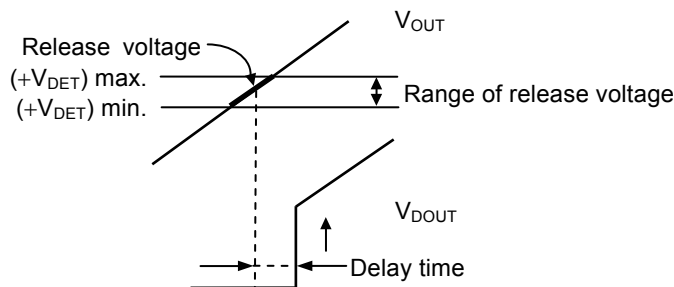

Remark This is the case when the regulator output voltage (V_{OUT}) is monitored by the detector.

Figure 20 Release Voltage ($+V_{DET}$)

2.3 Hysteresis width (V_{HYS})

The hysteresis width is the difference between the detection voltage and the release voltage. Setting the hysteresis width prevents malfunction caused by noise on the input voltage. The hysteresis width is internally fixed and varies depending on the product type (refer to **Table 2**).

2.4 Delay time (t_D)

The delay time (t_D) is a period from the input voltage flowing to the detector block has exceeded the release voltage ($+V_{DET}$), until the detector output voltage (V_{DOUT}) inverts.

The internal delay type products (S-1702Axx, Bxx, Cxx, Dxx, Exx, Fxx, Gxx, Hxx, Jxx, Kxx) have delay time which is internally fixed.

In external delay type products (S-1702Lxx, Mxx, Nxx, Pxx), the delay time (t_D) can be changed by controlling the capacitance value of the capacitor (C_D) connected between the CD (RESX) and VSS pins.

For how to set the delay time (t_D), refer to “**3.2 Delay circuit**” in “**3. Detector block**” in “**■ Operation**”.

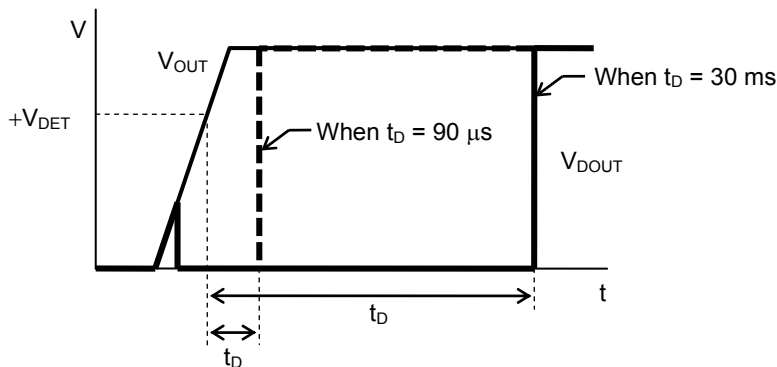

Remark This is the case when the regulator output voltage (V_{OUT}) is monitored by the detector.

Figure 21

2.5 Through-type current

This is the current that flows instantaneously when the voltage detector detects and releases a voltage.

A large through-type current flows in CMOS output products (S-1702xBx, xCx, xEx, xFx, xHx, xJx).

A small through-type current flows in Nch open drain products (S-1702xAx, xDx, xGx).

2.6 Oscillation

In applications where a resistor is connected to the input side (**Figure 22**), the through-type current which is generated when the detector output voltage (V_{DOUT}) goes from low to high (release) causes a voltage drop equal to Through-type current \times Input resistance across the resistor. When the input voltage drops below the detection voltage as a result, the detector output voltage (V_{DOUT}) goes from high to low. In this state, the through-type current stops, its resultant voltage drop disappears, and the detector output voltage (V_{DOUT}) goes from low to high. The through-type current is then generated again, a voltage drop appears, and repeating the process finally induces oscillation.

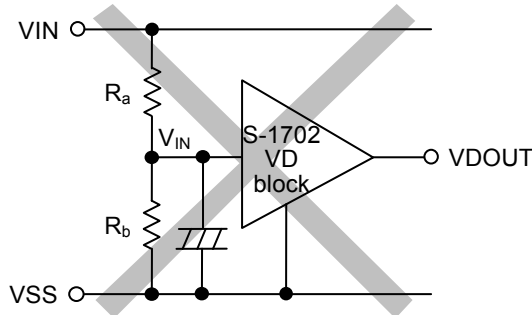

Figure 22 Example of Bad Implementation of Detection Voltage Changer

2.7 Temperature characteristics of detection voltage

The shaded area in **Figure 23** is the range where $-V_{DET}$ varies within the operating temperature range when the temperature coefficient of the detection voltage is ± 100 ppm/ $^{\circ}C$. (Refer to *7 of **Table 7** for how to calculate the temperature change [mV/ $^{\circ}C$] of the detection voltage.)

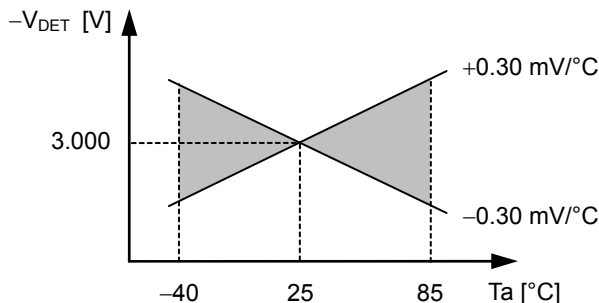

Figure 23 Example of Detection Voltage Temperature Characteristics (When $-V_{DET} = 3.0$ V Typ.)

2.8 Temperature characteristics of release voltage

The temperature change $\frac{\Delta + V_{DET}}{\Delta Ta}$ of the release voltage is calculated by the temperature change $\frac{\Delta - V_{DET}}{\Delta Ta}$

of the detection voltage as follows:

$$\frac{\Delta + V_{DET}}{\Delta Ta} = \frac{+V_{DET}}{-V_{DET}} \times \frac{\Delta - V_{DET}}{\Delta Ta}$$

The temperature changes of the release voltage and the detection voltage consequently have the same sign.

2.9 Temperature characteristics of hysteresis voltage

The temperature change of the hysteresis voltage is expressed as $\frac{\Delta + V_{DET}}{\Delta Ta} - \frac{\Delta - V_{DET}}{\Delta Ta}$ and is calculated as follows:

$$\frac{\Delta + V_{DET}}{\Delta Ta} - \frac{\Delta - V_{DET}}{\Delta Ta} = \frac{V_{HYS}}{-V_{DET}} \times \frac{\Delta - V_{DET}}{\Delta Ta}$$

■ Operation

1. Control of S-1702 Series by using ON / OFF and RESX pins

1.1 Starting and stopping regulator block

The regulator block can be started and stopped according to the combination of the ON / OFF and RESX pins.

The regulator block switches off the output transistor between the VIN and VOUT pins and reduces current consumption significantly.

The detector block is operating during this period, so only the amount of current consumed by the detector block flows in the S-1702 Series.

1.2 Regulator output (V_{OUT}) control: discharge shunt function *1

The regulator output (V_{OUT}) can be controlled by combining the ON / OFF and RESX pins.

In the product types having a discharge shunt circuit*1 (Axx, Bxx, Cxx, Exx, Fxx, Gxx, Jxx, Lxx, Nxx), this circuit forcibly sets the regulator output (V_{OUT}) the V_{SS} level*1.

In the product types that do not have a discharge shunt circuit*1 (Dxx, Hxx, Kxx, Mxx, Pxx), the regulator output (V_{OUT}) is set at the V_{SS} level by a division resistor of several $M\Omega$ between the VOUT and VSS pins.

*1. For details of a discharge shunt circuit, refer to “2. 2. 2 Discharge shunt function” in “2. Regulator Block”.

1.3 Detector output voltage (V_{DOUT}) control: forcible assertion function

The detector output voltage (V_{DOUT}) is forcibly asserted to the V_{SS} level by combining the ON / OFF and RESX pins.

When the forcible assertion function is not being used, the result of detection by the detector (release status: “H”, detection status: “L”) is output from the VDOUT pin.

1.4 Operation of each function according to ON / OFF and RESX pins

The following shows the operation of each function according to the combination of the ON / OFF and RESX pin.

Table 13

S-1702Axx, Exx

ON / OFF Pin	RESX Pin	Regulator Block	Regulator Output (V _{OUT})	Detector Output (V _{DOUT})
"L"	"L"	Stops	Forcibly discharged	V _{SS} potential
"L"	"H"	Stops	Forcibly discharged	V _{SS} potential
"H"	"L"	Stops	Forcibly discharged	V _{SS} potential
"H"	"H"	Starts	Set value	"H" or "L"

S-1702Bxx, Fxx

ON / OFF Pin	RESX Pin	Regulator Block	Regulator Output (V _{OUT})	Detector Output (V _{DOUT})
"L"	"L"	Stops	Forcibly discharged	V _{SS} potential
"L"	"H"	Stops	Forcibly discharged	V _{SS} potential
"H"	"L"	Starts	Set value	V _{SS} potential
"H"	"H"	Starts	Set value	"H" or "L"

S-1702Cxx, Gxx

ON / OFF Pin	RESX Pin	Regulator Block	Regulator Output (V _{OUT})	Detector Output (V _{DOUT})
"L"	"L"	Stops	Forcibly discharged	V _{SS} potential
"L"	"H"	Stops	Not forcibly discharged	"H" or "L"
"H"	"L"	Stops	Forcibly discharged	V _{SS} potential
"H"	"H"	Starts	Set value	"H" or "L"

S-1702Dxx, Hxx

ON / OFF Pin	RESX Pin	Regulator Block	Regulator Output (V _{OUT})	Detector Output (V _{DOUT})
"L"	"L"	Stops	Not forcibly discharged	V _{SS} potential
"L"	"H"	Stops	Not forcibly discharged	"H" or "L"
"H"	"L"	Starts	Set value	V _{SS} potential
"H"	"H"	Starts	Set value	"H" or "L"

S-1702Jxx, Lxx, Nxx

ON / OFF Pin	Regulator Block	Regulator Output (V _{OUT})	Detector Output (V _{DOUT})
"L"	Stops	Forcibly discharged	V _{SS} potential
"H"	Starts	Set value	"H" or "L"

S-1702Kxx, Mxx, Pxx

ON / OFF Pin	Regulator Block	Regulator Output (V _{OUT})	Detector Output (V _{DOUT})
"L"	Stops	Not forcibly discharged	"H" or "L"
"H"	Starts	Set value	"H" or "L"

1.5 Equivalent circuits of ON / OFF and RESX pins

The ON / OFF and RESX pins are internally fixed to any one of three states; pulled-up (via a pull-up resistor), pulled-down (via a pull-down resistor), or neither pulled-up nor pulled-down (no down pull-up / pull-down resistor). For details, refer to “Table 3 Input Types of RESX and ON / OFF Pins”. The equivalent circuits are shown below.

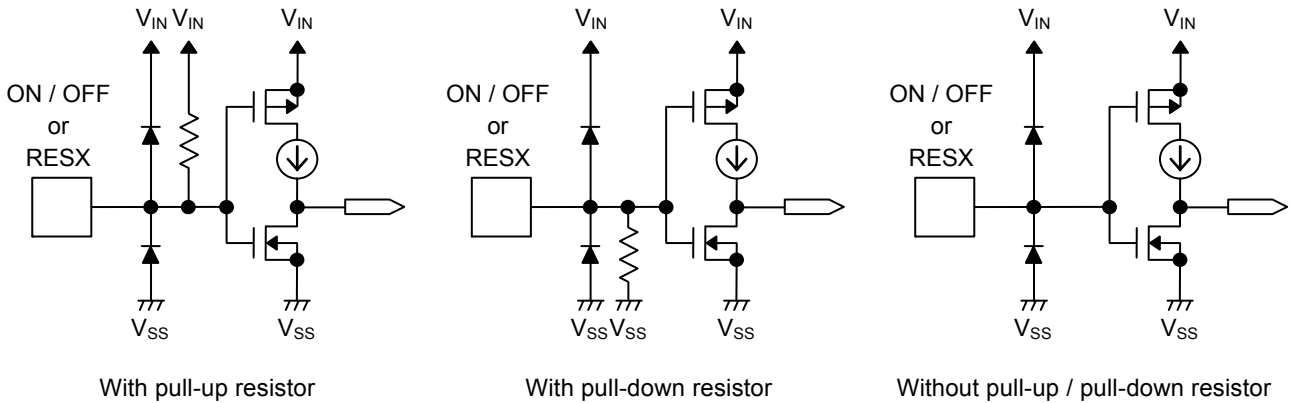

Figure 24 Equivalent Circuits of ON / OFF and RESX Pins

Caution In product without pull-up / pull-down resistor, do not use the ON / OFF and RESX pins in a floating state.
 Note that applying voltage of 0.3 V to 1.2 V may increase current consumption.

2. Regulator block

2.1 Basic operation

The error amplifier compares the reference voltage (V_{ref}) with V_{fb} , which is the output voltage resistance divided by feedback resistors R_s and R_f . It supplies the output transistor with the gate voltage necessary to ensure a certain output voltage free of any fluctuations of input voltage and temperature.

The regulator output voltage (V_{OUT}) of the S-1702 Series can be selected from a value between 1.5 V and 5.5 V. The block diagram of the regulator block is shown below.

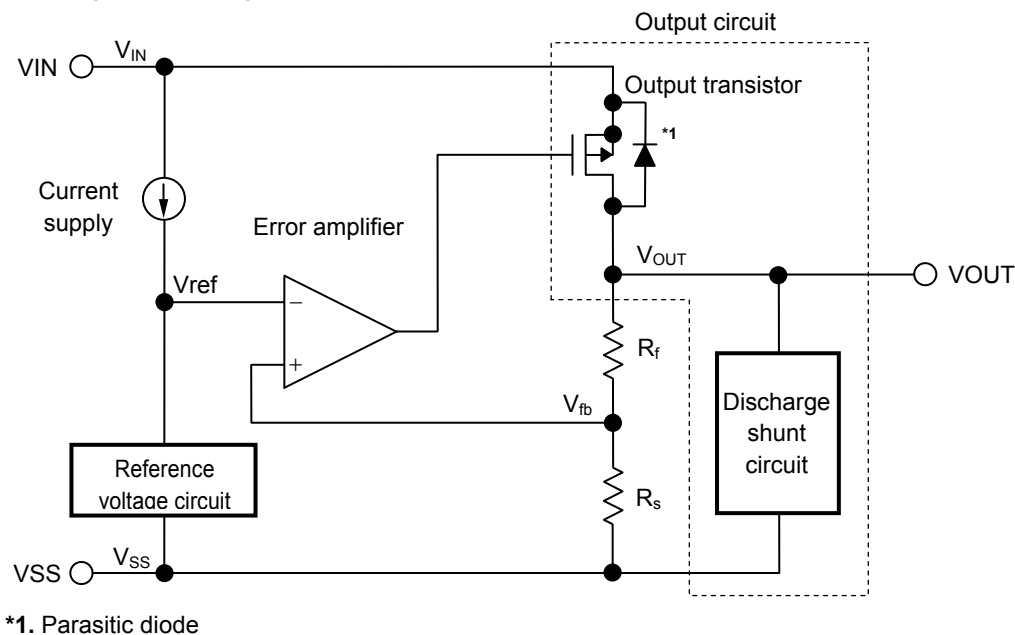
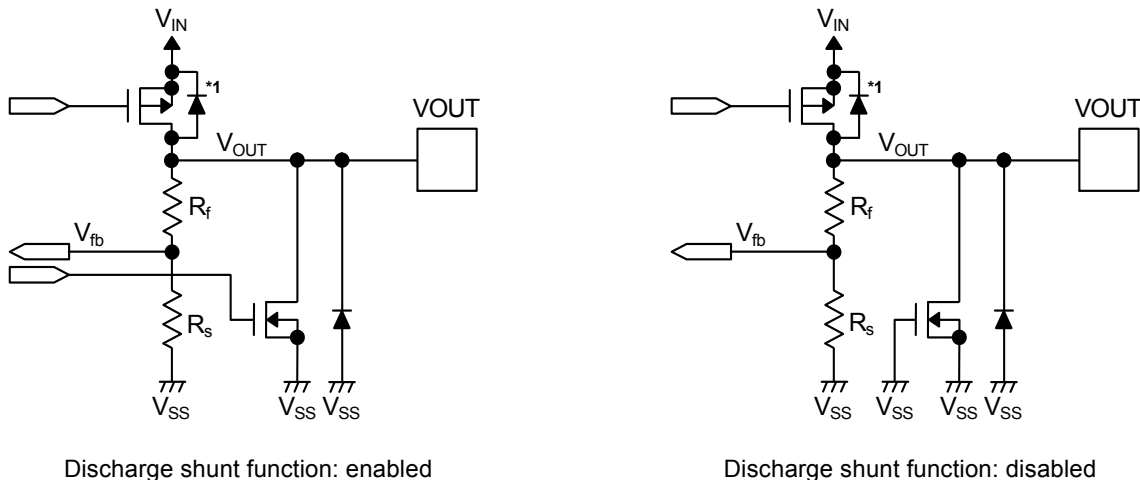

Figure 25 Block Diagram (Regulator Block)

2.2 Output circuit

The output circuit of the regulator block consists of an output transistor and a discharge shunt circuit. The discharge shunt function is enabled or disabled for the VOUT pin. Refer to “Table 1 Product Types” for details. The equivalent circuits are shown below.



*1. Parasitic diode

Figure 26 Equivalent Circuits of VOUT Pin

2. 2. 1 Output transistor

The S-1702 Series regulator block uses a low on-resistance Pch MOSFET transistor as the output transistor.

Caution Be sure that V_{OUT} does not exceed $V_{IN} + 0.3 V$ to prevent the voltage regulator from being damaged due to inverse current flowing from the VOUT pin through a parasitic diode to the VIN pin.

2. 2. 2 Discharge shunt function

The discharge shunt function is enabled in the S-1702Axx, Bxx, Cxx, Exx, Fxx, Gxx, Jxx, Lxx, and Nxx. When the regulator block is stopped, the output transistor is turned off and the discharge shunt circuit is turned on according to the combination of the ON / OFF and the RESX pins.

This operation causes the charge in the output capacitor (C_L) to be discharged, and forcibly sets the VOUT pin the V_{SS} level.

The VOUT pin is set at the V_{SS} level in a shorter time than the S-1702Dxx, Hxx, Kxx, Mxx, and Pxx, because they disable the discharge shunt function.

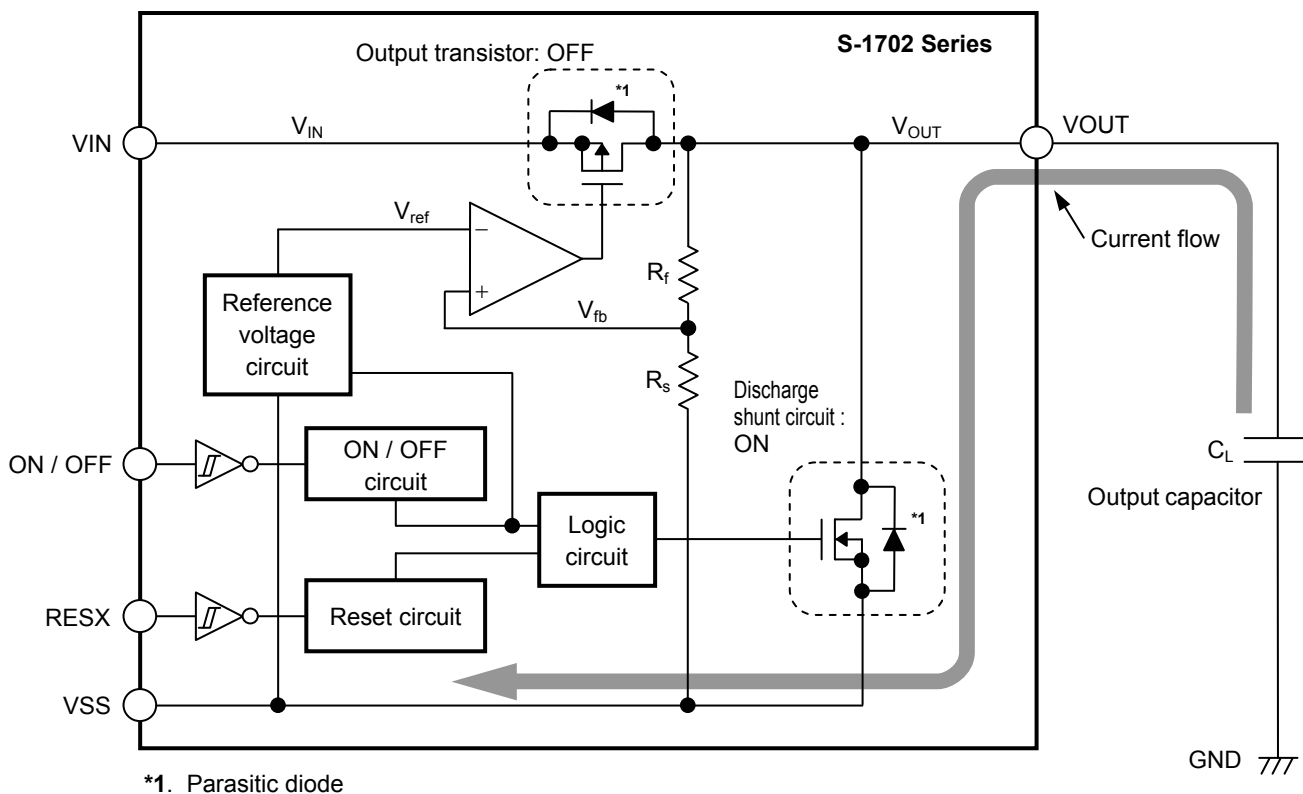

*1. Parasitic diode

Figure 27 Discharge Shunt Function

3. Detector block

3.1 Basic operation

Figure 28 shows a block diagram of the detector block.

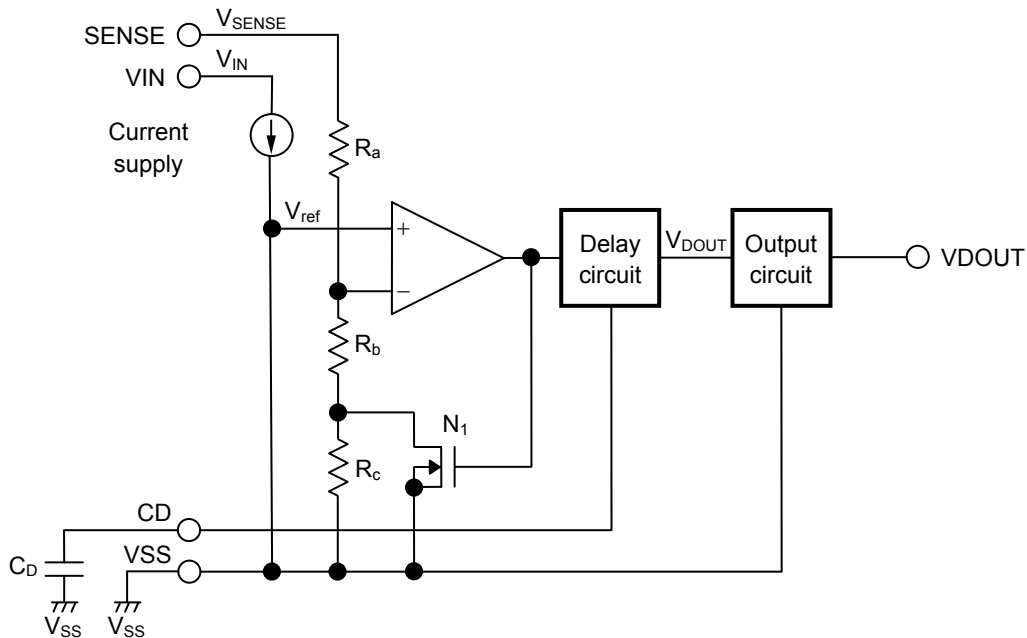

Figure 28 Block Diagram (Detector Block)

- (1) When the SENSE voltage (V_{SENSE}) is the release voltage ($+V_{DET}$) or more, the VDOUT pin outputs “H”. ((1) in **Figure 29**)

In this case, the transistor (N_1) is off and the input voltage to the comparator is $\frac{(R_b + R_c) \cdot V_{SENSE}}{R_a + R_b + R_c}$.

- (2) Although the SENSE voltage (V_{SENSE}) drops to the release voltage ($+V_{DET}$) or less, the VDOUT pin outputs “H” when the SENSE voltage (V_{SENSE}) is the detection voltage ($-V_{DET}$) or more. If the SENSE voltage (V_{SENSE}) is the detection voltage ($-V_{DET}$) or less (refer to point **A** in **Figure 29**), the VDOUT pin outputs “L” ((2) in **Figure 29**).

The transistor (N_1) is turned on and the input voltage to the comparator is $\frac{R_b \cdot V_{SENSE}}{R_a + R_b}$.

- (3) If the VIN input voltage (V_{IN}) further drops to the lowest operating voltage of the S-1702 Series, the VDOUT pin is sets in high impedance. If the VDOUT pin is pulled up to the regulator output voltage (V_{OUT}), the VDOUT pin outputs V_{OUT} (“H”) ((3) in **Figure 29**).
- (4) If the VIN input voltage (V_{IN}) rises to the lowest operating voltage or more, the VDOUT pin outputs “L”. Although the SENSE voltage (V_{SENSE}) exceeds the detection voltage ($-V_{DET}$), it is the release voltage ($+V_{DET}$) or less, the VDOUT pin outputs “L” ((4) in **Figure 29**).
- (5) If the SENSE voltage (V_{SENSE}) rises to the release voltage ($+V_{DET}$) or more (see point **B** in **Figure 29**), the VDOUT pin outputs “H”. The VDOUT pin outputs “H” after it is delayed for t_D by the delay circuit ((5) in **Figure 29**).

In the S-1702 Series, the detection voltage (V_{DOUT}) can be set within the range of 1.3 V to 5.2 V (operating voltage range: $V_{IN} = 0.8$ V to 6.5 V).

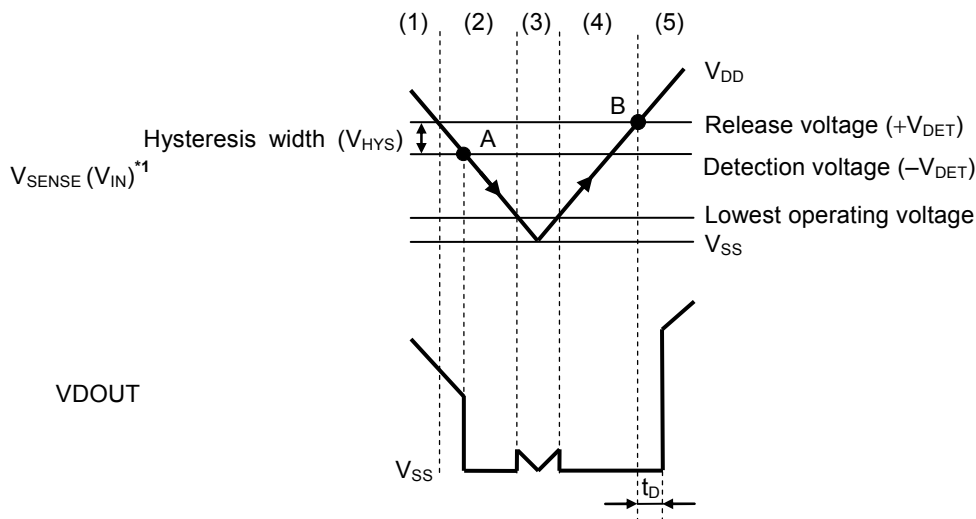

*1. When the SENSE pin is connected to the VIN pin.

Figure 29 Operation

3. 1. 1 Regulator output voltage (V_{OUT}) detection types (S-1702Axx, Bxx, Cxx, Dxx, Lxx, Mxx)

Each detector block of S-1702Axx, Bxx, Cxx, Dxx, Lxx, and Mxx detects the regulator output voltage (V_{OUT}).

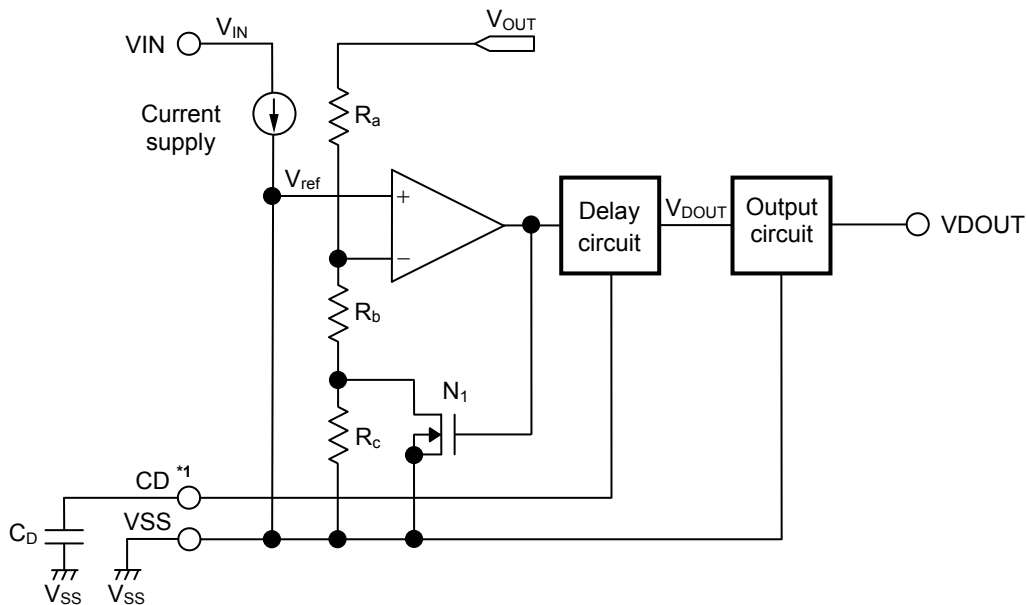

*1. S-1702Lxx and S-1702Mxx only

Figure 30 Block Diagram (Regulator Output Voltage (V_{OUT}) Detection Type)

Caution If the input voltage or load current changes transiently, undershoot or overshoot occurs in the regulator output voltage (V_{OUT}). In the product types that the regulator output voltage is detected by the detector, if the output voltage reaches the detection voltage or less due to undershoot, the detector operates so that a reset signal may be output. To prevent this, set the value of the capacitor so that the value of undershoot is the minimum, or set the voltage range in which the difference of the output voltage and the detection voltage is undershoot or more.

3. 1. 2 Input voltage (V_{IN}) detection types (S-1702Exx, Fxx, Gxx, Hxx, Nxx, Pxx)

Each detector block of S-1702Exx, Fxx, Gxx, Hxx, Nxx, and Pxx detects the input voltage (V_{IN}).

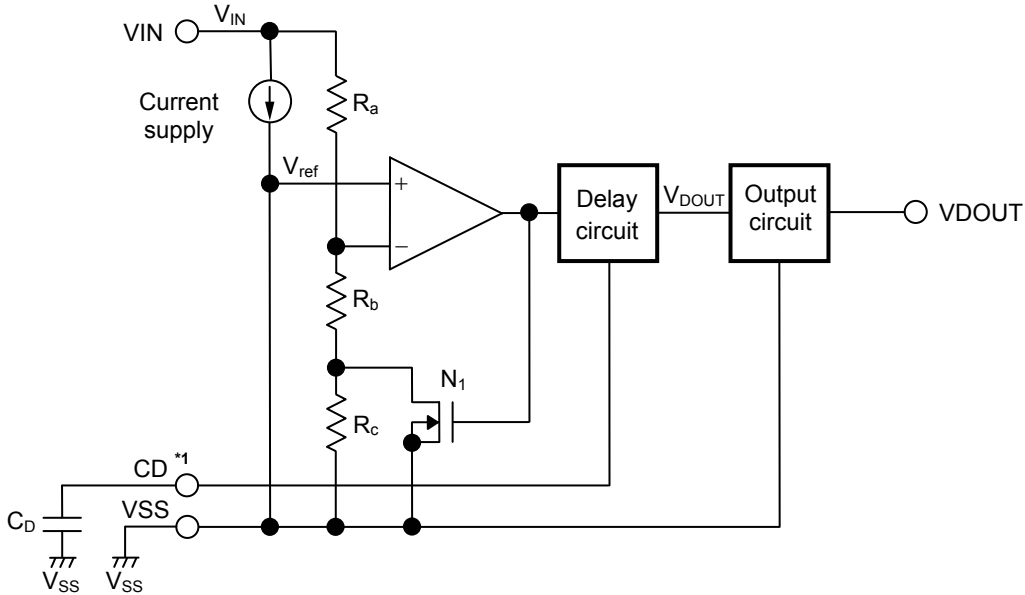

*1. S-1702Nxx and S-1702Pxx only

Figure 31 Block Diagram (Input Voltage (V_{IN}) Detection Type)

3. 1. 3 SENSE voltage (V_{SENSE}) detection types (S-1702Jxx, Kxx)

Each detector block of S-1702Jxx and Kxx detects the SENSE voltage (V_{SENSE}).

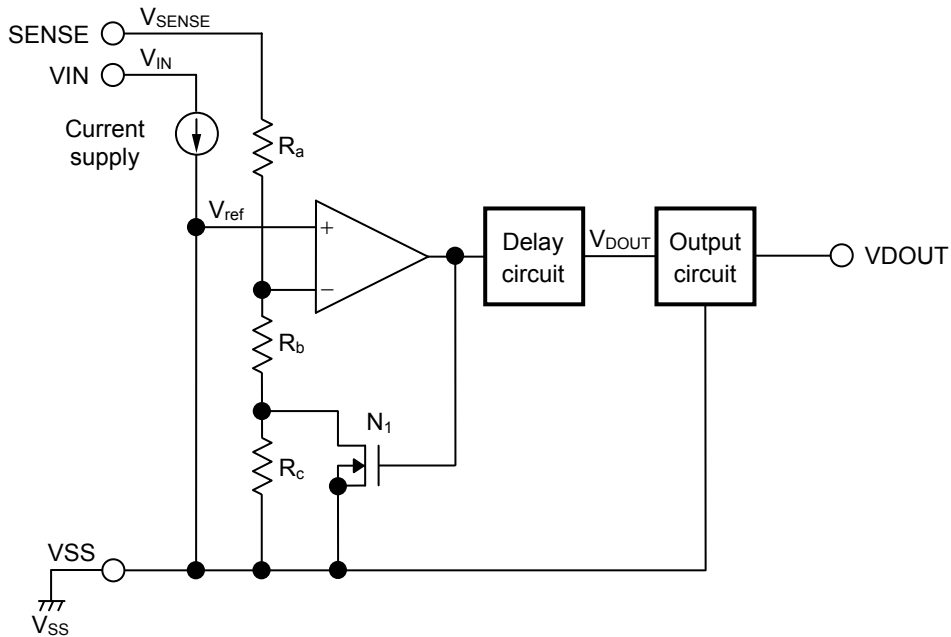

Figure 32 Block Diagram (SENSE Voltage (V_{SENSE}) Detection Type)

Caution Use the SENSE pin as an input pin when detecting the external power supply voltage. If applying an input voltage (V_{IN}) while a potential is being applied to the SENSE pin, an error occurs in the release voltage of the detector. Apply a voltage to the SENSE pin after applying the input voltage (V_{IN}).

3.2 Delay circuit

3.2.1 Internal delay types (S-1702Axx, Bxx, Cxx, Dxx, Exx, Fxx, Gxx, Hxx, Jxx, Kxx)

In the internal delay types, when V_{SENSE} is turned on, the delay circuit makes a certain delay, after the point when V_{SENSE} has reached the release voltage ($+V_{DET}$), and sets the V_{DOUT} pin to output an output signal (refer to point **B** in **Figure 29**). The delay circuit does not make delay when V_{SENSE} is the detection voltage ($-V_{DET}$) or less (refer to point **A** in **Figure 29**).

The delay time (t_D) is fixed in the internal circuit of internal delay types.

3.2.2 External delay types (S-1702Lxx, Mxx, Nxx, Pxx)

In the external delay types, the delay time of the detection signal can be set by connecting a capacitor (C_D) between the CD and V_{SS} pins.

The delay time (t_D) is determined according to the built-in constant current, approx. 100 nA (typ.), and the time constant of the external capacitor (C_D), and can be calculated by the following equation.

$$t_D [\text{ms}] = \text{Delay constant} \times C_D [\text{nF}]$$

The delay constant ($T_a = +25^\circ\text{C}$) is as follows.

Delay constant: 5.3 (min.), 6.3 (typ.), 7.3 (max.)

Figure 33 shows the equivalent circuit of the CD pin (external delay type).

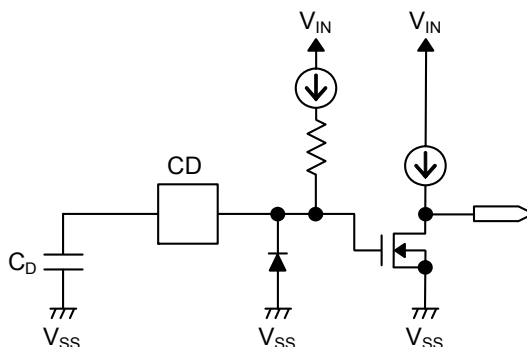
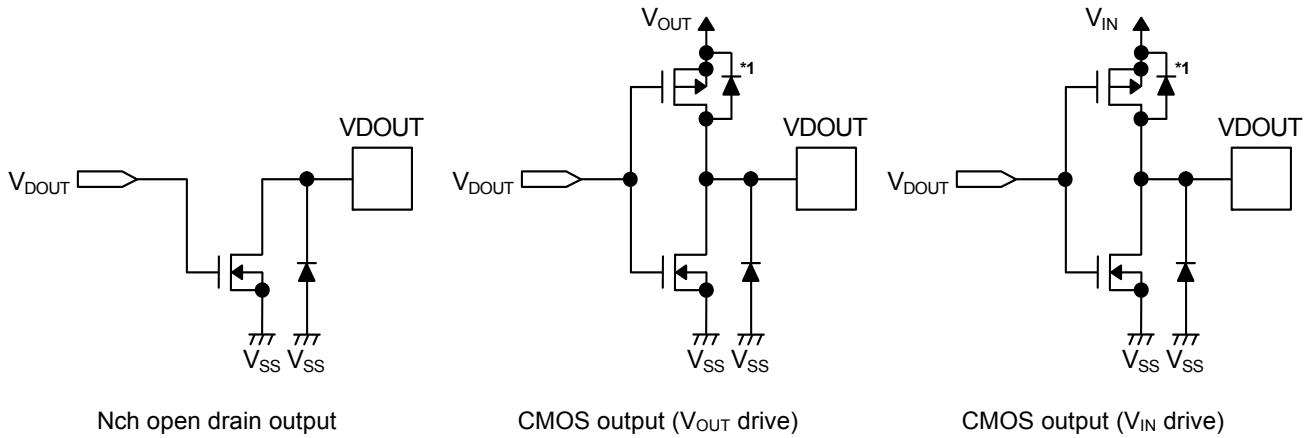

Figure 33 Equivalent Circuit of CD Pin (External Delay Type)

- Caution**
1. Design the board so that a current will not flow into or flow out from the CD (RESX) pin, because this pin's impedance is high. (Otherwise that may provide incorrect delay time.)
 2. There is no limit for the capacitance of the external capacitor (C_D) as long as the leakage current of the capacitor can be ignored against the built-in constant current value. Leakage current causes deviation in delay time. When the leakage current is the built-in constant current or more, the IC does not release.

3.3 Output Circuit

Either Nch open drain output, CMOS output (V_{OUT} drive), or CMOS output (V_{IN} drive) is used for the VDOUT pin. For details, refer to “Table 2 Output Types of VDOUT Pin”. The equivalent circuits are shown below.



*1. Parasitic diode

Figure 34 Equivalent Circuits of VDOUT Pin

4. Relation of temperature coefficients of detector and regulator blocks

The S-1702 Series has a detector and a regulator in it, and each reference voltage circuit has the same structure so that both temperature coefficients of detector detection voltage and regulator output interlock.

4.1 Positive temperature coefficient of regulator output

If the temperature coefficient of regulator output is positive, so is that of detector detection voltage (Figure 35).

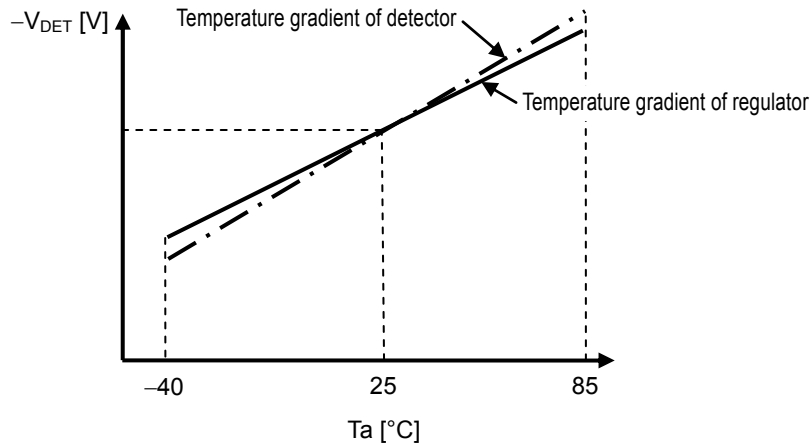

Figure 35 Relation of Temperature Coefficients of Detector and Regulator (When They Are Positive)

4.2 Negative temperature coefficient of regulator output

If the temperature coefficient of regulator output is negative, so is that of detector detection voltage (Figure 36).

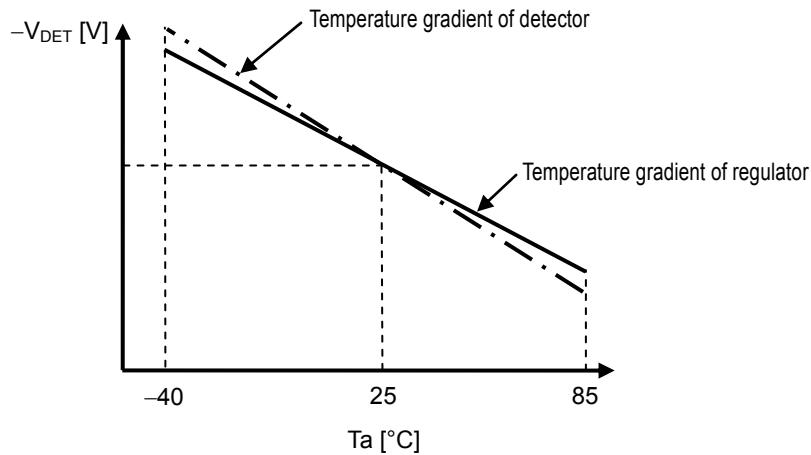

Figure 36 Relation of Temperature Coefficients of Detector and Regulator (When They Are Negative)

■ Precautions

- Wiring patterns for the VIN, VOUT and GND pins should be designed so that the impedance is low. When mounting an output capacitor between the VOUT and VSS pins (C_L) and a capacitor for stabilizing the input between the VIN and VSS pins (C_{IN}), the distance from the capacitors to these pins should be as short as possible.
- Note that the output voltage may increase when a series regulator is used at low load current (1.0 mA or less).
- Generally a series regulator may cause oscillation depending on the selection of external parts. The following conditions are recommended for this IC. However, be sure to perform sufficient evaluation under the actual usage conditions for selection, including evaluation of temperature characteristics.

Input capacitor (C_{IN}):	1.0 μ F or more
Output capacitor (C_L):	1.0 μ F or more
Equivalent series resistance (ESR):	10 Ω or less

- The voltage regulator may oscillate when the impedance of the power supply is high and the input capacitor is small or an input capacitor is not connected.
- The application conditions for the input voltage, output voltage, and load current should not exceed the package power dissipation.
- Do not apply an electrostatic discharge to this IC that exceeds the performance ratings of the built-in electrostatic protection circuit.
- In determining the output current, attention should be paid to the output current value specified in **Table 7** of “**■ Electrical Characteristics**” and footnote *8 of the table.
- SII claims no responsibility for any disputes arising out of or in connection with any infringement by products including this IC of patents owned by a third party.

■ Characteristics (Typical Data)

1. Entire circuit

Current consumption during operation*1 vs. Input voltage (Ta = +25°C)

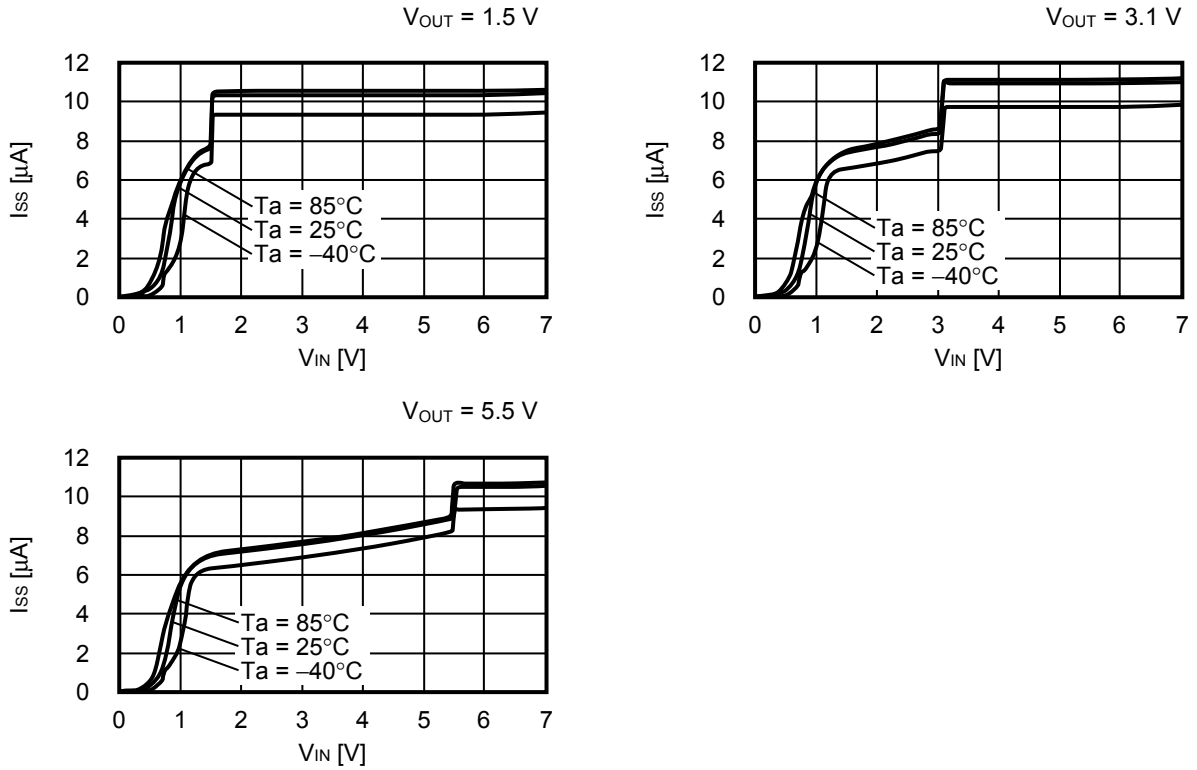

*1. Excluding current flowing in pull-up and pull-down resistors connected to the ON / OFF or RESX pins

2. Regulator block

2.1 Output voltage vs. Output current (when load current increases) (Ta = +25°C)

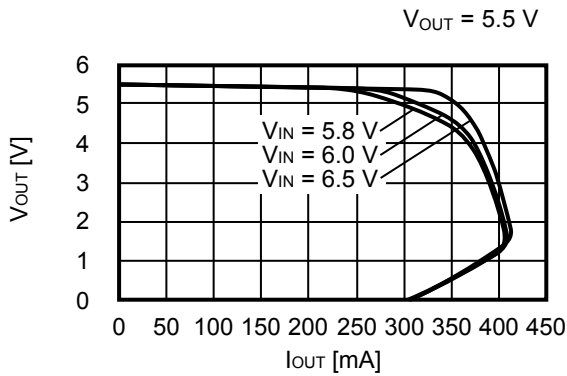
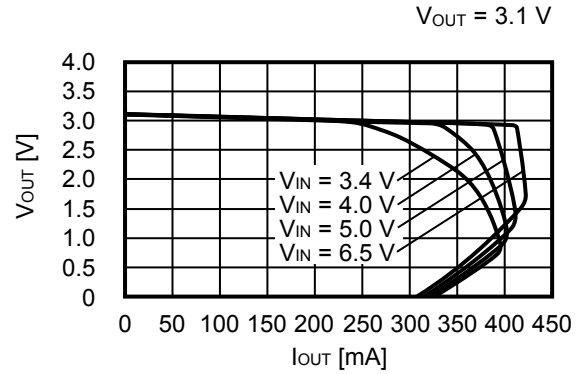
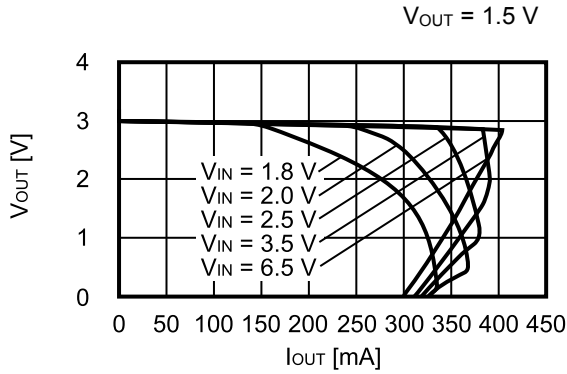

Remark In determining the output current, attention should be paid to the followings.
 (1) The minimum output current value and footnote *8 in Table 7 of "■ Electrical Characteristics".
 (2) Power dissipation of package

2.2 Output voltage vs. Input voltage (Ta = +25°C)

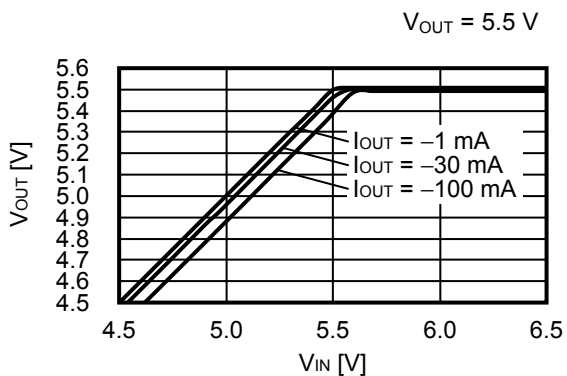
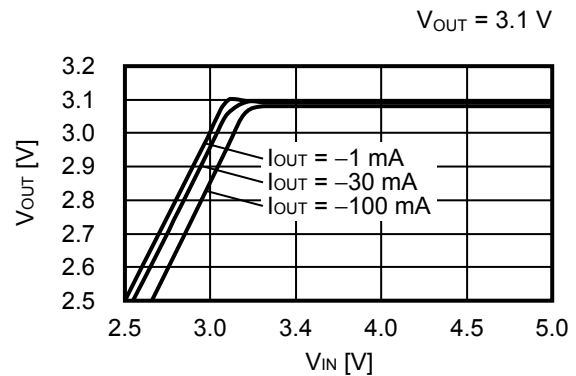
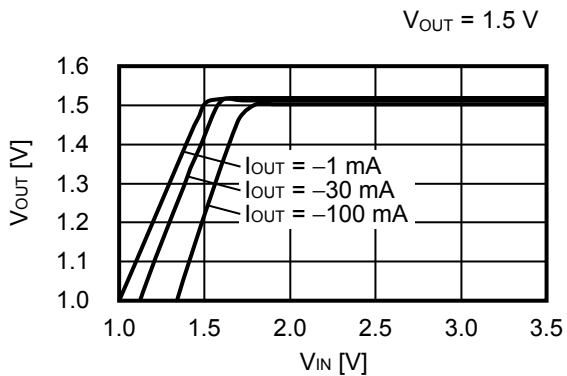

2.3 Dropout voltage vs. Output current

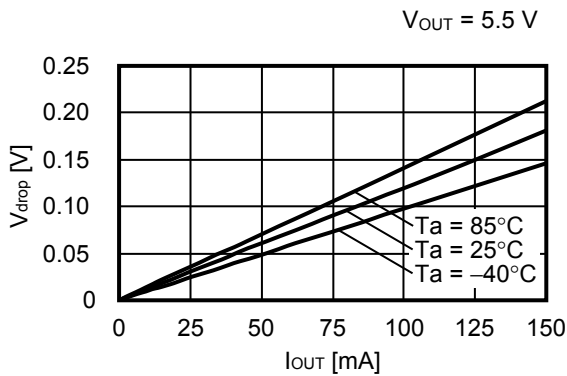
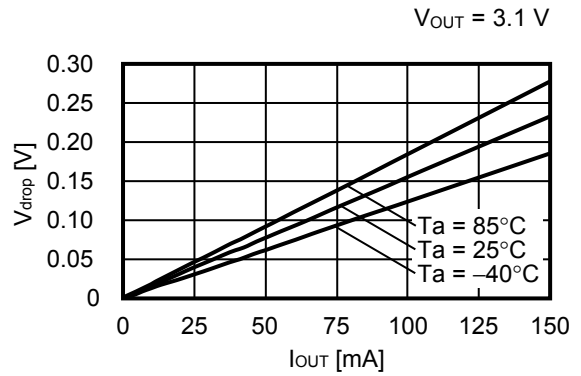
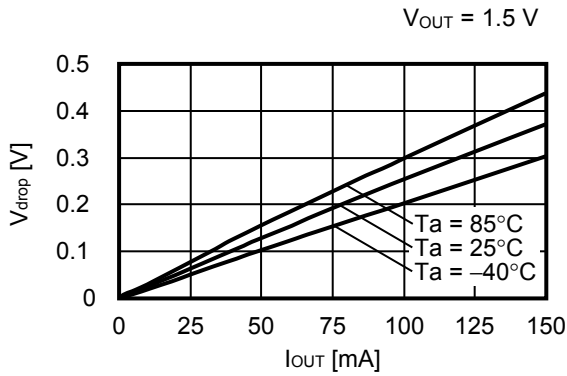

2.4 Output voltage vs. Ambient temperature

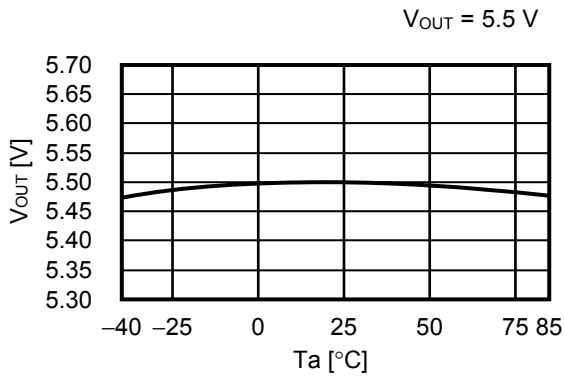
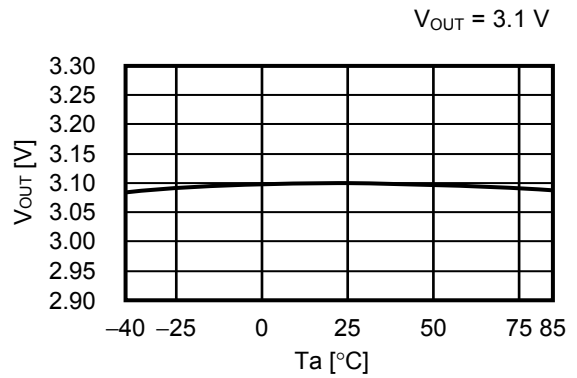
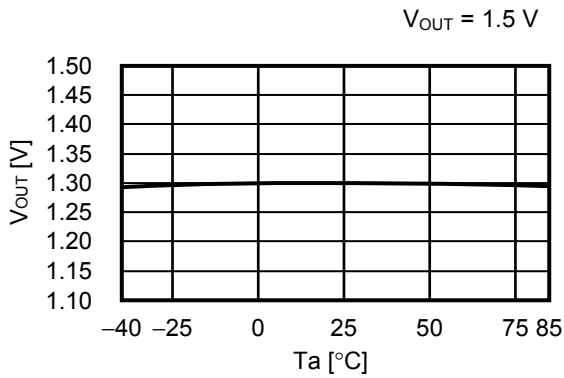

2.5 Current consumption during operation at regulator block*1 vs. Input voltage

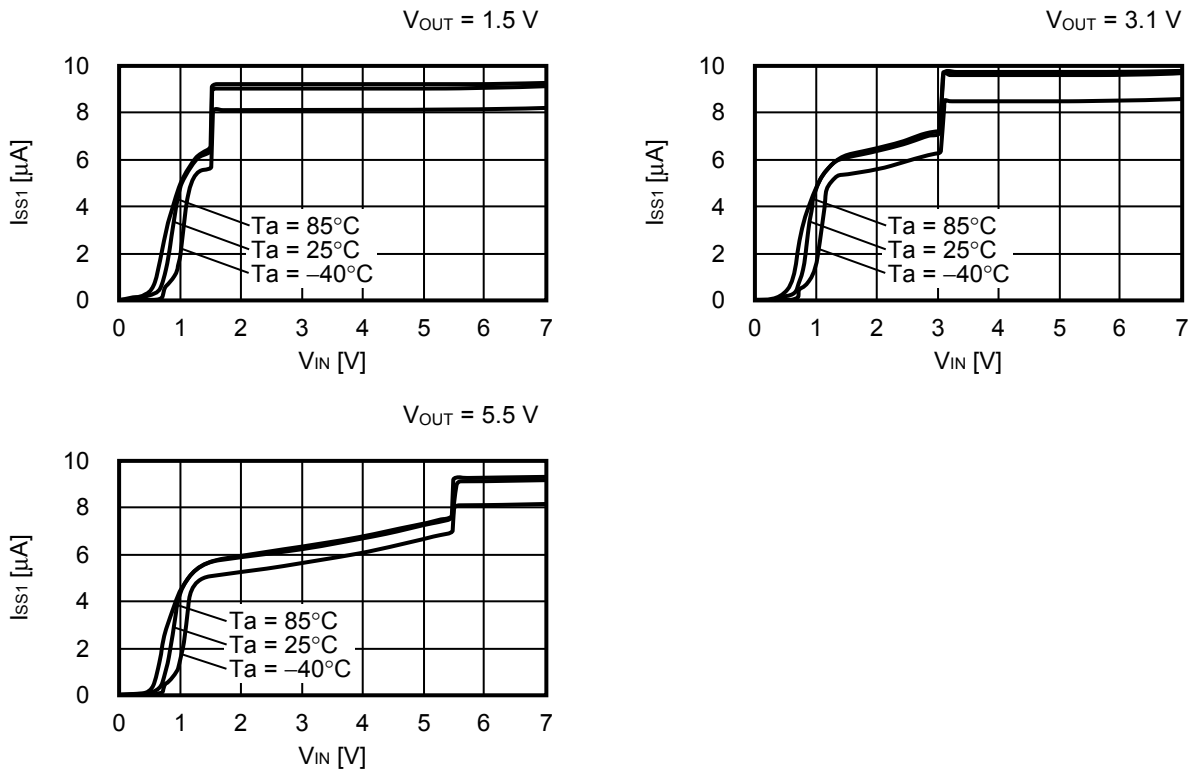

*1. Excluding current flowing in pull-up and pull-down resistors connected to the ON / OFF or RESX pins

2.6 Ripple rejection ratio ($T_a = +25^\circ\text{C}$)

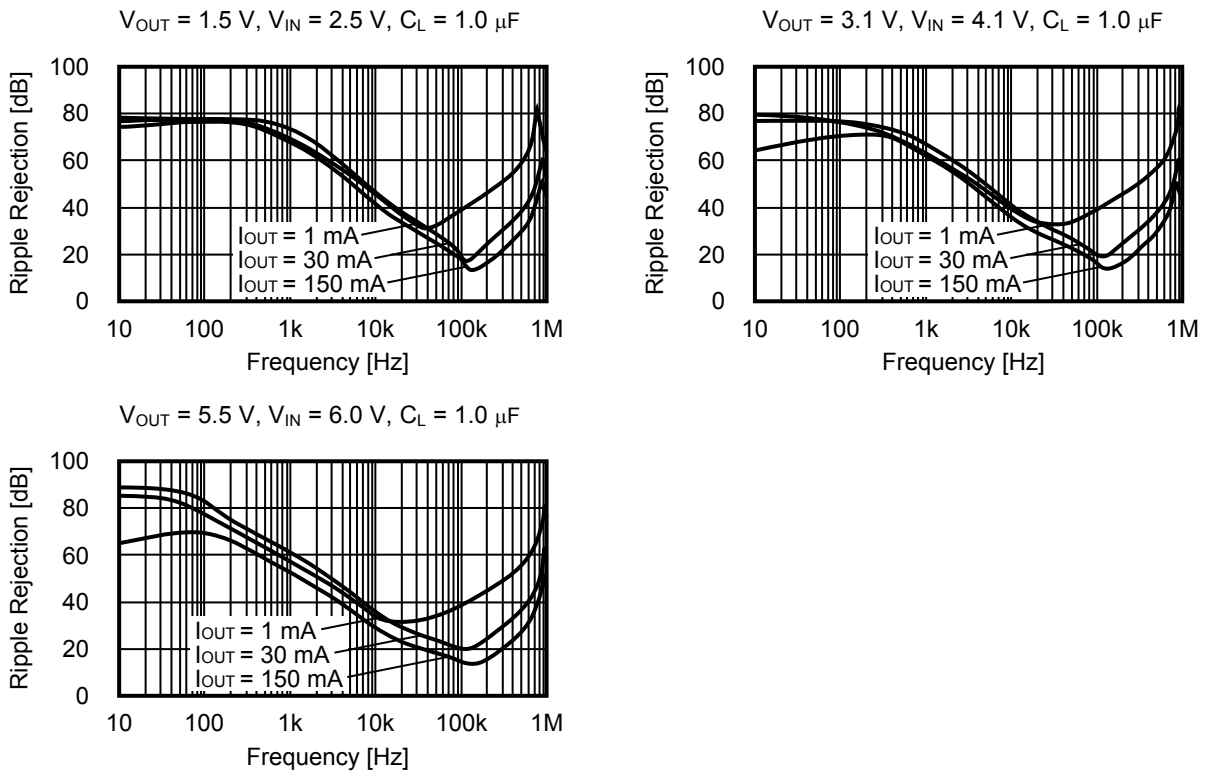

3. Detector block

3.1 Detection voltage vs. Ambient temperature

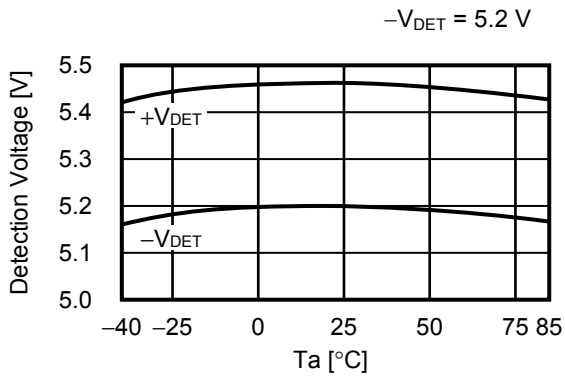
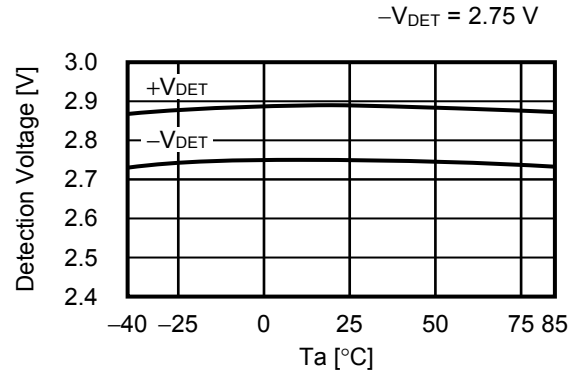
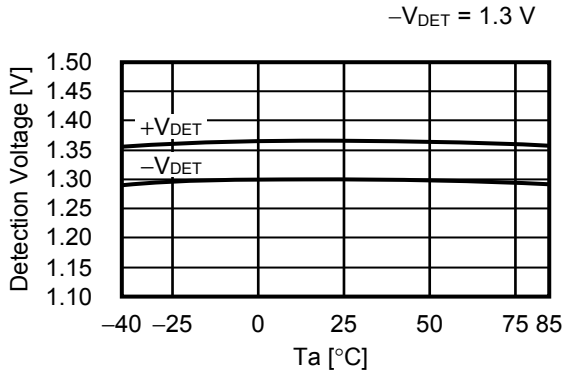

3.2 Hysteresis width vs. Ambient temperature

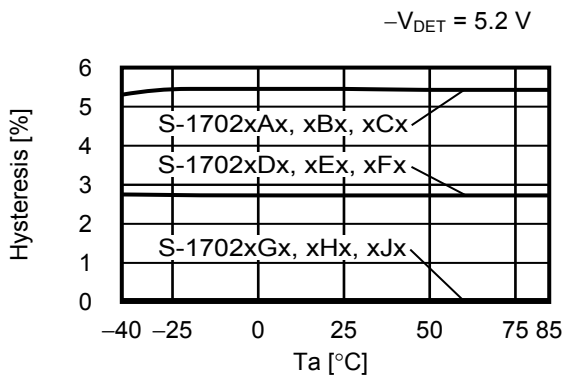
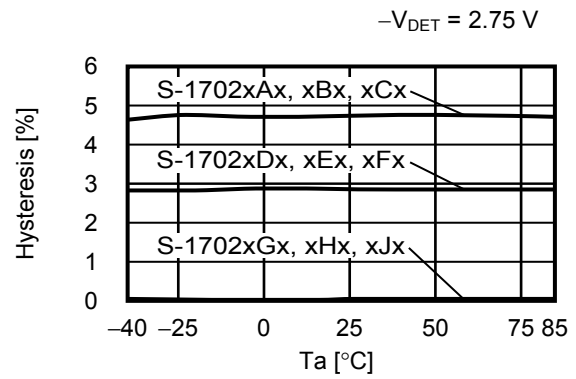
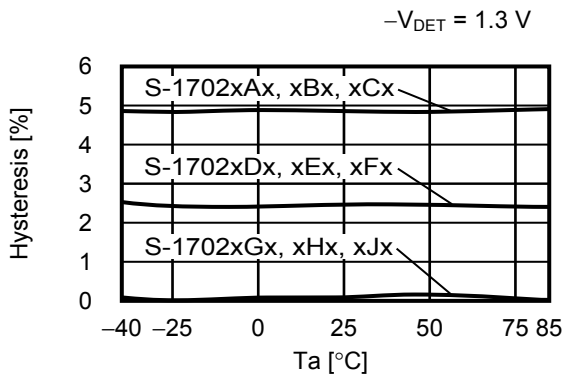

3.3 Current consumption during operation at detector block^{*1} vs. Input voltage

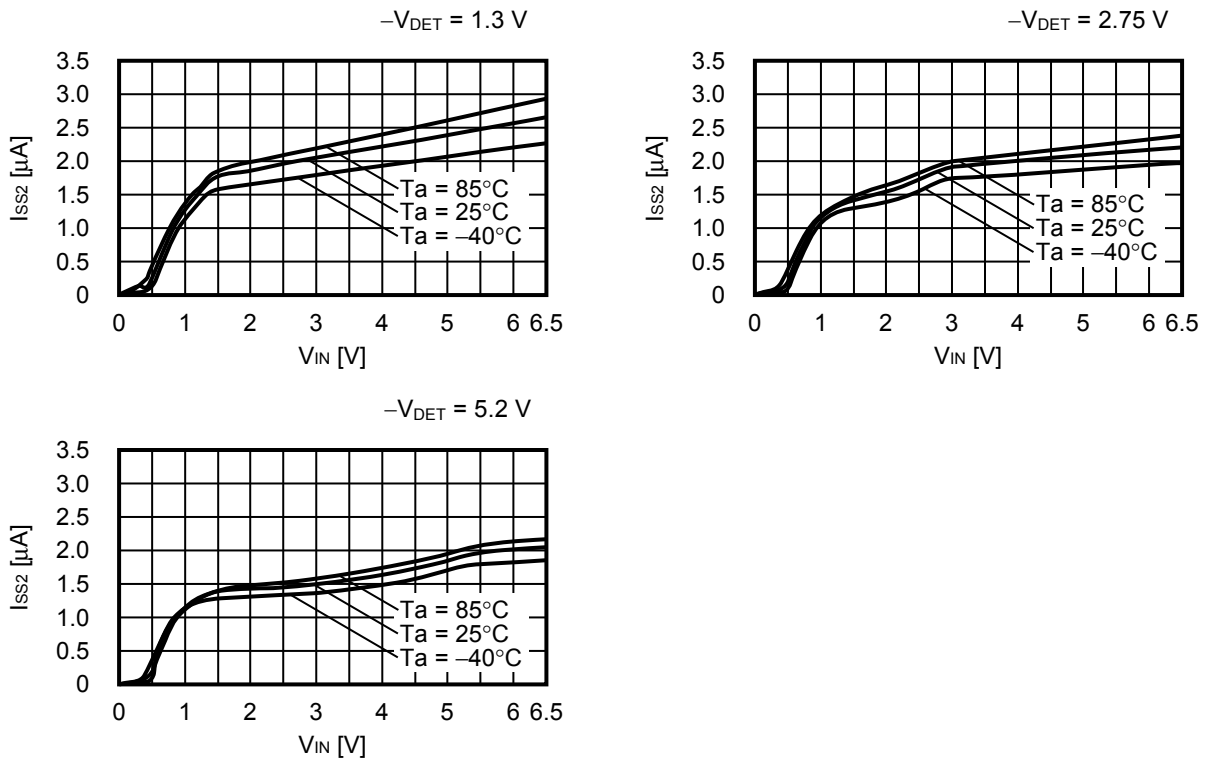

*1. Excluding current flowing in pull-up and pull-down resistors connected to the ON / OFF or RESX pins

3.4 Detector output voltage vs. Nch transistor characteristics (I_D vs. V_{DS} characteristics)

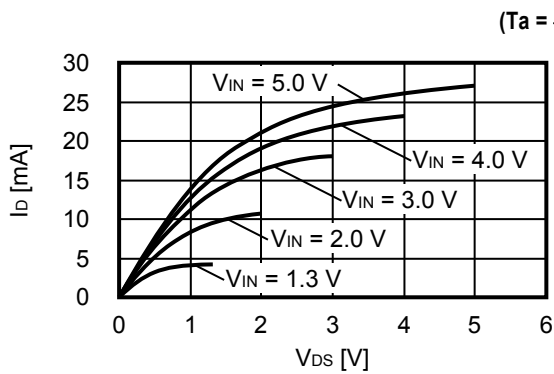

3.5 Detector output voltage vs. Pch transistor characteristics (I_D vs. V_{DS} characteristics)

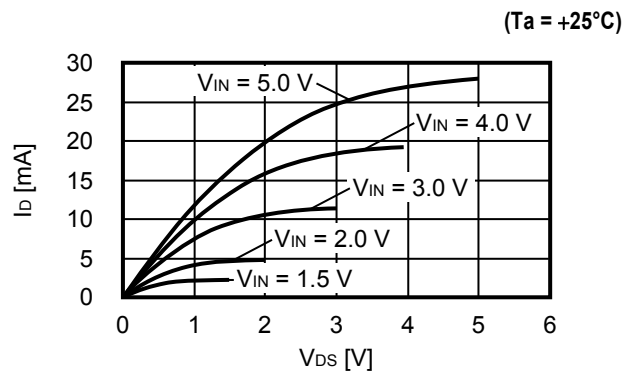

3.6 Detector output voltage vs. Input voltage

CMOS output

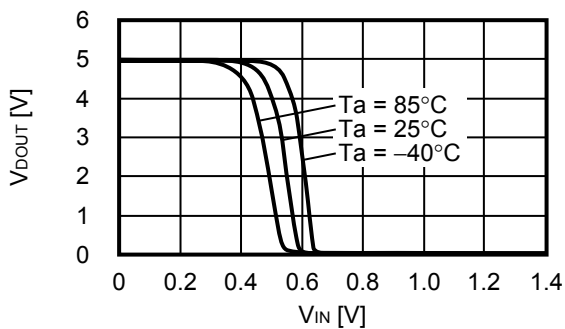

Nch open drain output

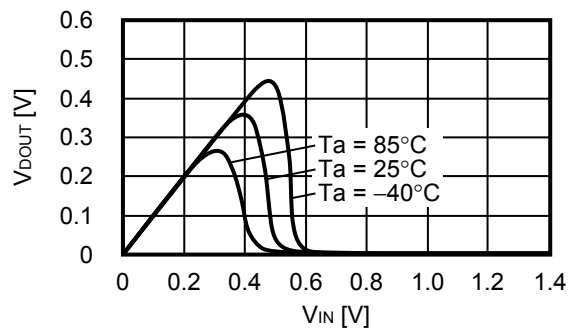

■ Reference Data

1. Input transient response characteristics (Ta = +25°C)

$I_{OUT} = 30 \text{ mA}$, $t_r = t_f = 5.0 \mu\text{s}$, $C_L = 1.0 \mu\text{F}$, $C_{IN} = 1.0 \mu\text{F}$
 $V_{OUT} = 1.5 \text{ V}$, $V_{IN} = 2.5 \text{ V} \leftrightarrow 3.5 \text{ V}$

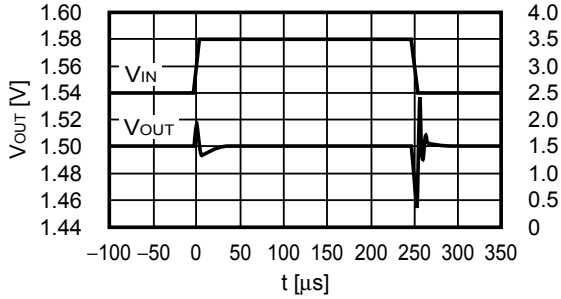

$I_{OUT} = 30 \text{ mA}$, $t_r = t_f = 5.0 \mu\text{s}$, $C_L = 1.0 \mu\text{F}$, $C_{IN} = 1.0 \mu\text{F}$
 $V_{OUT} = 3.1 \text{ V}$, $V_{IN} = 4.1 \text{ V} \leftrightarrow 5.1 \text{ V}$

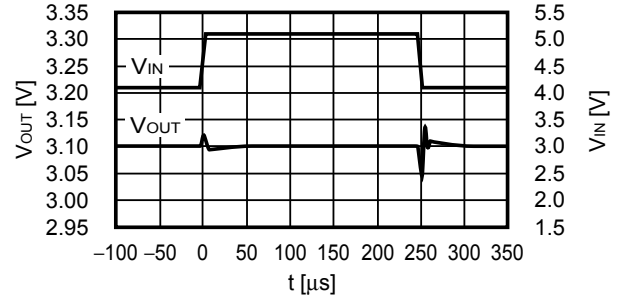

2. Load transient response characteristics (Ta = +25°C)

$V_{IN} = 2.5 \text{ V}$, $C_L = 1.0 \mu\text{F}$, $C_{IN} = 1.0 \mu\text{F}$
 $V_{OUT} = 1.5 \text{ V}$, $I_{OUT} = 50 \text{ mA} \leftrightarrow 100 \text{ mA}$

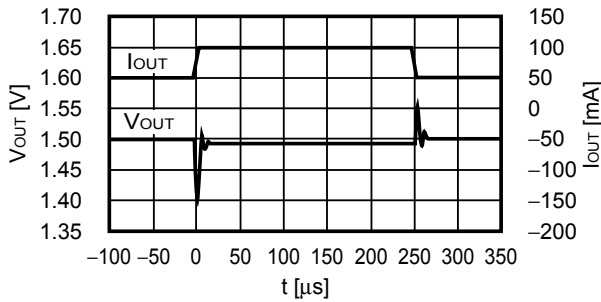

$V_{IN} = 4.0 \text{ V}$, $C_L = 1.0 \mu\text{F}$, $C_{IN} = 1.0 \mu\text{F}$
 $V_{OUT} = 3.1 \text{ V}$, $I_{OUT} = 50 \text{ mA} \leftrightarrow 100 \text{ mA}$

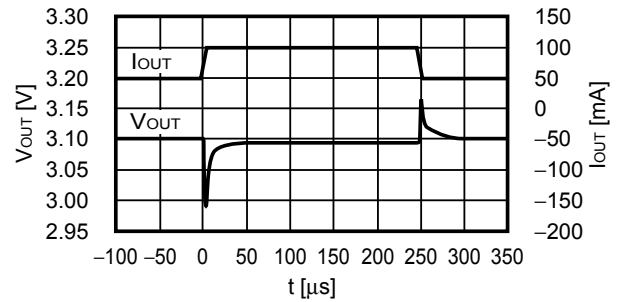

$V_{IN} = 6.0 \text{ V}$, $C_L = 1.0 \mu\text{F}$, $C_{IN} = 1.0 \mu\text{F}$
 $V_{OUT} = 5.5 \text{ V}$, $I_{OUT} = 50 \text{ mA} \leftrightarrow 100 \text{ mA}$

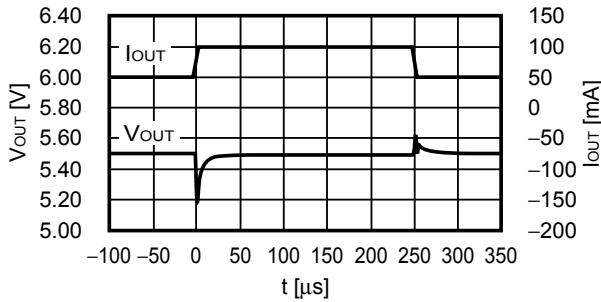

3. ON/OFF pin transient response characteristics (Ta = +25°C)

$V_{IN} = 2.5\text{ V}$, $C_L = 1.0\ \mu\text{F}$, $C_{IN} = 1.0\ \mu\text{F}$, $I_{OUT} = 100\text{ mA}$
 $V_{OUT} = 1.5\text{ V}$, $V_{ON/OFF} = 0\text{ V} \rightarrow 2.5\text{ V}$

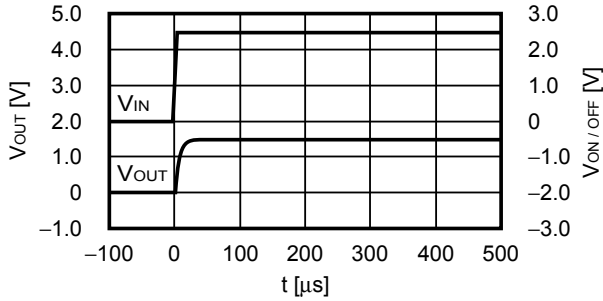

$V_{IN} = 4.0\text{ V}$, $C_L = 1.0\ \mu\text{F}$, $C_{IN} = 1.0\ \mu\text{F}$, $I_{OUT} = 100\text{ mA}$
 $V_{OUT} = 3.1\text{ V}$, $V_{ON/OFF} = 0\text{ V} \rightarrow 4.0\text{ V}$

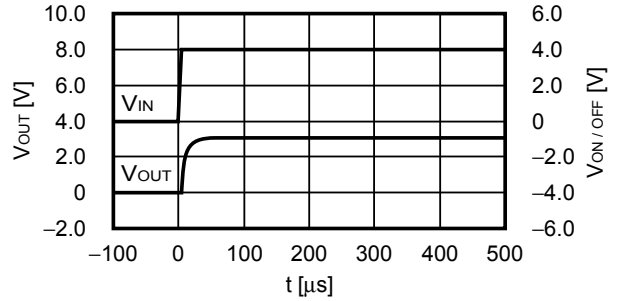

$V_{IN} = 6.0\text{ V}$, $C_L = 1.0\ \mu\text{F}$, $C_{IN} = 1.0\ \mu\text{F}$, $I_{OUT} = 100\text{ mA}$
 $V_{OUT} = 5.5\text{ V}$, $V_{ON/OFF} = 0\text{ V} \rightarrow 6.5\text{ V}$

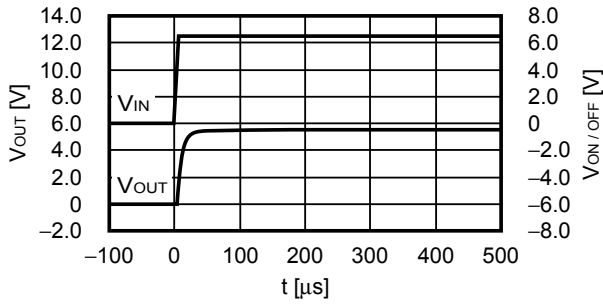

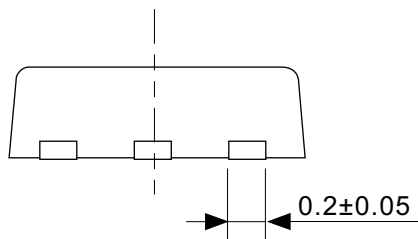
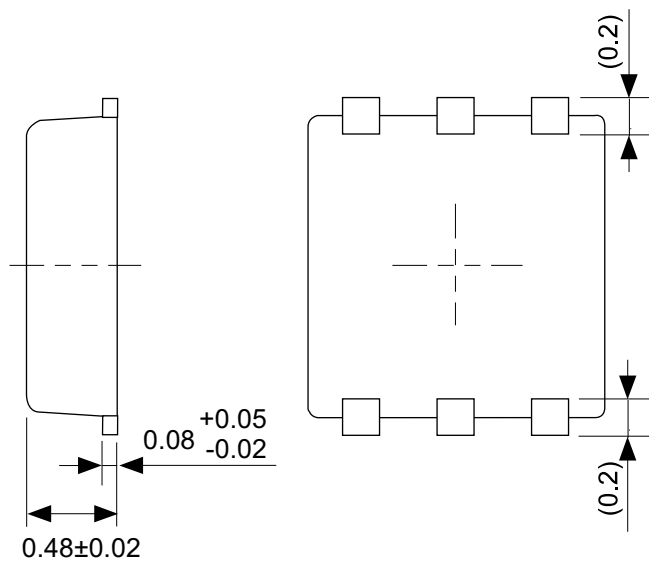
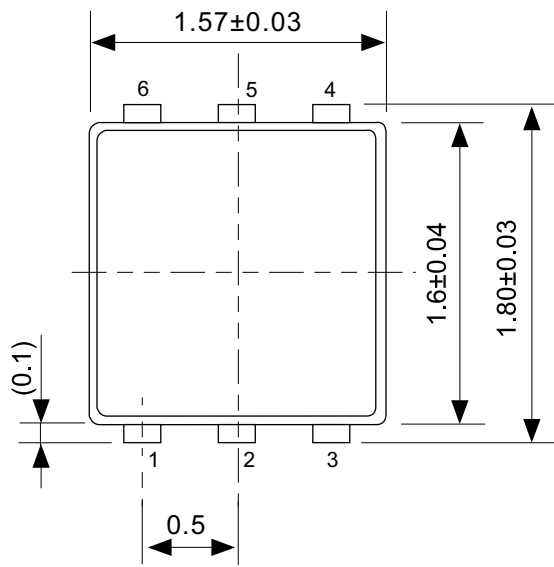

No. PG006-A-P-SD-2.0

TITLE	SNT-6A-A-PKG Dimensions
No.	PG006-A-P-SD-2.0
SCALE	
UNIT	mm
Seiko Instruments Inc.	

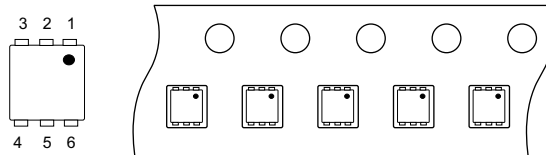
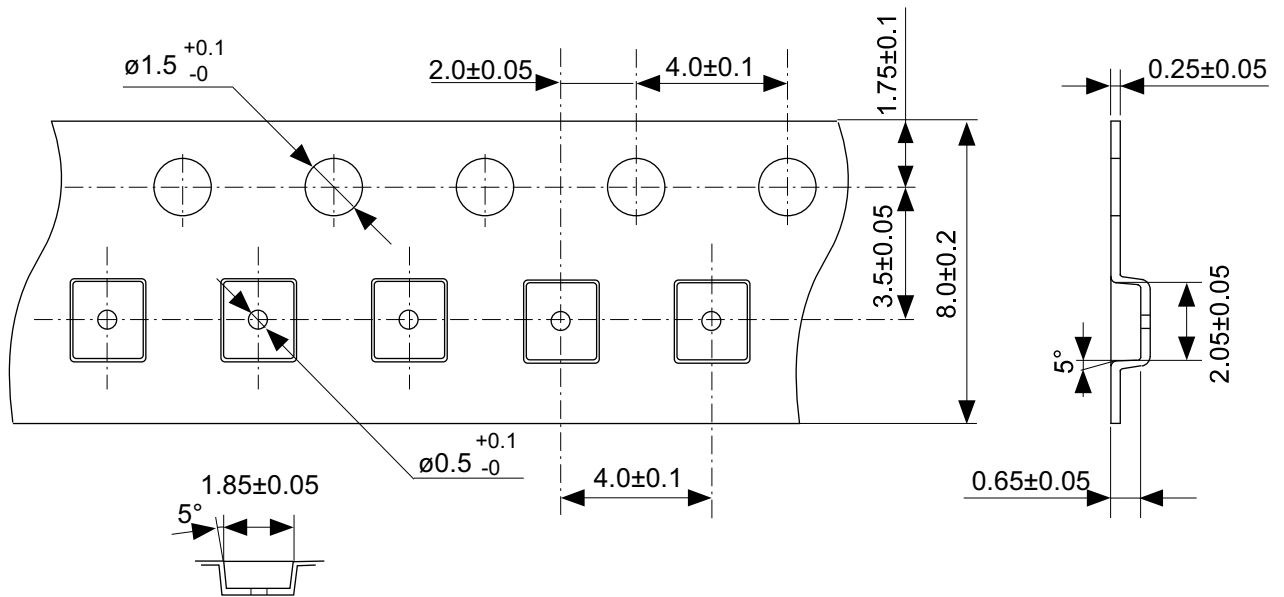

→
Feed direction

No. PG006-A-C-SD-1.0

TITLE	SNT-6A-A-Carrier Tape
No.	PG006-A-C-SD-1.0
SCALE	
UNIT	mm
Seiko Instruments Inc.	

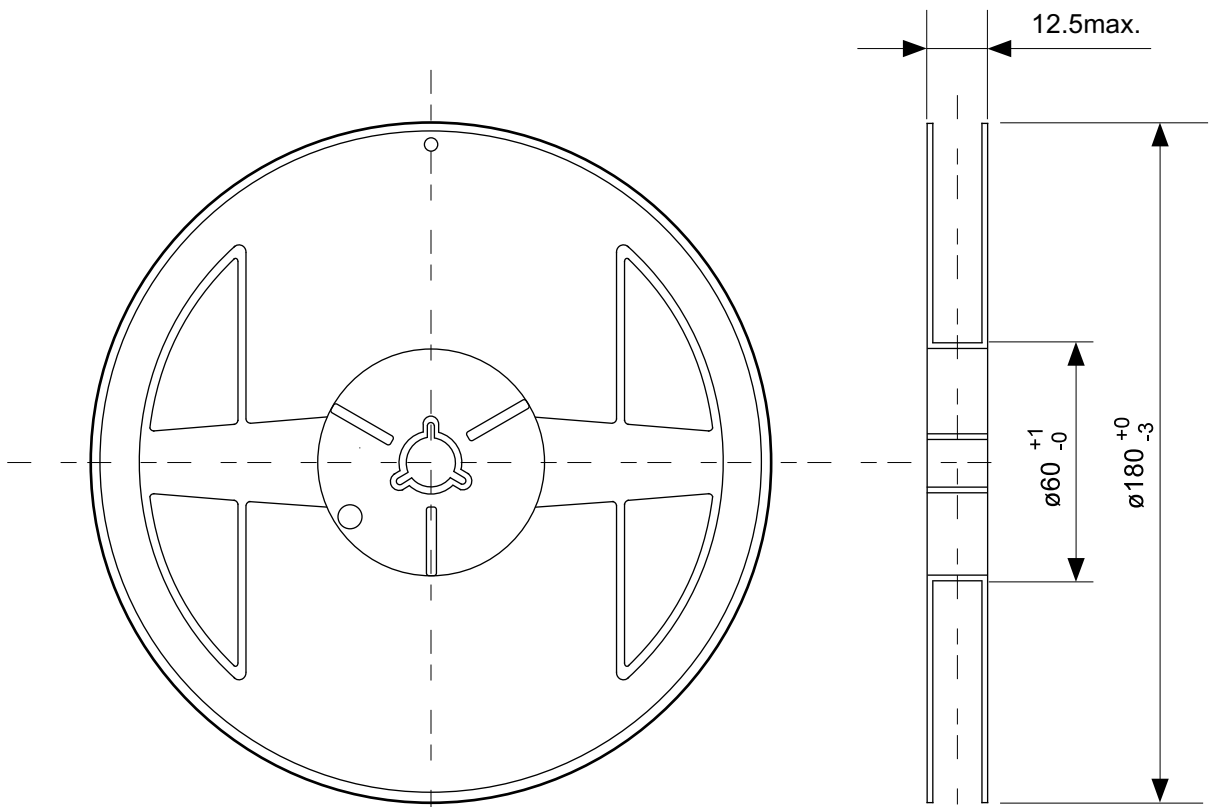

Enlarged drawing in the central part

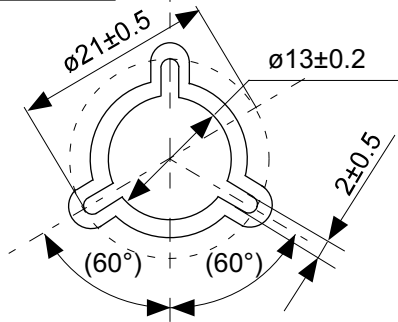

No. PG006-A-R-SD-1.0

TITLE	SNT-6A-A-Reel		
No.	PG006-A-R-SD-1.0		
SCALE		QTY.	5,000
UNIT	mm		
Seiko Instruments Inc.			

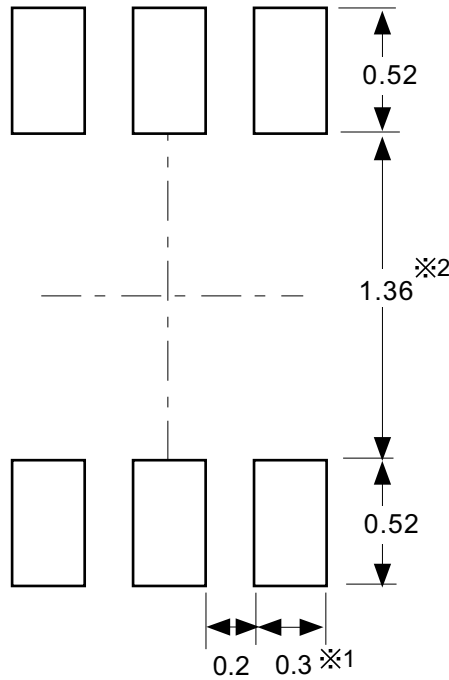

※1. ランドパターンの幅に注意してください (0.25 mm min. / 0.30 mm typ.).
 ※2. パッケージ中央にランドパターンを広げないでください (1.30 mm ~ 1.40 mm)。

- 注意
1. パッケージのモールド樹脂下にシルク印刷やハンダ印刷などしないでください。
 2. パッケージ下の配線上のソルダーレジストなどの厚みをランドパターン表面から0.03 mm以下にしてください。
 3. マスク開口サイズと開口位置はランドパターンと合わせてください。
 4. 詳細は“SNTパッケージ活用の手引き”を参照してください。

※1. Pay attention to the land pattern width (0.25 mm min. / 0.30 mm typ.).
 ※2. Do not widen the land pattern to the center of the package (1.30 mm ~ 1.40 mm).

- Caution**
1. Do not do silkscreen printing and solder printing under the mold resin of the package.
 2. The thickness of the solder resist on the wire pattern under the package should be 0.03 mm or less from the land pattern surface.
 3. Match the mask aperture size and aperture position with the land pattern.
 4. Refer to "SNT Package User's Guide" for details.

※1. 请注意焊盘模式的宽度 (0.25 mm min. / 0.30 mm typ.).
 ※2. 请勿向封装中间扩展焊盘模式 (1.30 mm ~ 1.40 mm)。

- 注意
1. 请勿在树脂型封装的下面印刷丝网、焊锡。
 2. 在封装下、布线上的阻焊膜厚度 (从焊盘模式表面起) 请控制在0.03 mm以下。
 3. 掩膜的开口尺寸和开口位置请与焊盘模式对齐。
 4. 详细内容请参阅 "SNT封装的应用指南"。

No. PG006-A-L-SD-4.0

TITLE	SNT-6A-A-Land Recommendation
No.	PG006-A-L-SD-4.0
SCALE	
UNIT	mm
Seiko Instruments Inc.	



Seiko Instruments Inc.
www.sii-ic.com

- The information described herein is subject to change without notice.
- Seiko Instruments Inc. is not responsible for any problems caused by circuits or diagrams described herein whose related industrial properties, patents, or other rights belong to third parties. The application circuit examples explain typical applications of the products, and do not guarantee the success of any specific mass-production design.
- When the products described herein are regulated products subject to the Wassenaar Arrangement or other agreements, they may not be exported without authorization from the appropriate governmental authority.
- Use of the information described herein for other purposes and/or reproduction or copying without the express permission of Seiko Instruments Inc. is strictly prohibited.
- The products described herein cannot be used as part of any device or equipment affecting the human body, such as exercise equipment, medical equipment, security systems, gas equipment, vehicle equipment, in-vehicle equipment, aviation equipment, aerospace equipment, and nuclear-related equipment, without prior written permission of Seiko Instruments Inc.
- The products described herein are not designed to be radiation-proof.
- Although Seiko Instruments Inc. exerts the greatest possible effort to ensure high quality and reliability, the failure or malfunction of semiconductor products may occur. The user of these products should therefore give thorough consideration to safety design, including redundancy, fire-prevention measures, and malfunction prevention, to prevent any accidents, fires, or community damage that may ensue.