



SINGLE PHASE BRIDGE RECTIFIER

**KBPC6005 THRU KBPC610
BR605 THRU BR610**

VOLTAGE RANGE **50 to 1000 Volts**
CURRENT **6.0 Ampere**

FEATURES

- Low cost
- This series in UL recognized under component index, file number E127707
- High forward surge current capacity
- Ideal for printed circuit board
- High isolation voltage from case to leads
- High temperature soldering guaranteed: 260°C / 10 seconds, at 5 lbs. (2.3kg) tension.

MECHANICAL DATA

- Technology: Cell with vacuum soldered
- Case: Molded plastic body
- Terminal: Lead solderable per MIL-STD-202E method 208C
- Polarity: Polarity symbols marked on case
- Mounting: Thru hole for #10 screw, 5 in-lbs torque max.
- Weight: 0.13 ounce, 3.66 gram

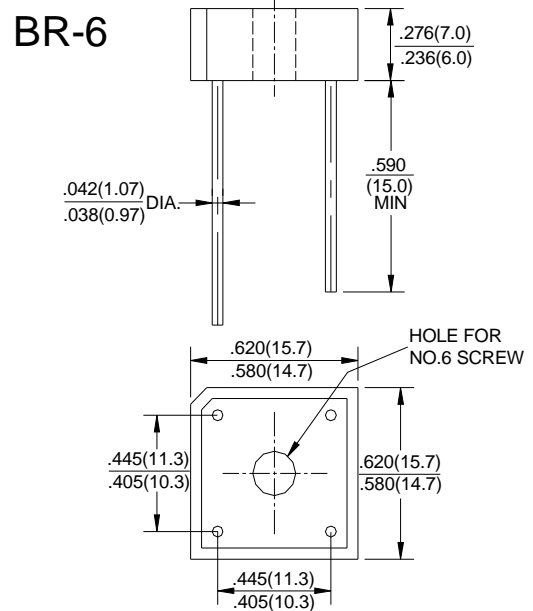

MAXIMUM RATINGS AND ELECTRICAL CHARACTERISTICS

- Ratings at 25°C ambient temperature unless otherwise specified
- Single Phase, half wave, 60Hz, resistive or inductive load
- For capacitive load derate current by 20%

	SYMBOLS	KBPC6005 BR605	KBPC601 BR61	KBPC602 BR62	KBPC604 BR64	KBPC606 BR66	KBPC608 BR68	KBPC610 BR610	UNIT
Maximum Repetitive Peak Reverse Voltage	V_{RRM}	50	100	200	400	600	800	1000	Volts
Maximum RMS Voltage	V_{RMS}	35	70	140	280	420	560	700	Volts
Maximum DC Blocking Voltage	V_{DC}	50	100	200	400	600	800	1000	Volts
Maximum Average Forward Rectified Output Current, at	$T_C = 50^\circ\text{C}$ (Note 1)	6.0							Amps
	$T_A = 25^\circ\text{C}$ (Note 2)	3.0							
Peak Forward Surge Current 8.3mS single half sine wave superimposed on rated load (JEDEC method)	I_{FSM}	125							Amps
Rating for Fusing ($t < 8.3\text{mS}$)	I^2t	64							A^2s
Maximum Instantaneous Forward Voltage drop per Bridge element at 3.0 A	V_F	1.0							Volts
Maximum DC Reverse Current at Rated DC Blocking Voltage per element	$T_A = 25^\circ\text{C}$	5.0							μA
	$T_A = 100^\circ\text{C}$	1.0							mA
Isolation Voltage from case to lug	V_{ISO}	2500							Volts
Typical Thermal Resistance (Note 1)	$R_{\theta Jc}$	8.0							$^\circ\text{C}/\text{W}$
Operating Temperature Rang	T_J	-55 to +150							$^\circ\text{C}$
Storage Temperature Rang	T_{STG}	-55 to +150							$^\circ\text{C}$

Notes:

1. Unit mounted on 6.0" x 5.5" x 0.11" thick (15×14×0.3cm) AL plate
2. Unit mounted on P.C. Board 0.375" (9.5mm) lead length with 0.47"×0.47" (12×12mm) copper pads.



SINGLE PHASE BRIDGE RECTIFIER

**KBPC6005 THRU KBPC610
BR605 THRU BR610**

VOLTAGE RANGE	50 to 1000 Volts
CURRENT	6.0 Ampere

RATINGS AND CHARACTERISTIC CURVES KBPC6005 THRU KBPC610

FIG.1- DERATING CURVE FOR
OUTPUT RECTIFIED CURRENT

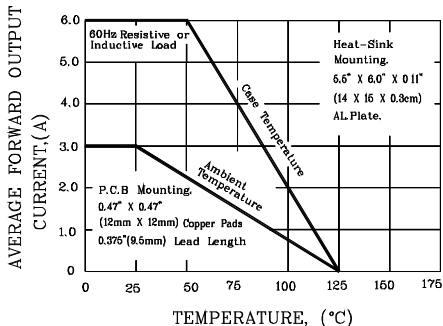

FIG.2- MAXIMUM NON-REPETITIVE PEAK FORWARD SURGE CURRENT PER ELEMENT

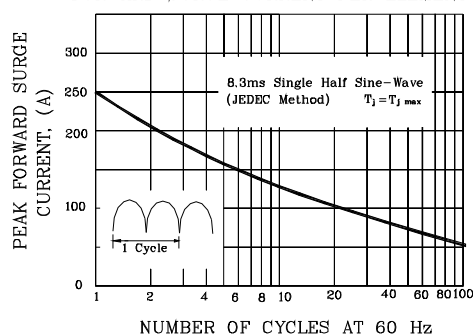

FIG.3- TYPICAL FORWARD CHARACTERISTICS PER BRIDGE ELEMENT

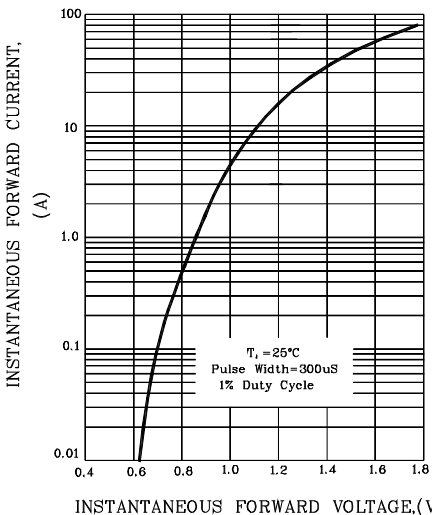

FIG.4- TYPICAL REVERSE CHARACTERISTICS PER BRIDGE ELEMENT

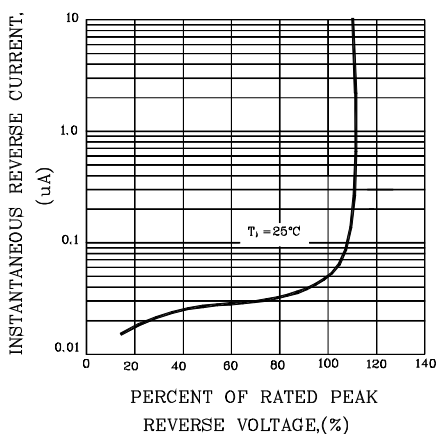

FIG.5- TYPICAL JUNCTION CAPACITANCE PER BRIDGE ELEMENT

