

**Silicon NPN Power Transistors**

**2SC5299**

**DESCRIPTION**

- With TO-3PML package
- High breakdown voltage, high reliability.
- High speed

**APPLICATIONS**

- Ultrahigh-definition CRT display
- Horizontal deflection output applications

**PINNING**

PIN	DESCRIPTION
1	Base
2	Collector
3	Emitter

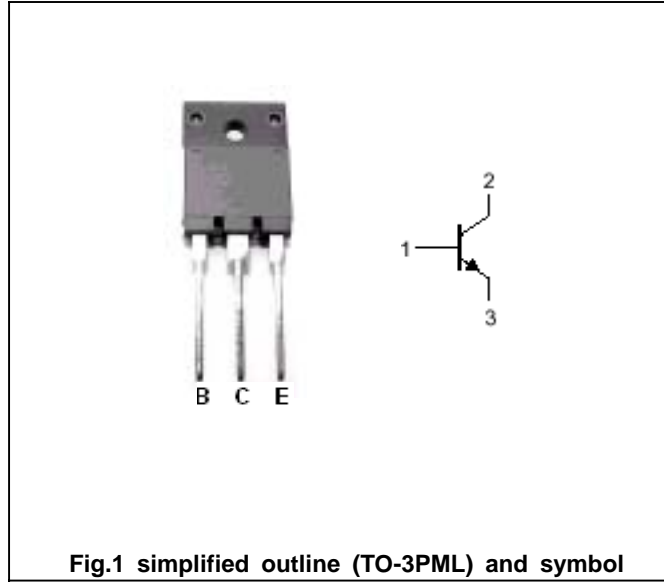

Fig.1 simplified outline (TO-3PML) and symbol

**Maximum absolute ratings(Ta=25 )**

SYMBOL	PARAMETER	CONDITIONS	VALUE	UNIT
V <sub>CBO</sub>	Collector-base voltage	Open emitter	1500	V
V <sub>CEO</sub>	Collector-emitter voltage	Open base	800	V
V <sub>EBO</sub>	Emitter-base voltage	Open collector	6	V
I <sub>C</sub>	Collector current		10	A
I <sub>CM</sub>	Collector current-peak		25	A
P <sub>C</sub>	Collector power dissipation	T <sub>C</sub> =25	70	W
			3	W
T <sub>j</sub>	Junction temperature		150	
T <sub>stg</sub>	Storage temperature		-55~150	

## Silicon NPN Power Transistors

## 2SC5299

## CHARACTERISTICS

T<sub>j</sub>=25 unless otherwise specified

SYMBOL	PARAMETER	CONDITIONS	MIN	TYP.	MAX	UNIT
V <sub>CEsat</sub>	Collector-emitter saturation voltage	I <sub>C</sub> =8A; I <sub>B</sub> =2 A			5	V
V <sub>BEsat</sub>	Base-emitter saturation voltage	I <sub>C</sub> =8A; I <sub>B</sub> =2 A			1.5	V
V <sub>CEO(SUS)</sub>	Collector-emitter sustaining voltage	I <sub>C</sub> =100mA; I <sub>B</sub> =0	800			V
I <sub>EBO</sub>	Emitter cut-off current	V <sub>EB</sub> =4V ; I <sub>C</sub> =0			1.0	mA
I <sub>CB0</sub>	Collector cut-off current	V <sub>CB</sub> =800V I <sub>E</sub> =0			10	μ A
I <sub>CES</sub>	Collector cut-off current	V <sub>CE</sub> =1500V; R <sub>BE</sub> =0			1	mA
h <sub>FE-1</sub>	DC current gain	I <sub>C</sub> =1 A ; V <sub>CE</sub> =5V	20		30	
h <sub>FE-2</sub>	DC current gain	I <sub>C</sub> =8A ; V <sub>CE</sub> =5V	4		7	

## Switching times

t <sub>stg</sub>	Storage time	I <sub>C</sub> =6A; R <sub>L</sub> =33.3 I <sub>B1</sub> =1.2A; I <sub>B2</sub> =-2.4A V <sub>CC</sub> =200V			3.0	μ s
t <sub>f</sub>	Fall time			0.1	0.2	μ s

Silicon NPN Power Transistors

2SC5299

PACKAGE OUTLINE

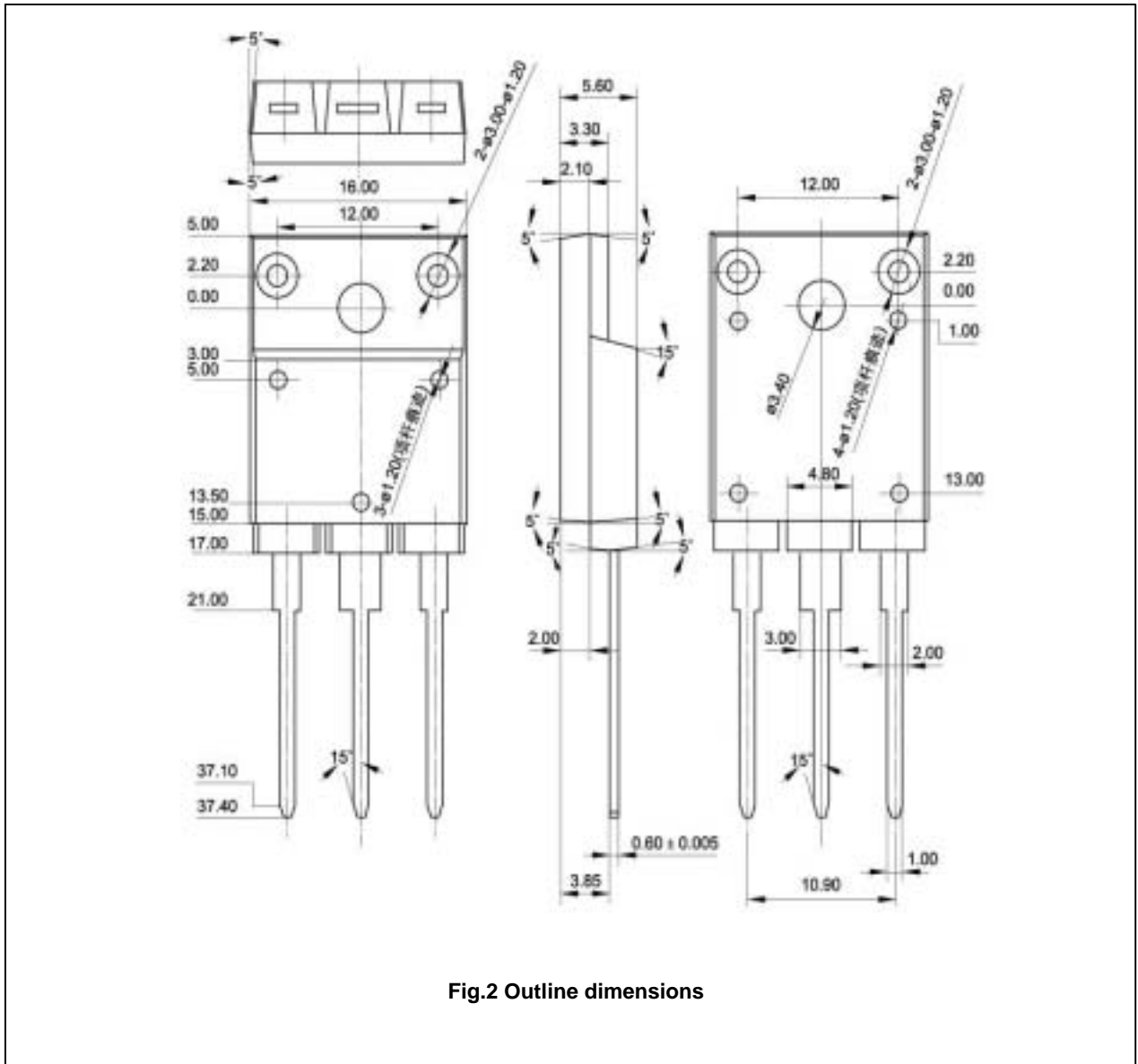

Fig.2 Outline dimensions