

5.5V Standard Capacitor Series DB

GREEN
CAP

70°C

- Small-sized, large capacity, excellent voltage holding.
- For all ratings, uniform 5mm pitch of terminal spacing.
- Wider temperature range (-25 to +70°C) than battery.
- $\phi 21.5 \times 7.5$ size can encase up to 1.5F.
- Ideal for backing up of CMOS's, IC's, microcomputers, RAM's, RTC's and the like used in Video's, tuners, TV sets, telephone sets and others.



Marking color : White print on an indigo sleeve

■ SPECIFICATIONS

Item	Performance									
Category Temperature Range	-25°C~+70°C									
Tolerance at rated capacitance	-20%~+80%									
Internal resistance at 1 kHz	Rated capacitance (F)	0.047	0.1	0.22	0.33	0.47	0.47	1.0	1.5	
	Internal resistance (Ω)	120	75	75	75	75 ($\phi 13.5$)	30 ($\phi 21.5$)	30	30	
Characteristics at high and low temperature	Percentage of capacitance change					Within $\pm 30\%$ of the value at 20°C				
	Internal resistance					Less than five times of the value at 20°C				
Endurance (70°C)	Test time					1000 hours				
	Percentage of capacitance change					Within $\pm 30\%$ of the initial measured value				
	Internal resistance					Within four times of the initial specified value				
Shelf life (70°C)	Test time : 1000 hours; Same as endurance.									
Applicable standards	Conforms to JIS C5160-1 2009 (IEC 62391-1 2006)									

■ OUTLINE DRAWING

Unit : mm

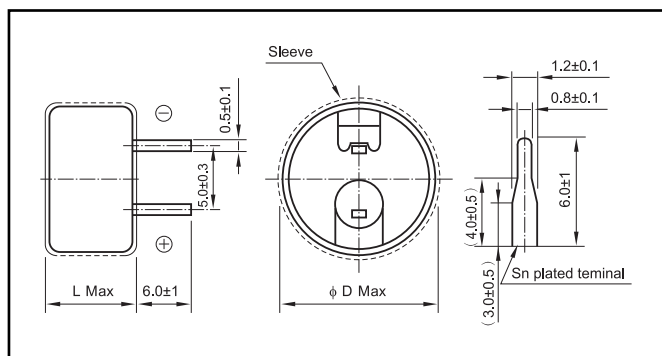

■ STANDARD RATINGS

Max. operating voltage (V)	Rated capacitance (F)	ELNA Parts No.	$\phi D \times L$ (mm)
5.5	0.047	DB-5R5D473T	13.5×7.5
5.5	0.1	DB-5R5D104T	13.5×7.5
5.5	0.22	DB-5R5D224T	13.5×7.5
5.5	0.33	DB-5R5D334T	13.5×7.5
5.5	0.47	DB-5R5D474ST	13.5×7.5
5.5	0.47	DB-5R5D474T	21.5×8.0
5.5	1.0	DB-5R5D105T	21.5×8.0
5.5	1.5	DB-5R5D155T	21.5×8.0

Part numbering system (example : 5.5V0.1F)

DB	—	5R5	D	104		T
Series code		Rated voltage symbol	Terminal code	Rated capacitance symbol	Additional symbol	

Part number is refer to above table.

NOTE

Design, Specifications are subject to change without notice.
Ask factory for technical specifications before purchase and/or use.