

APPROVED: _____
 DATE: _____ TITLE: _____

Rev	AWO #	Description	Date	Appr
-		RELEASED	10/27/10	
A		ADDED DIM.	10/4/13	AY

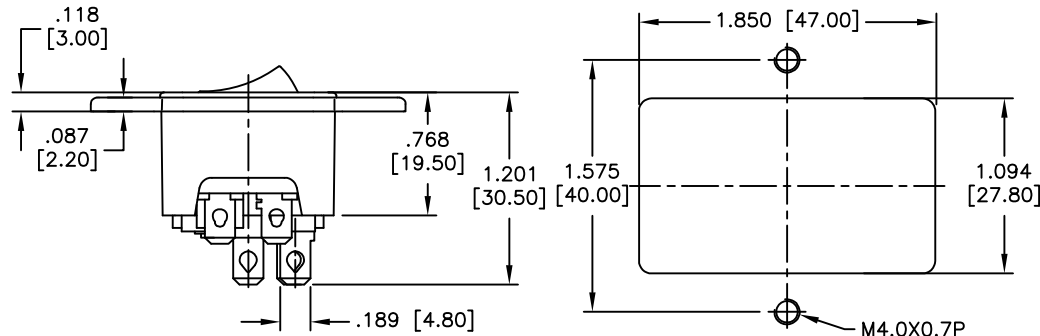
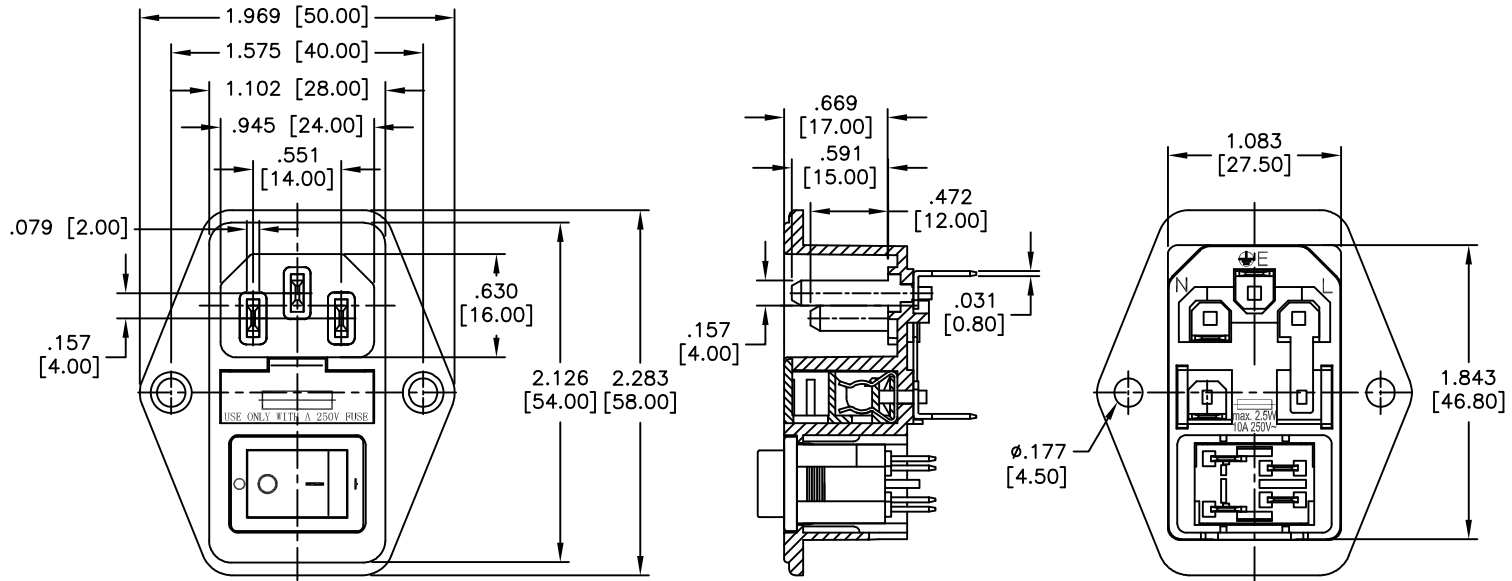

RECOMMENDED PANEL CUT-OUT

SPECIFICATIONS:

Material:
 Insulator: Thermoplastic, glass reinforced, rated UL 94V-0
 Insulator color: Black
 Contacts: Brass
 Plating:
 Tin over Copper underplate overall
 Electrical:
 Operating voltage: 250 VAC
 Current rating: UL & CSA: 15 Amps max
 VDE: 10 Amps max
 Insulation resistance: 100 Mohms min @ 500 VDC
 Dielectric withstanding voltage: 2,000 VAC for 1 minute
 Temperature Rating:
 Operating temperature: -25°C to +70°C
 Environmental:
 Lead free, RoHS compliant



UNLESS OTHERWISE SPECIFIED ALL DIMENSIONS ARE INCHES [MM] TOLERANCES: EXCEPT AS NOTED		
INCHES		HOLES
.X	± .10	∅X ± .10
.XX	± .020	∅XX ± .015
.XXX	± .015	∅XXX ± .010

APPROVALS		DATE
DRAWN	AY	10/27/10
CHECKED	AH	10/27/10
APPROVED		

ADAM TECH

909 Rahway Avenue, Union, NJ 07083
 Phone: 908-687-5000 Fax: 908-687-5710

TITLE: IEC MALE, FUSED INLET WITH SWITCH
 SCREW ON PANEL MOUNT

SIZE	PART NO.	REV.
X	IEC-FS-1	A

REF: S00080T SCALE: NTS SHEET 1 OF 1