

Ceramic SMD Crystal Unit SMD 8.0 x 4.5mm Type

MX8 series

MERITEK

FEATURE

- Surface Mount Low Profile
- Glass Sealed Ceramic
- Excellent Heat Resistance
- High precision and high frequency stability
- Applications: Wired Network, Mobile Communication, WiMAX, WLAN, Test Equipment



PART NUMBERING SYSTEM

MX8 F H J C 20M0
(1) (2) (3) (4) (5) (6)



No	Item	Code	Description	Series Reference
(1)	Meritek Series	MX8	Crystal Unit	Ceramic SMD Crystal 8.0x4.5mm 2 Pads
(2)	Load Capacitance	F	F: 20pF	E: 18pF, R: Series Resonance (see options)
(3)	Frequency Tolerance	H	H: ± 30 ppm	F: ± 20 ppm, G: ± 25 ppm (see options)
(4)	Stability vs Oper Temp.	J	J: ± 50 ppm	G: ± 25 ppm, H: ± 30 ppm (see options)
(5)	Operating Temp.	C	C: $-20 \sim +70^\circ\text{C}$	C: $-20 \sim +70^\circ\text{C}$, I: $-40 \sim +85^\circ\text{C}$ (see options)
(6)	Frequency	20M0	20M0: 20.000MHz	6M0 ~ 80M0 (M denotes decimal point)

DIMENSIONS AND RECOMMENDED PATTERN

PIN	PIN Layout
1	Input / Output
2	Output / Input

(Unit:mm)

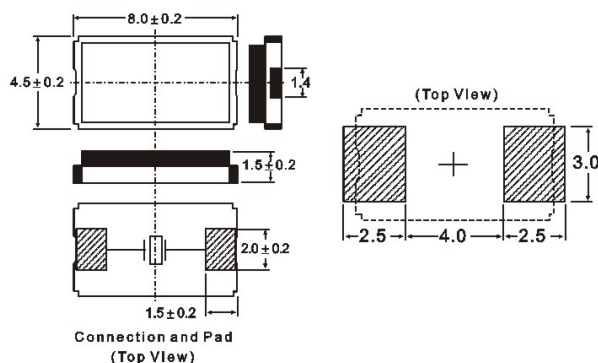

AVAILABLE OPTIONS

Parameters	Part Number Options
Load Capacitance	R: Series Resonance, 3: 3pF ~ 8: 8pF, A: 10pF, B: 12pF, C: 15pF, D: 16pF, E: 18pF, F: 20pF, K: 22pF, G: 25pF, H: 30pF, L: 32pF
Frequency Tolerance	A: ± 10 ppm, C: ± 15 ppm, F: ± 20 ppm, G: ± 25 ppm, H: ± 30 ppm, J: ± 50 ppm
Stability vs Oper Temp.	A: ± 10 ppm, C: ± 15 ppm, F: ± 20 ppm, G: ± 25 ppm, H: ± 30 ppm, J: ± 50 ppm, K: ± 100 ppm
Operating Temperature	B: $0 \sim +70^\circ\text{C}$, A: $-10 \sim +60^\circ\text{C}$, C: $-20 \sim +70^\circ\text{C}$, K: $-30 \sim +85^\circ\text{C}$, I: $-40 \sim +85^\circ\text{C}$, R: $-40 \sim +105^\circ\text{C}$

Note: Custom options available. Contact Meritek for more information.

Ceramic SMD Crystal Unit

SMD 8.0 x 4.5mm Type

MX8 series

MERITEK

ELECTRICAL CHARACTERISTICS

Parameters		Characteristic
Frequency Range		6.000 ~ 80.000 MHz
Operation Mode	Fundamental	6.000 ~ 30.000 MHz
	3 rd Overtone	30.001 ~ 80.000 MHz
Load Capacitance		18 pF (see options)
Frequency Tolerance (at 25°C)		±30 ppm (see options)
Freq Stability over Oper Temp.		±50 ppm (see options)
Operating Temperature		-55 ~ +125°C (see options)
Storage Temperature		-40 ~ +85°C
Drive Level		100µW max. (10 typ.)
Aging		±5 ppm / year
Shunt Capacitance		5.0 pF max.
Insulation Resistance		500 MΩ min. (@100Vdc ±15V)
Equivalent Series Resistance	6.0 ~ 9.999 Fundamental	70 Ω max.
	10.0 ~ 30.000 Fundamental	40 Ω max.
	30.001 ~ 44.999 (3 rd OT)	60 Ω max.
	45.0 ~ 80.000 (3 rd OT)	50 Ω max.

RECOMMENDED SOLDERING PROFILES

Reflow Condition		
Pre Heat	Temp. Min $T_{s(min)}$	150°C
	Temp. Max $T_{s(max)}$	180°C
	Time (min. to max.) (t_s)	60~120 seconds
Average ramp up rate (T_L) to peak		1°C/second max.
$T_{s(max)}$ to T_L (Ramp-up rate)		3°C/second max.
Reflow	Temp. (T_L)	230°C
	Time (min. to max.) (t_L)	30~40 seconds
Peak Temperature (T_P)		260°C
Time within 5°C of actual peak Temperature (t_p)		10 seconds max.
Ramp-down Rate		6°C/second

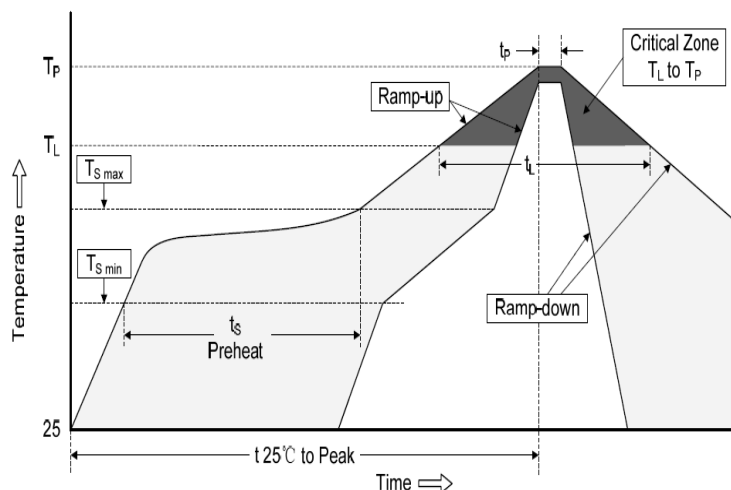

*Specifications subject to change without notice.