

# EF2005FCT THRU EF2060FCT

## List

List..... 1

Package outline..... 2

Features..... 2

Mechanical data..... 2

Maximum ratings .....2

Rating and characteristic curves..... 3

Pinning information.....4

Marking..... 4

Tube packing.....4

Suggested thermal profiles for soldering processes..... 5

High reliability test capabilities.....6

# EF2005FCT THRU EF2060FCT

## 20.0A Glass Passivated Efficient Fast Rectifiers-50-600V

### Features

- Reverse recovery time less than 25ns
- Dual rectifier construction, positive centetap, offers 10.0A half wave and 20.0A full wave rectification.
- High current capability.
- Low reverse leakage current.
- High surge capability.
- Glass passivated chip junction.
- Low forward drop down voltage.
- High reliability.
- Lead-free parts meet RoHS requirements.
- Suffix "-H" indicates Halogen free parts, ex. EF2005FCT-H.

### Mechanical data

- Epoxy : UL94-V0 rated flame retardant
- Case : ITO-220AB Molded plastic
- Terminals: Lead solderable per MIL-STD-750, Method 2026
- Polarity: As marked
- Mounting Position : Any
- Weight : Approximated 1.70grams

### Package outline

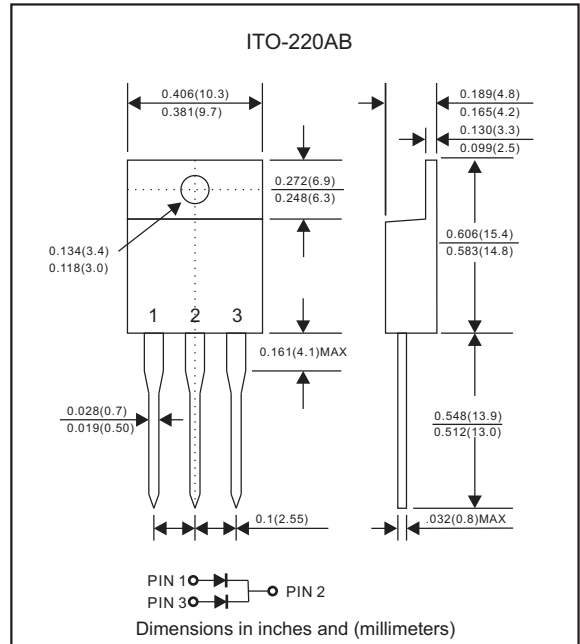

### Maximum ratings (AT $T_A=25^{\circ}\text{C}$ unless otherwise noted)

PARAMETER	SYMBOLS	EF2005FCT	EF2010FCT	EF2020FCT	EF2040FCT	EF2060FCT	UNIT	
Maximum repetitive peak reverse voltage	$V_{RRM}$	50	100	200	400	600	V	
Maximum RMS voltage	$V_{RMS}$	35	70	140	280	420	V	
Maximum DC blocking voltage	$V_{DC}$	50	100	200	400	600	V	
Maximum average forward rectified current	$I_o$	20.0						A
Peak forward surge current 8.3ms single half sine-wave(JEDEC method)	$I_{FSM}$	100						A
Typical diode junction capacitance (Note 1)	$C_J$	85						pF
Operating junction temperature range	$T_J$	-55 to +150						$^{\circ}\text{C}$
Storage temperature range	$T_{STG}$	-65 to +175						$^{\circ}\text{C}$

### Electrical characteristics (AT $T_A=25^{\circ}\text{C}$ unless otherwise noted)

PARAMETER	SYMBOLS	EF2005FCT	EF2010FCT	EF2020FCT	EF2040FCT	EF2060FCT	UNIT
Maximum forward voltage per leg at $I_F=10.0A$	$V_F$	0.98			1.30	1.75	V
Maximum DC reverse current at rated DC blocking voltage per leg at $T_J=25^{\circ}\text{C}$ at $T_J=125^{\circ}\text{C}$	$I_R$	5.0 500					$\mu\text{A}$ $\mu\text{A}$
Maximum reverse recovery time per leg (Note 2)	$t_{rr}$	25					ns

### Thermal characteristics

PARAMETER	SYMBOLS	EF2005FCT	EF2010FCT	EF2020FCT	EF2040FCT	EF2060FCT	UNIT
Typical thermal resistance junction to case per leg	$R_{\theta JC}$	2.0					$^{\circ}\text{C}/\text{W}$

Note 1: Measure at 1 MHz and applied reverse voltage of 4.0 V D.C.  
 Note 2: Reverse recovery time test condition,  $I_F=0.5A$ ,  $I_R=1.0A$ ,  $IRR=0.25A$

# Rating and characteristic curves (EF2005FCT THRU EF2060FCT)

FIG.1-TYPICAL FORWARD CURRENT DERATING CURVE

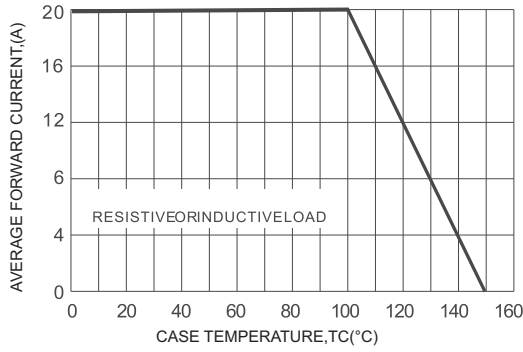

FIG.2-TYPICAL FORWARD CHARACTERISTICS

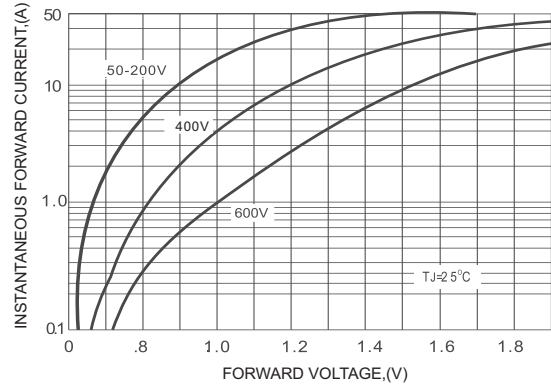

FIG.3- MAXIMUM NON-REPETITIVE FORWARD SURGE CURRENT

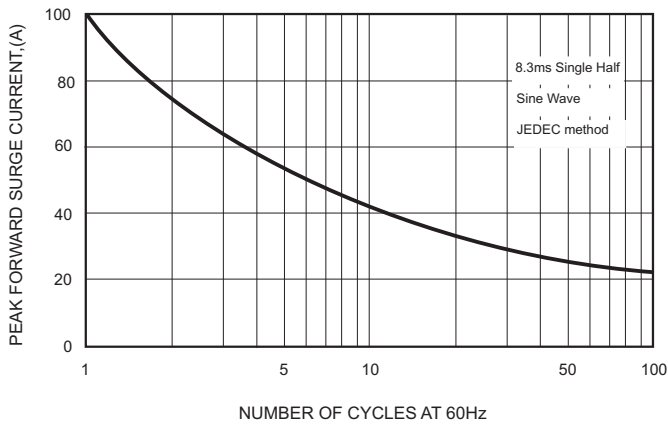

FIG.4 - TYPICAL REVERSE CHARACTERISTICS

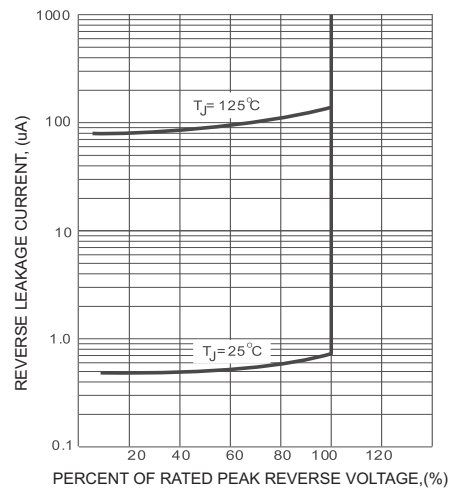
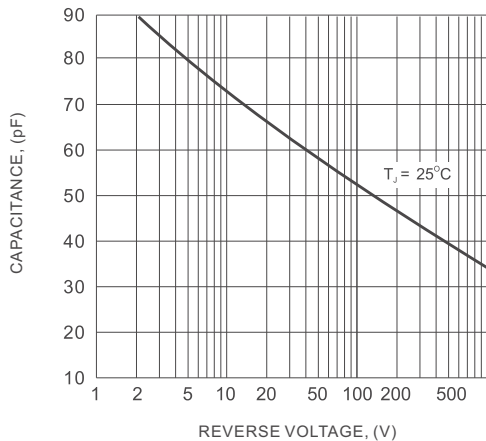
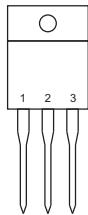
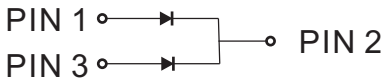

FIG.5- TYPICAL JUNCTION CAPACITANCE



# EF2005FCT THRU EF2060FCT

## Pinning information

Pin	Simplified outline	Symbol
Pin1 anode Pin2 cathode Pin3 anode		

## Marking

Type number	Marking code
EF2005FCT	EF2005FCT
EF2010FCT	EF2010FCT
EF2020FCT	EF2020FCT
EF2040FCT	EF2040FCT
EF2060FCT	EF2060FCT

## Tube packing

PACKAGE	TUBE (pcs)	TUBE SIZE (m/m)	BOX (pcs)	INNER BOX (m/m)	CARTON SIZE (m/m)	CARTON (pcs)	APPROX. GROSS WEIGHT (kg)
ITO-220AB	50	525*32*7.0	1000	555*150*40	580*230*175	5,000	15.0

# EF2005FCT THRU EF2060FCT

## Suggested thermal profiles for soldering processes

### 1. Lead free temperature profile wave-soldering

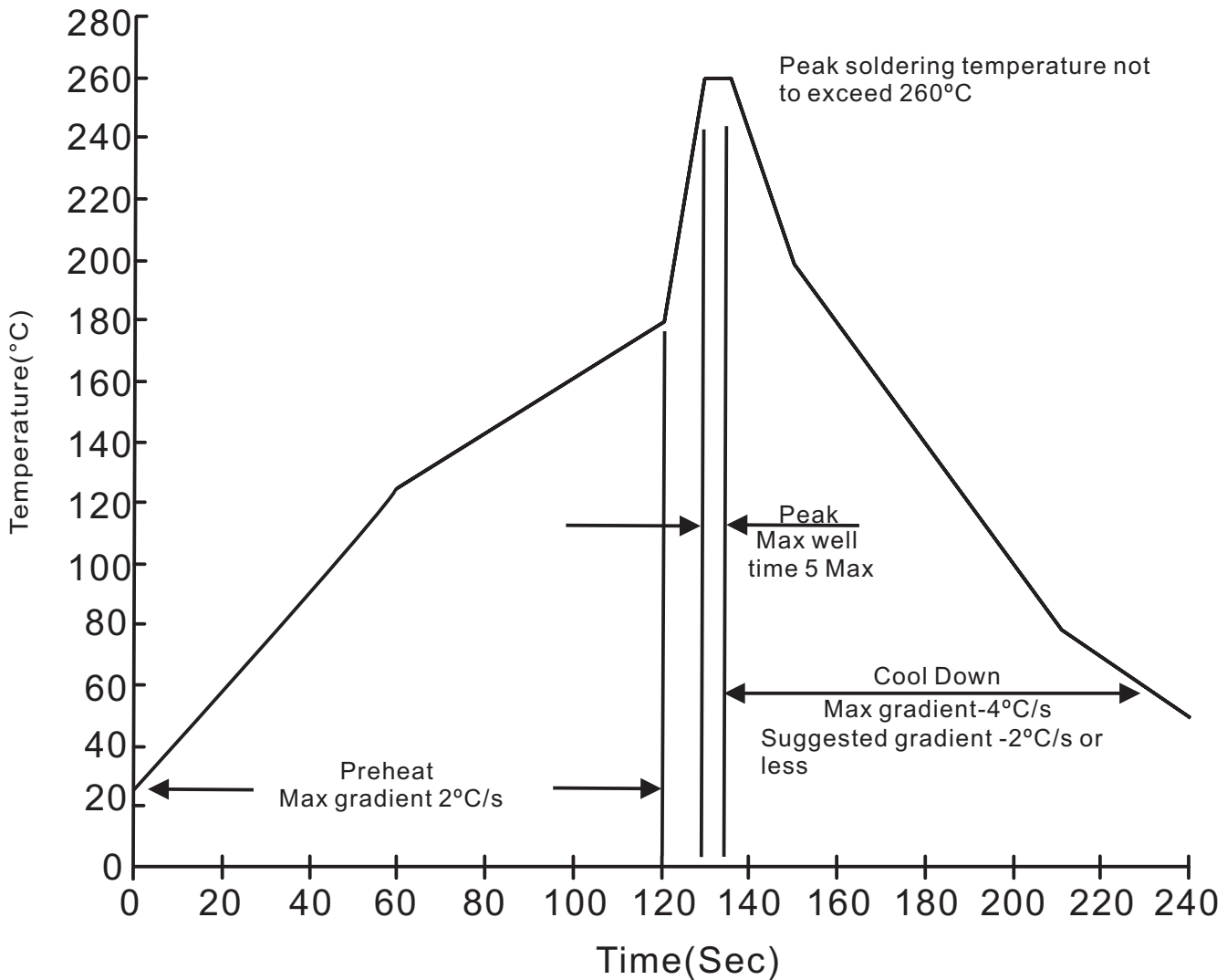

# EF2005FCT THRU EF2060FCT

## High reliability test capabilities

Item Test	Conditions	Reference
1. Solder Resistance	at $260\pm 5^{\circ}\text{C}$ for $10\pm 2\text{sec}$ . immerse body into solder $1/16''\pm 1/32''$	MIL-STD-750D METHOD-2031
2. Solderability	at $245\pm 5^{\circ}\text{C}$ for 5 sec.	MIL-STD-202F METHOD-208
3. High Temperature Reverse Bias	$V_R=80\%$ rate at $T_J=150^{\circ}\text{C}$ for 168 hrs.	MIL-STD-750D METHOD-1038
4. Forward Operation Life	Rated average rectifier current at $T_A=25^{\circ}\text{C}$ for 500hrs.	MIL-STD-750D METHOD-1027
5. Intermittent Operation Life	$T_A = 25^{\circ}\text{C}$ , $I_F = I_O$ On state: power on for 5 min. off state: power off for 5 min. on and off for 500 cycles.	MIL-STD-750D METHOD-1036
6. Pressure Cooker	$15P_{SIG}$ at $T_A=121^{\circ}\text{C}$ for 4 hrs.	JESD22-A102
7. Temperature Cycling	$-55^{\circ}\text{C}$ to $+125^{\circ}\text{C}$ dwelled for 30 min. and transferred for 5min. total 10 cycles.	MIL-STD-750D METHOD-1051
8. Forward Surge	8.3ms single half sine-wave , one surge.	MIL-STD-750D METHOD-4066-2
9. Humidity	at $T_A=85^{\circ}\text{C}$ , RH=85% for 1000hrs.	MIL-STD-750D METHOD-1021
10. High Temperature Storage Life	at $175^{\circ}\text{C}$ for 1000 hrs.	MIL-STD-750D METHOD-1031