

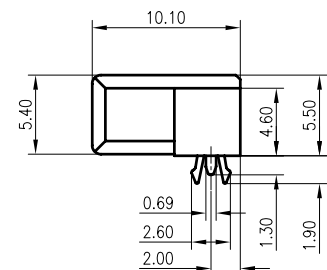

A B C D E F

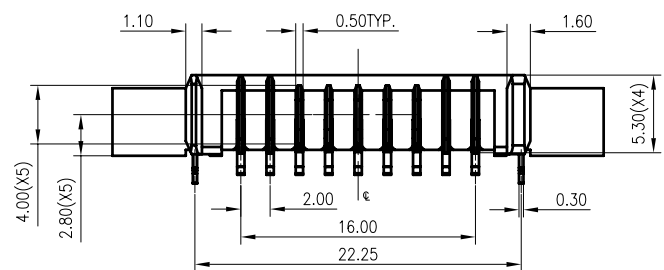

- NOTES:
- MATERIAL:
 - HOUSING: THERMOPLASTIC, HIGH TEMP.,UL94V-0.
 - CONTACT: COPPER ALLOY.
 - HOOK: COPPER ALLOY.
 - SCREW: COPPER ALLOY.
 - FINISH:
 - CONTACT & SOLDER:
 - 1u" GOLD FLASH ON CONTACT AND SOLDER.
 - 50~100u" MIN. NICKEL UNDERPLATING OVERALL.
 - HOOK:
 - 50~100u" MIN. NICKEL UNDER PLATING OVER ALL
 - 100u" MIN. MATT TIN PLATING OVER ALL
 - REFLOW SOLDER CAPABLE TO 260°C PER ACES SPEC.
 - SPEC. PLS REFER TO PS-53007-XXXX-XXX
 - PACKAGE PLS REFER TO 53049-XXXX-XX-TRP
 - PART NUMBER

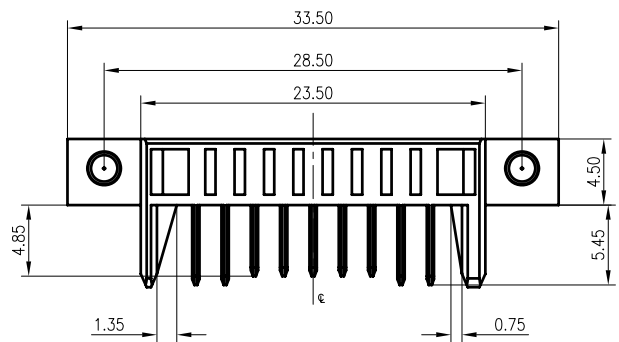
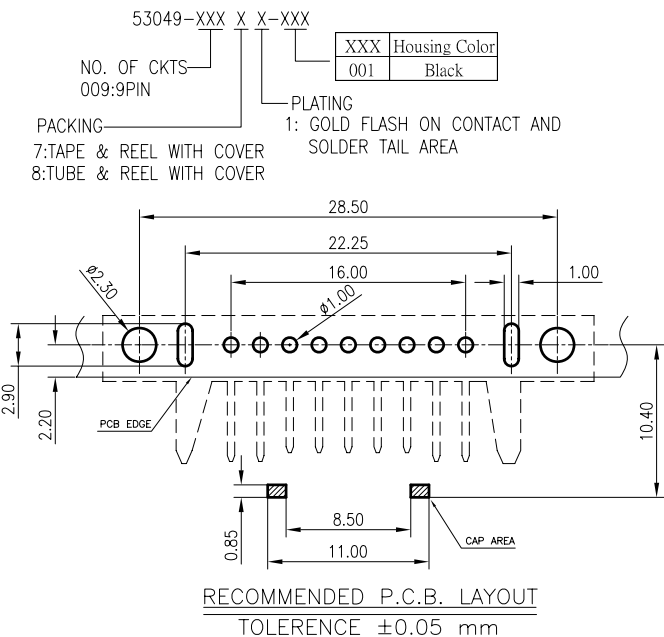

53049-XXX X X-XXX

XXX	Housing Color
001	Black

NO. OF CKTS: 009:9PIN
PACKING: 7:TAPE & REEL WITH COVER, 8:TUBE & REEL WITH COVER
PLATING: 1: GOLD FLASH ON CONTACT AND SOLDER TAIL AREA

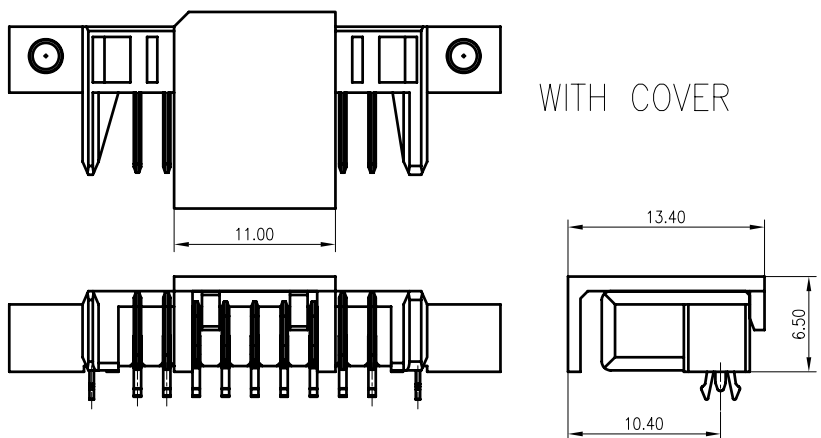

一般公差 TOLERANCES X. ±0.5 XX ±0.15 X ±0.25 XXX ±0.1 ANGLES ±2°		宏致電子股份有限公司 Aces Electronics Co.,Ltd.	
檢驗尺寸標示 SYMBOLS Ⓞ Ⓢ INDICATE CLASSIFICATION DIMENSION Ⓞ MARK IS CRITICAL DIM. Ⓢ MARK IS MAJOR DIM.	品名 (TITLE) 2.00mm Battery Conn. Male DIP R/A Type H=5.50 圖號 (DWG NO.) 53049-XXXXX-XXX	製圖 (DR) 13/04/16 許紅理 審核 (CHKD) CARL 核准 (APPD) Jason	張數 (SHEET) 1 OF 1 尺寸 (SIZE) A4 版次 (REV) 0
表面處理 (FINISH)	比例 (SCALE) 1:1	單位 (UNITS) mm	

A B C D E F