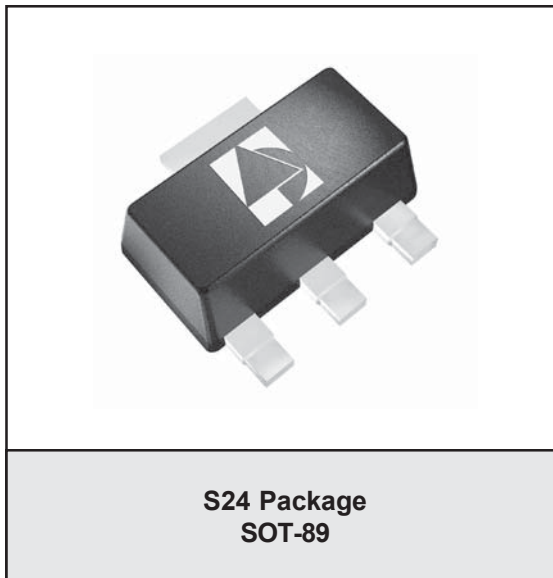

**FEATURES**

- 12 dB Gain
- 50 to 1000 MHz Frequency Range
- Noise Figure: 2.3 dB
- Single +5 V Supply
- Small SOT-89 Package
- RoHS Compliant/Lead-free

**APPLICATIONS**

- Low Noise Amplifier for CATV Set-Top Boxes
- CATV Drop Amplifier

**PRODUCT DESCRIPTION**

The ADA1200 is a highly linear amplifier developed to meet the stringent requirements of CATV systems. Offered in a low cost SOT-89 package, this GaAs MESFET design offers low noise and low distortion over a wide frequency range. The device is ideally

suited for applications as a Low Noise Amplifier in CATV Set-Top Boxes, and as a Drop Amplifier in CATV distribution systems. The ADA1200 requires a single +5 V supply, and typically consumes 400 mW of power.

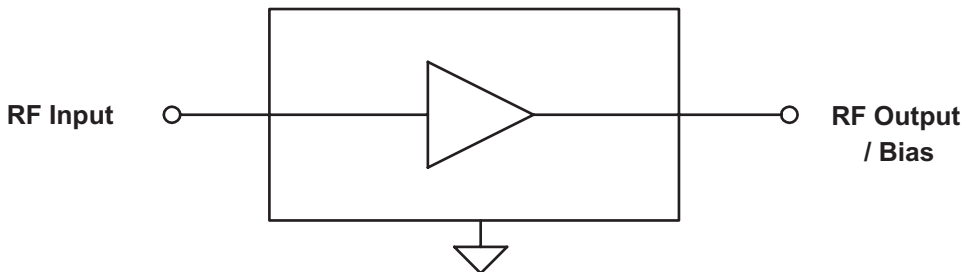

**Figure 1: Block Diagram**

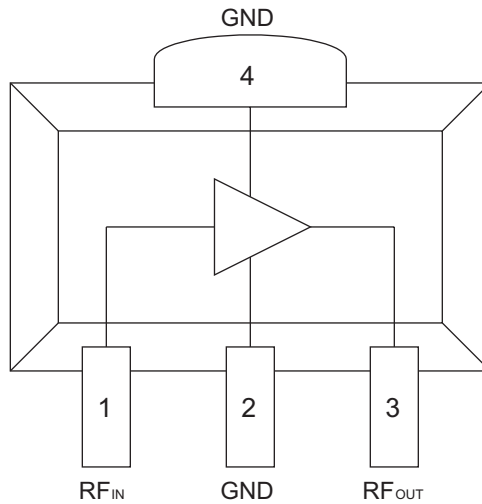

Figure 2: Pinout

Table 1: Pin Description

PIN	NAME	DESCRIPTION
1	RF <sub>IN</sub>	RF Input
2	GND	Ground
3	RF <sub>OUT</sub>	RF Output / Bias
4	GND	Ground

## ELECTRICAL CHARACTERISTICS

Table 2: Absolute Minimum and Maximum Ratings

PARAMETER	MIN	MAX	UNIT
Device Voltage ( $V_{CC}$ )	0	+9	VDC
RF Input Power ( $P_{IN}$ )	-	+10	dBm
Storage Temperature ( $T_{STG}$ )	-40	+150	°C
Channel Temperature	-	+150	°C

Stresses in excess of the absolute ratings may cause permanent damage. Functional operation is not implied under these conditions. Exposure to absolute ratings for extended periods of time may adversely affect reliability.

Table 3: Operating Ranges

PARAMETER	MIN	TYP	MAX	UNIT
RF Input/Output Frequency (f)	50	-	1000	MHz
Supply Voltage ( $V_{DD}$ )	-	+5	-	VDC
Case Temperature ( $T_C$ )	-40	-	+100	°C

The device may be operated safely over these conditions; however, parametric performance is guaranteed only over the conditions defined in the electrical specifications.

**Table 4: Electrical Specifications**

( $T_A = +25\text{ }^\circ\text{C}$ ,  $V_{DD} = +5\text{ VDC}$ ,  $f = 50\text{ to }860\text{ MHz}$ ,  $75\text{ }\Omega$  system, ref. Figure 3)

PARAMETER	MIN	TYP	MAX	UNIT
Gain	10.5	12	13	dB
Noise Figure	-	2.3	3.5	dB
CSO <sup>(1)</sup> Ch 5 & 6 (77.25 MHz & 83.25 MHz)	-	-	-57	dBc
CSO <sup>(1)</sup> all other channels	-	-	-59	dBc
CTB <sup>(1)</sup>	-	-75	-64	dBc
XMOD <sup>(1)</sup>	-	-73	-63	dBc
OIP2 <sup>(2)</sup>	+52	-	-	dBm
3-Tone OIP3 <sup>(3)</sup>	+32	-	-	dBm
Input Return Loss	-	-25	-16	dB
Output Return Loss	-	-25	-16	dB
Thermal Resistance ( $\theta_{JC}$ )	-	-	50	$^\circ\text{C/W}$
Supply Current	-	80	100	mA

**Notes:**

- (1) 132 total channels, flat input; 110 analog channels @ +15 dBmV per channel; 22 digital channels (757.25 MHz to 871.25 MHz) @ 6 dB below analog channels; Standard NTSC channel plan (55.25 MHz to 871.25 MHz)
- (2) Two tones, -10 dBm per tone at input (439.25 MHz and 853.25 MHz);  $IMD_2$  measured at 414.00 MHz.
- (3) Three tones, -10 dBm per tone at input (67.25, 439.25 MHz, 871.25 MHz);  $IMD_3$  measured at 481.25 MHz (note that the related 2-tone IP3 is 3 dB higher than the 3-tone IP3).

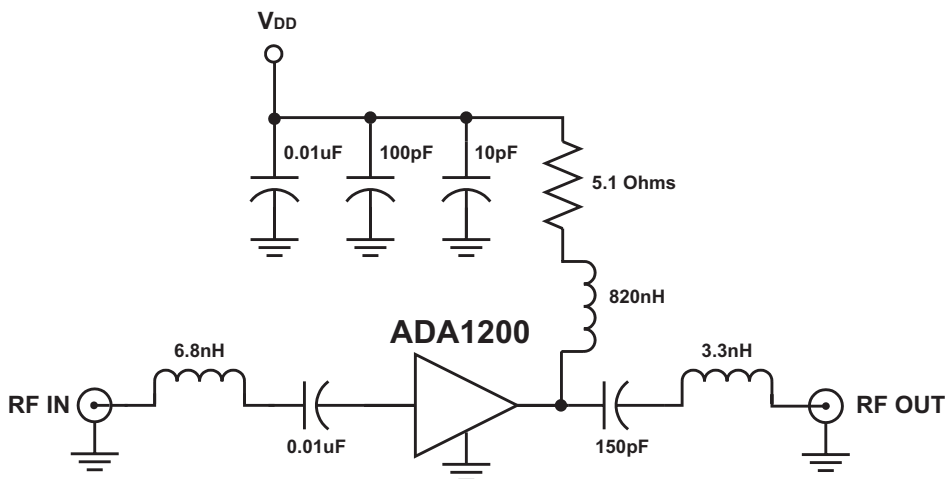

**Figure 3: Test Circuit**

PERFORMANCE DATA

**Figure 4: Gain vs. Frequency**  
 ( $T_A = +25\text{ }^\circ\text{C}$ ,  $V_{DD} = +5\text{ V}$ ,  $75\ \Omega$  System)

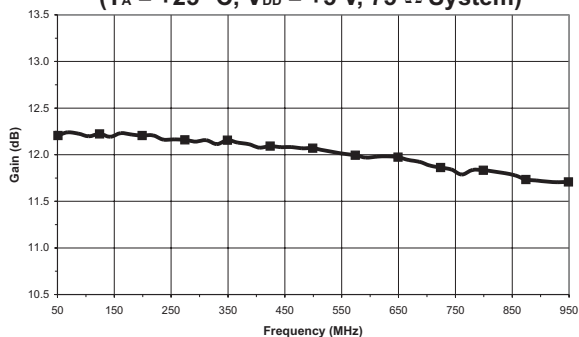

**Figure 5: Noise Figure vs. Frequency**  
 ( $T_A = +25\text{ }^\circ\text{C}$ ,  $V_{DD} = +5\text{ V}$ ,  $75\ \Omega$  System)

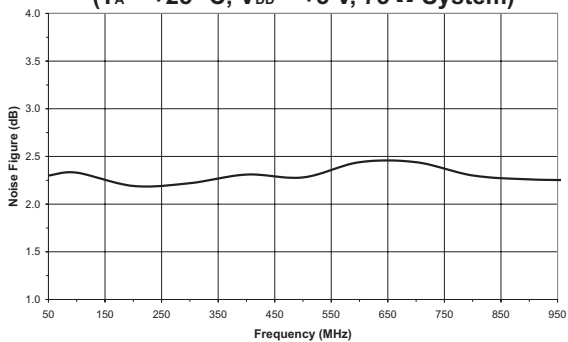

**Figure 6: Input Return Loss vs. Frequency**  
 ( $T_A = +25\text{ }^\circ\text{C}$ ,  $V_{DD} = +5\text{ V}$ ,  $75\ \Omega$  System)

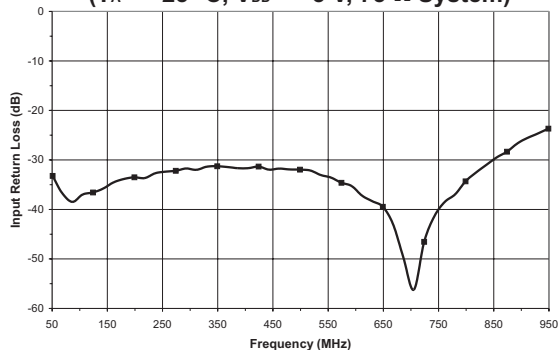

**Figure 7: Output Return Loss vs. Frequency**  
 ( $T_A = +25\text{ }^\circ\text{C}$ ,  $V_{DD} = +5\text{ V}$ ,  $75\ \Omega$  System)

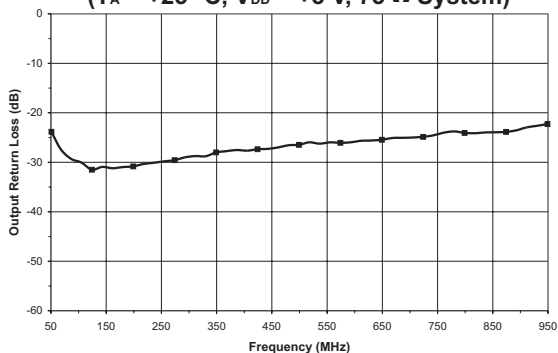

**Figure 8: CTB vs. Frequency**  
 (TA = +25°C, VDD = +5 V, 132 analog channels,  
 +15 dBmV input power per channel)

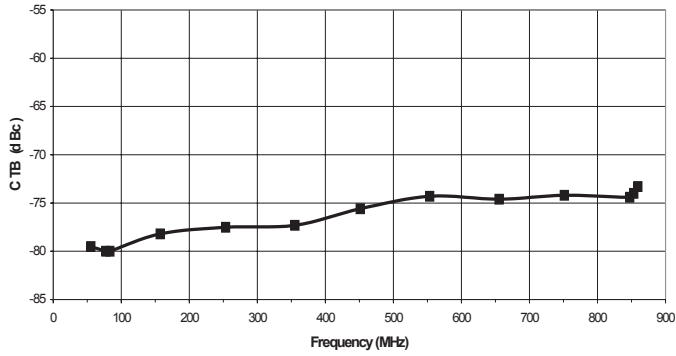

**Figure 9: CSO vs. Frequency**  
 (TA = +25°C, VDD = +5 V, 132 analog channels,  
 +15 dBmV input power per channel)

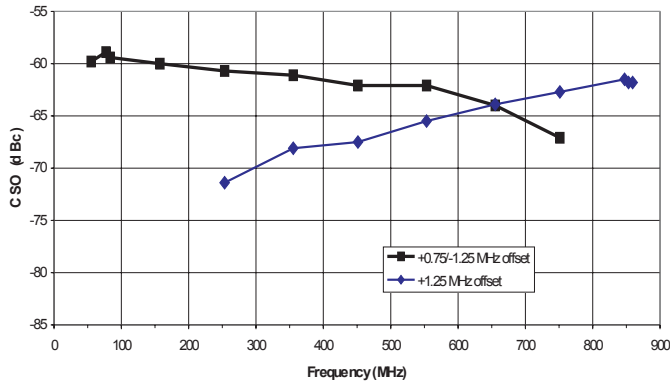

**Figure 10: XMOD vs. Frequency**  
 (TA = +25°C, VDD = +5 V, 132 analog channels,  
 +15 dBmV input power per channel)

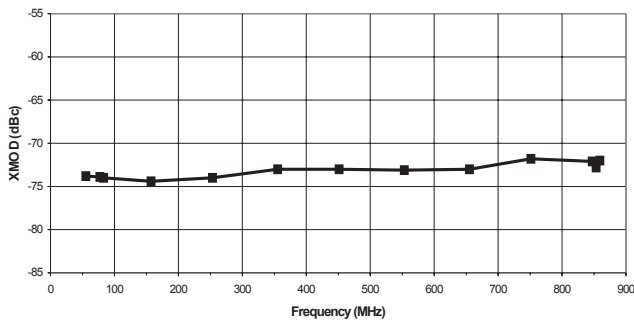

## APPLICATION INFORMATION

**Table 5: In Circuit S-Parameters**  
 (T<sub>A</sub> = +25 °C, V<sub>DD</sub> = +5.0 VDC, 75 Ω system, ref. Figure 3)

FREQ	S11		S21		S12		S22		K Factor
	MHz	DB	ANG	DB	ANG	DB	ANG	DB	
25	-17.8	-108.4	11.6	-140.4	-17.2	37.8	-13.0	-146.5	1.01
50	-31.1	-103.9	12.3	-171.3	-16.5	8.8	-23.9	-170.5	1.12
100	-37.9	-37.5	12.3	168.9	-16.5	-8.9	-30.2	-169.0	1.12
150	-35.8	-8.2	12.3	155.8	-16.5	-20.6	-31.0	-155.9	1.12
200	-35.2	-1.9	12.2	144.2	-16.6	-30.4	-30.6	-153.9	1.13
250	-33.6	-1.0	12.2	133.3	-16.6	-39.9	-30.1	-157.2	1.13
300	-32.7	-1.6	12.2	122.9	-16.7	-49.2	-29.1	-160.8	1.13
350	-31.9	-3.2	12.1	112.5	-16.7	-58.0	-28.0	-164.1	1.14
400	-32.0	-11.4	12.1	102.1	-16.7	-66.9	-27.4	-167.7	1.14
450	-32.8	-17.0	12.1	91.8	-16.8	-75.8	-27.0	-172.2	1.15
500	-33.2	-23.2	12.1	81.6	-16.8	-84.8	-26.3	-175.8	1.15
550	-35.9	-33.7	12.0	71.4	-16.9	-93.7	-26.3	-112.0	1.16
600	-40.1	-57.8	12.0	61.2	-17.0	-102.6	-25.7	124.4	1.16
650	-46.2	-113.4	12.0	50.8	-17.1	-111.6	-25.3	174.1	1.17
700	-38.1	145.8	11.9	40.5	-17.1	-121.3	-25.0	39.0	1.18
750	-31.0	127.6	11.8	30.0	-17.2	-129.9	-25.0	174.8	1.19
800	-28.2	117.1	11.8	20.1	-17.3	-138.1	-23.6	163.8	1.20
850	-25.0	107.3	11.7	9.6	-17.5	-147.6	-23.3	166.6	1.21
900	-22.4	97.7	11.7	-0.7	-17.5	-156.9	-23.2	167.7	1.22
950	-20.3	90.3	11.6	-11.4	-17.6	-166.0	-22.2	164.1	1.23
1000	-18.3	82.4	11.5	-22.1	-17.8	-175.6	-20.9	160.4	1.24

PACKAGE OUTLINE

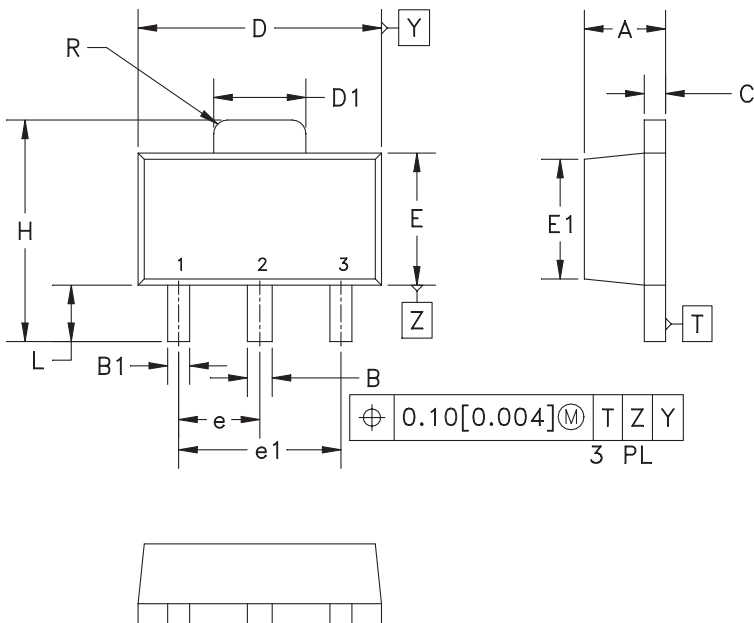

S <sub>MPO</sub>	MILLIMETERS		INCHES		NOTE
	MIN.	MAX.	MIN.	MAX.	
A	1.40	1.60	0.055	0.063	-
B	0.44	0.56	0.017	0.022	-
B1	0.36	0.48	0.014	0.019	3
C	0.35	0.44	0.014	0.017	-
D	4.40	4.60	0.173	0.181	-
D1	1.62	1.83	0.064	0.072	-
E	2.29	2.60	0.090	0.102	-
E1	2.13	2.29	0.084	0.090	4
e	1.50 BSC		0.059 BSC		-
e1	3.00 BSC		0.118 BSC		-
H	3.94	4.25	0.155	0.167	-
L	0.89	1.20	0.035	0.047	-
R	-	0.25	-	0.010	-

NOTES:

1. CONTROLLING DIMENSIONS: MILLIMETERS.
2. DIMENSIONS DO NOT INCLUDE END FLASH, MOLD FLASH OR MATERIAL PROTRUSIONS.
3. DIMENSION B1, 2 PLACES.
4. DIMENSION E1 – REFERENCE ONLY.
5. REFERENCE JEDEC TO-243 (AA).

Figure 11: S24 Package Outline – SOT-89

TOP BRAND

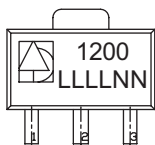

NOTES:

1. ANADIGICS LOGO SIZE: X=0.040±0.010 Y=0.048±0.010
2. PART NUMBER: FOUR NUMERIC CHARACTERS
3. WAFER LOT NUMBER: LLLL= FOUR NUMERIC CHARACTERS  
NN= TWO ALPHABETIC CHARACTERS
4. TYPE : ELITE  
SIZE : 2-POINT  
COLOR : LASER

Figure 12: Branding Specification



NOTES



NOTES

**ORDERING INFORMATION**

PART NUMBER	TEMPERATURE RANGE	PACKAGE DESCRIPTION	COMPONENT PACKAGING
ADA1200S24GQ1	-40 to +100°C	SOT-89 Package	1,000 piece Tape and Reel

**ANADIGICS, Inc.**

141 Mount Bethel Road  
 Warren, New Jersey 07059, U.S.A.  
 Tel: +1 (908) 668-5000  
 Fax: +1 (908) 668-5132

URL: <http://www.anadigics.com>  
 E-mail: [Mktg@anadigics.com](mailto:Mktg@anadigics.com)

**IMPORTANT NOTICE**

ANADIGICS, Inc. reserves the right to make changes to its products or to discontinue any product at any time without notice. The product specifications contained in Advanced Product Information sheets and Preliminary Data Sheets are subject to change prior to a product's formal introduction. Information in Data Sheets have been carefully checked and are assumed to be reliable; however, ANADIGICS assumes no responsibilities for inaccuracies. ANADIGICS strongly urges customers to verify that the information they are using is current before placing orders.

**WARNING**

ANADIGICS products are not intended for use in life support appliances, devices or systems. Use of an ANADIGICS product in any such application without written consent is prohibited.

This datasheet has been download from:

[www.datasheetcatalog.com](http://www.datasheetcatalog.com)

Datasheets for electronics components.