

150mA/300mA Low Dropout Linear Regulator with 1% Output Accuracy

FEATURES

- Low Dropout Voltage of 130mV at 100mA Output Current (5V Output Version).
- Guaranteed 150mA/300mA Output Current.
- Internal 1.3Ω P-MOSFET Draws no Base Current.
- Low Ground Current: 55μA.
- 1% Accuracy Output Voltage of 3.3V/5V.
- Input Voltage Range up to 12V (5V Output Version).
- Extremely Tight Load and Line Regulation.
- Fast Transient Response.
- Current Limiting and Thermal Protection.

APPLICATIONS

- LAN Cards.
- Wireless Communication Systems.
- Battery Powered Systems.

DESCRIPTION

AIC1721/1721D is a 150mA/300mA low dropout linear regulator. The superior characteristics of the AIC1721/1721D include zero-base current loss, very low dropout voltage, and 1% accuracy output voltage. Typical ground current remains approximately at 55μA, when loading ranges from zero to maximum. When output current is 100mA, in comparison with bipolar counterpart, dropout voltage of AIC1721/1721D is substantially lower (130mV for the AIC1721-5/1721D-5, and 180mV for the AIC1721/1721D). Built-in output current limiting and thermal limiting provide maximal protection to the AIC1721/1721D against fault conditions.

The AIC1721 and AIC1721D are available in popular SOT-89 and TO-92 packages.

TYPICAL APPLICATION CIRCUIT

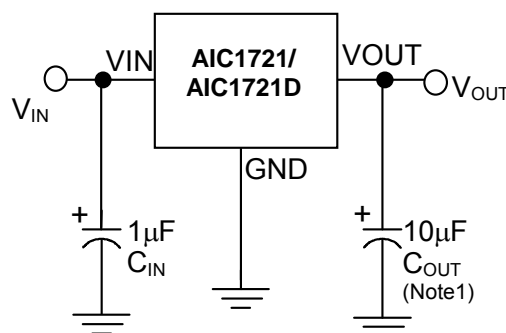

Low Dropout Linear Regulator

ORDERING INFORMATION

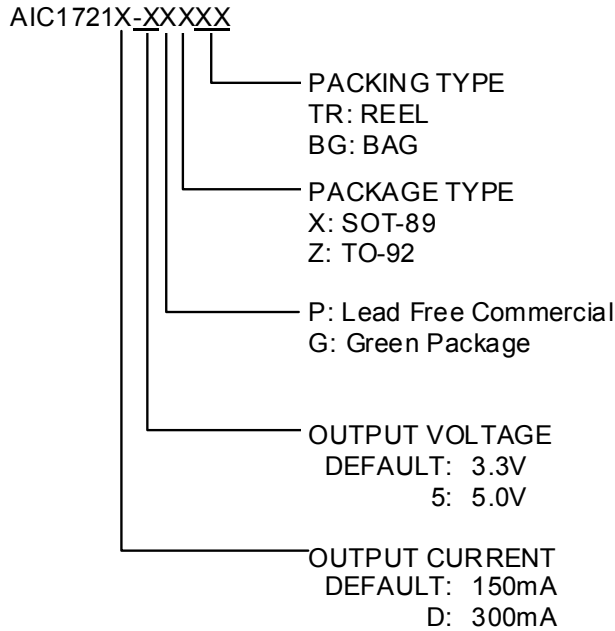

Example: AIC1721PXTR
 → 150mA, 3.3V Version, in SOT-89 Lead Free Package & Tape & Reel Packing Type

AIC1721D-5GZTR
 → 300mA, 5.0V Version, in TO-92 Green Package & Tape & Reel Packing Type

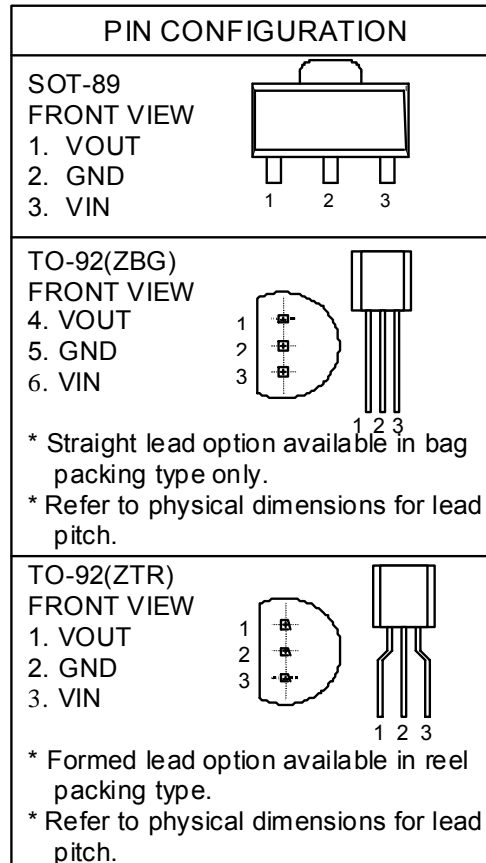

● SOT89 Marking

Part No.	PX	GX
AIC1721	AF33P	AF33G
AIC1721-5	AF50P	AF50G

Part No.	PX	GX
AIC1721D	AG33P	AG33G
AIC1721D-5	AG50P	AG50G

■ ABSOLUTE MAXIMUM RATINGS

Input Supply Voltage	-0.3~12V
Operating Junction Temperature Range	-40°C~ 85°C
Maximum Junction Temperature	125°C
Storage Temperature Range	-65°C~150°C
Lead Temperature (Soldering) 10 sec.	260°C
Thermal Resistance Junction to Case, $R_{\theta_{JC}}$	SOT-89.....	30°C /W
	TO-92.....	120°C /W
Thermal Resistance Junction to Ambient, $R_{\theta_{JA}}$	SOT-89.....	160°C /W
(Assume no ambient airflow, no heatsink)	TO-92.....	150°C /W

Absolute Maximum Ratings are those values beyond which the life of a device may be impaired.

■ TEST CIRCUIT

Refer to the TYPICAL APPLICATION CIRCUIT

■ **ELECTRICAL CHARACTERISTICS** ($T_A=25^{\circ}\text{C}$, $C_{IN}=1\mu\text{F}$, $C_{OUT}=10\mu\text{F}$, unless otherwise specified.)(Note2)

PARAMETER	TEST CONDITIONS	MIN.	TYP.	MAX.	UNIT
Output Voltage	AIC1721/1721D-5 $V_{IN}=5.5\sim 12\text{V}$, $I_{OUT}=0\text{mA}$	4.950	5.0	5.050	V
	AIC1721/1721D $V_{IN}=3.6\sim 12\text{V}$, $I_{OUT}=0\text{mA}$	3.267	3.3	3.333	
Output Voltage Temperature Coefficiency	(Note 3)		50	150	PPM/ $^{\circ}\text{C}$
Line Regulation	$I_{OUT}=1\text{mA}$ AIC1721/1721D-5 $V_{IN}=5.5\sim 12\text{V}$		3	10	mV
	AIC1721/1721D $V_{IN}=3.6\sim 12\text{V}$		3	10	
Load Regulation (Note 4)	AIC1721-5 $V_{IN}=7\text{V}$, $I_{OUT}=0.1\sim 150\text{mA}$		7	15	mV
	AIC1721D-5 $V_{IN}=7\text{V}$, $I_{OUT}=0.1\sim 300\text{mA}$		7	25	
	AIC1721 $V_{IN}=5\text{V}$, $I_{OUT}=0.1\sim 150\text{mA}$		7	15	
	AIC1721D $V_{IN}=5\text{V}$, $I_{OUT}=0.1\sim 300\text{mA}$		7	25	
Current Limit (Note 5)	AIC1721-5 $V_{IN}=7\text{V}$, $V_{OUT}=0\text{V}$	300	440		mA
	AIC1721 $V_{IN}=5\text{V}$, $V_{OUT}=0\text{V}$	300	440		
	AIC1721D-5 $V_{IN}=7\text{V}$, $V_{OUT}=0\text{V}$	300	440		
	AIC1721D $V_{IN}=5\text{V}$, $V_{OUT}=0\text{V}$	300	440		
Dropout Voltage (Note 6)	AIC1721-5 $I_{OUT}=150\text{mA}$		200	300	mV
	AIC1721 $I_{OUT}=150\text{mA}$		270	370	
	AIC1721D-5 $I_{OUT}=300\text{mA}$		400	500	
	AIC1721D $I_{OUT}=300\text{mA}$		540	640	
Ground Current	$I_{OUT}=0.1\text{mA}\sim I_{MAX}$ AIC1721/1721D-5 $V_{IN}=5.5\sim 12\text{V}$		55	80	μA
	AIC1721/1721D $V_{IN}=4\sim 12\text{V}$		55	80	

Note 1: To avoid output oscillation, aluminum electrolytic output capacitor is recommended and ceramic capacitor is not suggested.

Note 2: Specifications are production tested at $T_A=25^{\circ}\text{C}$. Specifications over the -40°C to 85°C operating temperature range are assured by design, characterization and correlation with Statistical Quality Controls (SQC).

Note 3: Guaranteed by design.

Note 4: Regulation is measured at a constant junction temperature, which results from the use of pulse testing.

Note 5: Current limit is measured by pulse testing.

Note 6: Dropout voltage is defined as voltage differential at which the output voltage drops 100mV with an initial 1V differential between input and output.

TYPICAL PERFORMANCE CHARACTERISTICS

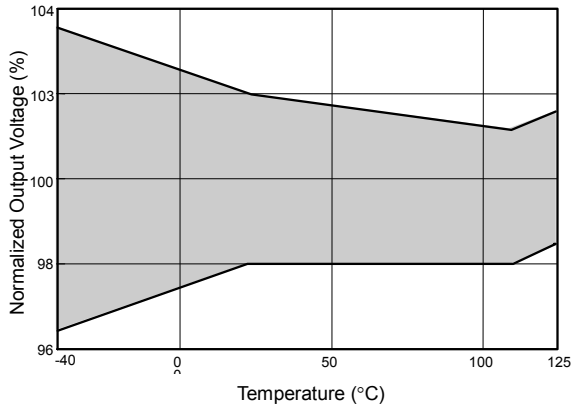

Fig. 1 Output Voltage vs. Temperature

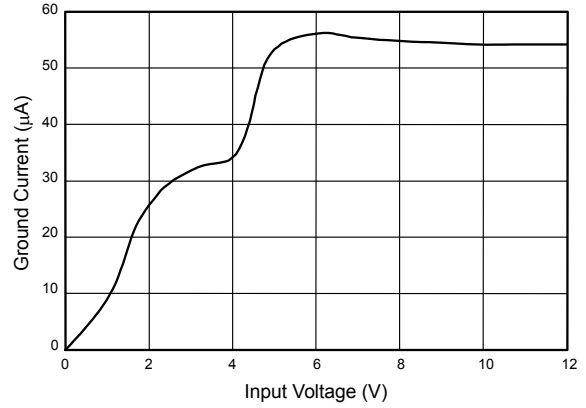

Fig. 2 Ground Current vs. Input Voltage

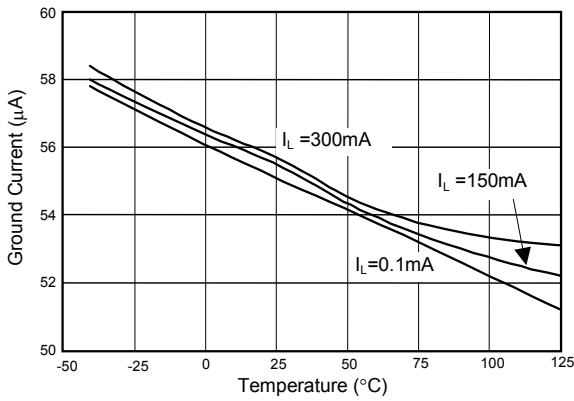

Fig. 3 Ground Current vs. Temperature

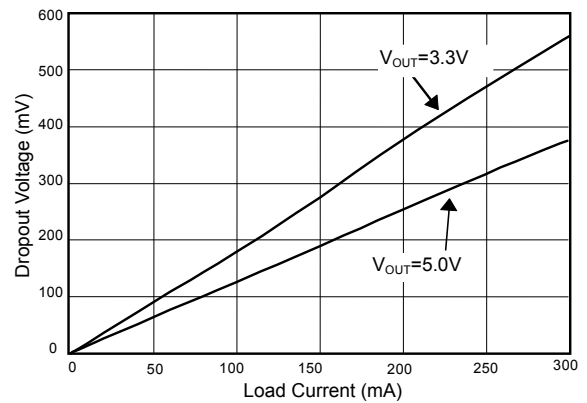

Fig. 4 Dropout Voltage vs. Load Current

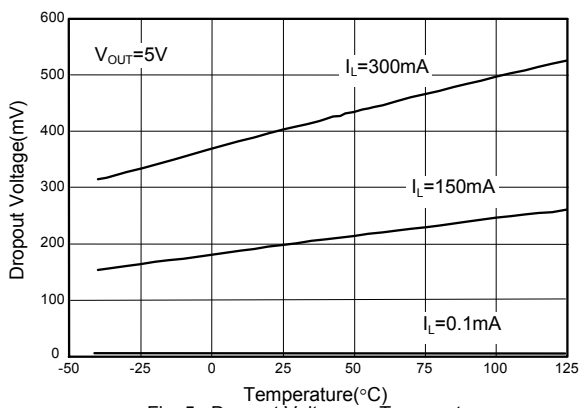

Fig. 5 Dropout Voltage vs Temperature

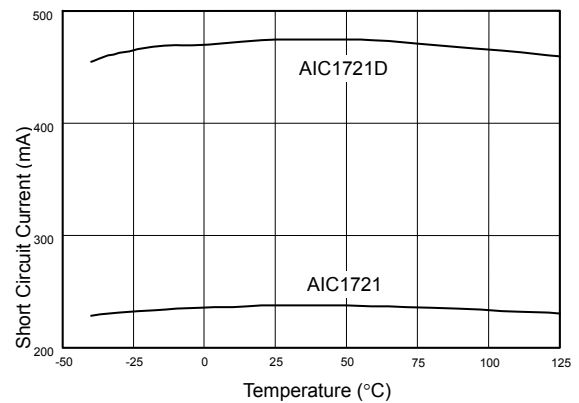

Fig. 6 Short Circuit Current vs. Temperature

TYPICAL PERFORMANCE CHARACTERISTICS (Continued)

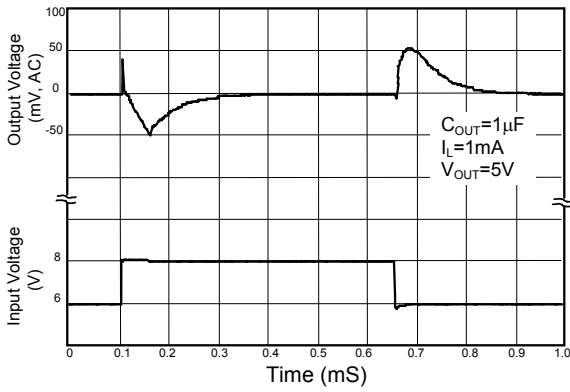

Fig. 7 Line Transient Response

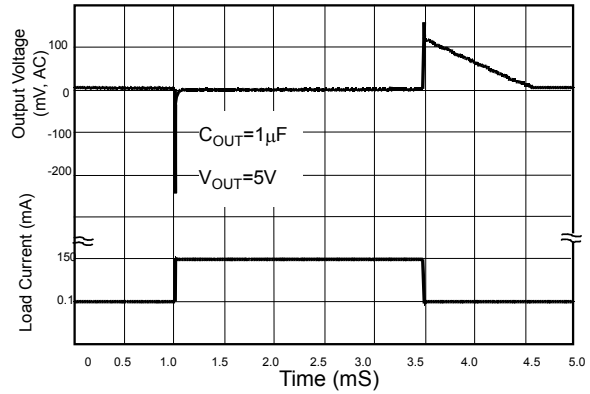

Fig. 8 Load Transient Response

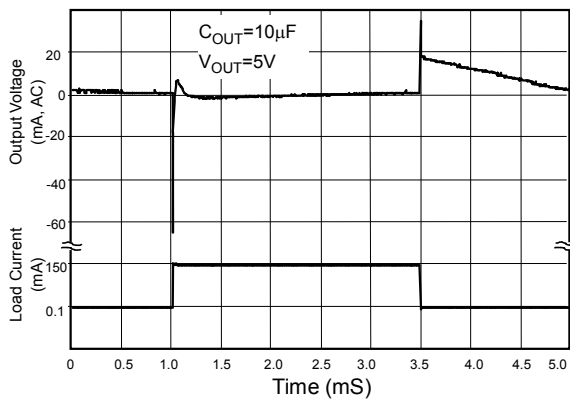
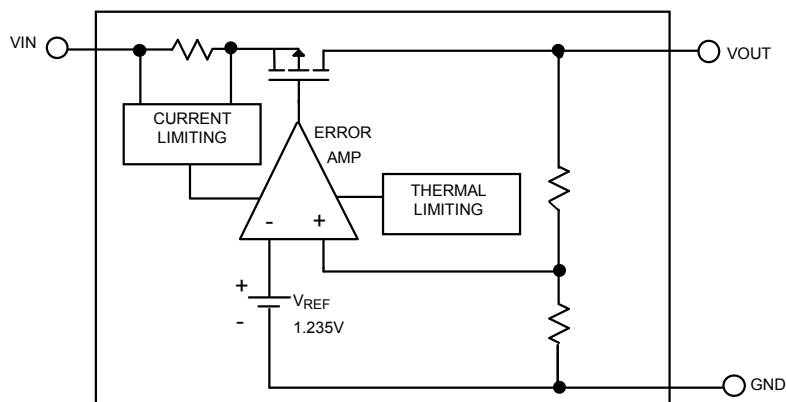

Fig. 9 Load Transient Response

BLOCK DIAGRAM



■ PIN DESCRIPTIONS

VOUT PIN - Output pin.

GND PIN - Power GND.

VIN PIN - Power Supply Input.

■ APPLICATION INFORMATION

INPUT-OUTPUT CAPACITORS

Linear regulators require input and output capacitors to maintain stability. Input capacitor at 1 μ F with a 10 μ F aluminum electrolytic output capacitor is recommended.

POWER DISSIPATION

The AIC1721/1721D obtains thermal-limiting circuitry, which is designed to protect the device against overload condition. For continuous load condition, maximum rating of junction temperature must not be exceeded. It is important to pay more attention in thermal resistance. It includes junction to case, junction to ambient. The maximum power dissipation of AIC1721/1721D depends on the thermal resistance of its case and circuit board, the temperature difference between the die junction and ambient air, and the rate of airflow. The rate of temperature rise is greatly affected by the mounting pad configuration on the PCB, the board material, and the ambient temperature. When the IC mounting with good thermal

conductivity is used, the junction temperature will be low even when large power dissipation applies.

The power dissipation across the device is

$$P = I_{OUT} (V_{IN} - V_{OUT}).$$

The maximum power dissipation is:

$$P_{MAX} = \frac{(T_{J-max} - T_A)}{R\theta_{JA}}$$

Where T_{J-max} is the maximum allowable junction temperature (125°C), and T_A is the ambient temperature suitable in application.

As a general rule, the lower temperature is, the better reliability of the device is. So the PCB mounting pad should provide maximum thermal conductivity to maintain low device temperature.

GND pin performs a dual function for providing an electrical connection to ground and channeling heat away. Therefore, connecting the GND pin to ground with a large pad or ground plane would increase the power dissipation and reduce the device temperature.

■ PHYSICAL DIMENSIONS (unit: mm)

● SOT-89

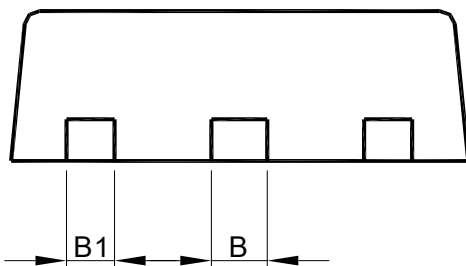
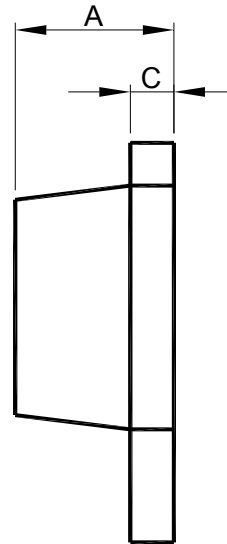
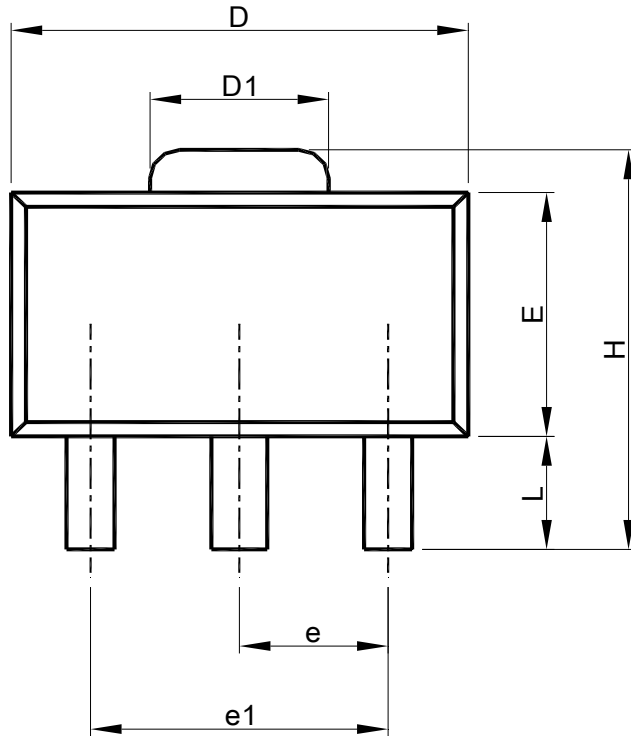

SYMBOL	SOT-89	
	MILLIMETERS	
	MIN.	MAX.
A	1.40	1.60
B	0.44	0.56
B1	0.36	0.48
C	0.35	0.44
D	4.40	4.60
D1	1.50	1.83
E	2.29	2.60
e	1.50 BSC	
e1	3.00 BSC	
H	3.94	4.25
L	0.89	1.20

- Note: 1. Refer to JEDEC TO-243AA.
 2. Dimension "D" does not include mold flash, protrusions or gate burrs. Mold flash, protrusion or gate burrs shall not exceed 6 mil per side.
 3. Dimension "E" does not include inter-lead flash or protrusions.
 4. Controlling dimension is millimeter, converted inch dimensions are not necessarily exact.

- TO-92 (Straight lead option available in Bag packing type only)

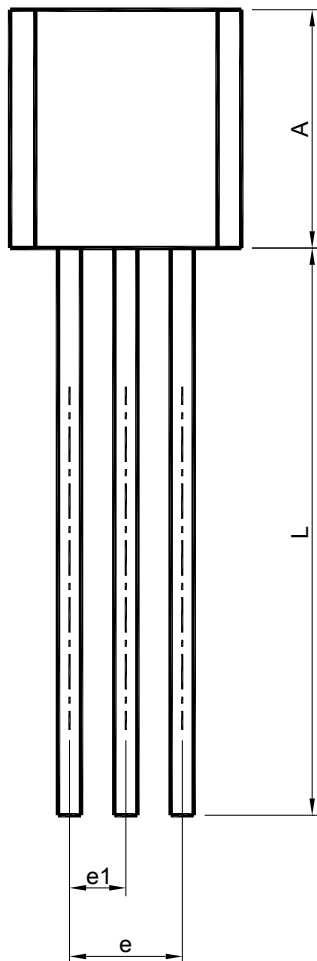
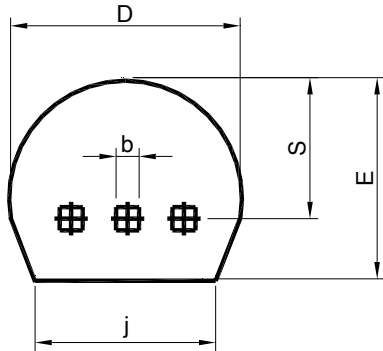

SYMBOL	TO-92	
	MILLIMETERS	
	MIN.	MAX.
A	4.32	5.33
b	0.36	0.47
D	4.45	5.20
E	3.18	4.19
e	2.42	2.66
e1	1.15	1.39
j	3.43	
L	12.70	
S	2.03	2.66

- Note: 1. Refer to JEDEC TO-226.
 2. Dimension "D" does not include mold flash, protrusions or gate burrs. Mold flash, protrusion or gate burrs shall not exceed 6 mil per side .
 3. Dimension "A" does not include inter-lead flash or protrusions.
 4. Controlling dimension is millimeter, converted inch dimensions are not necessarily exact.

● TO-92 (Formed lead option available in Reel packing)

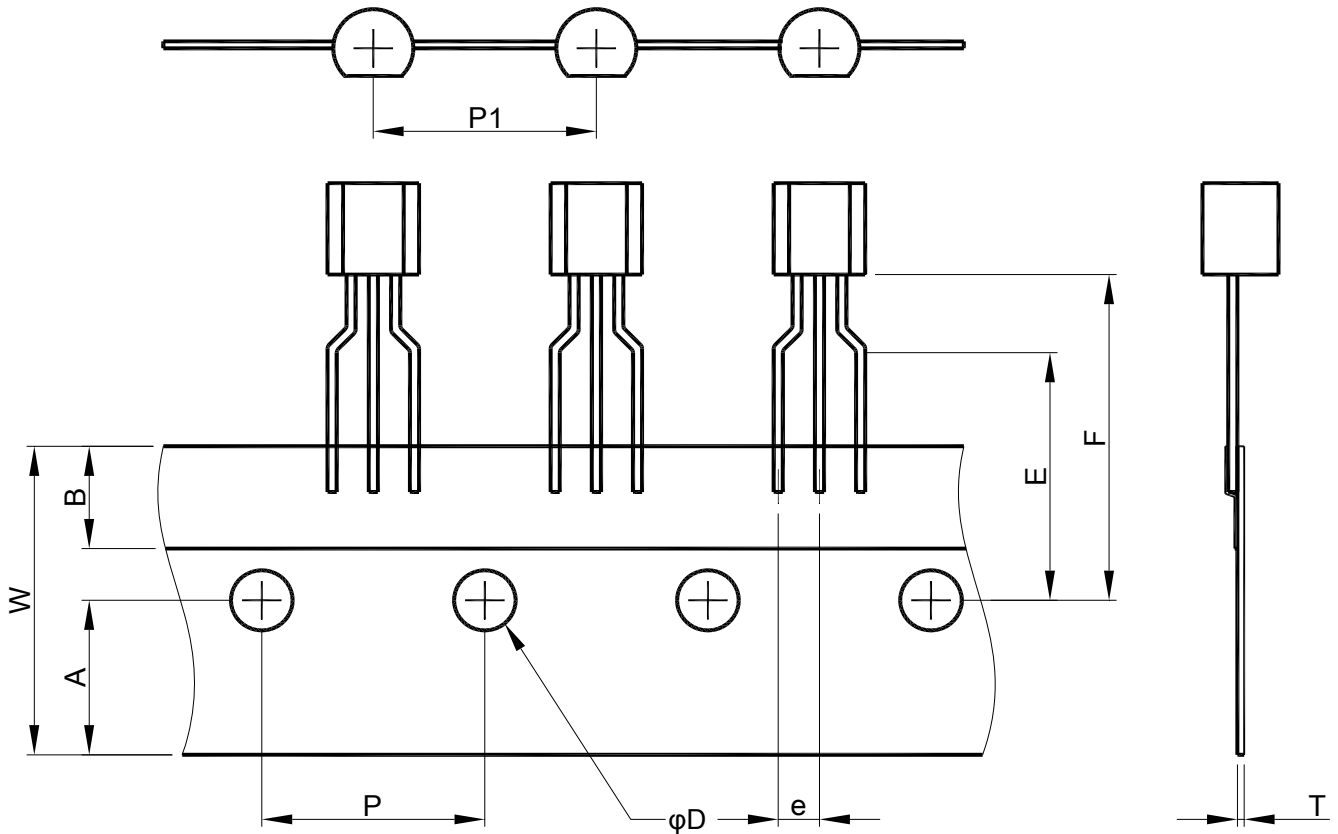

SYMBOL	W	A	B	E	F
SPEC.	18.0±0.2	9.0±0.2	6.0±0.20	16.0±0.5	19.0±0.5
SYMBOL	P	P1	D	e	T
SPEC.	12.7 BSC	12.7 BSC	4.0±0.2	2.5 BSC	0.6±0.1

Note:

Information provided by AIC is believed to be accurate and reliable. However, we cannot assume responsibility for use of any circuitry other than circuitry entirely embodied in an AIC product; nor for any infringement of patents or other rights of third parties that may result from its use. We reserve the right to change the circuitry and specifications without notice.

Life Support Policy: AIC does not authorize any AIC product for use in life support devices and/or systems. Life support devices or systems are devices or systems which, (i) are intended for surgical implant into the body or (ii) support or sustain life, and whose failure to perform, when properly used in accordance with instructions for use provided in the labeling, can be reasonably expected to result in a significant injury to the user.