

LDMOS L-band radar transistor

Datasheet - preliminary data

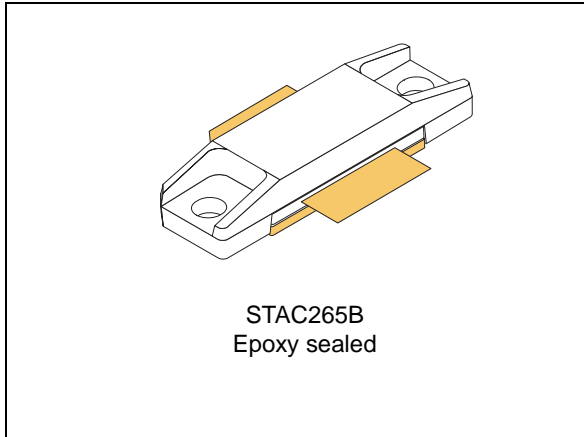
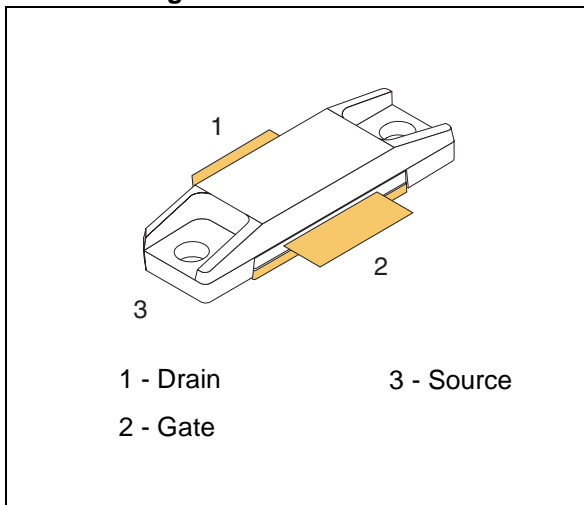

Figure 1. Pin connection



Features

- Excellent thermal stability
- Common source configuration push-pull
- $P_{OUT} = 250\text{ W}$ with 14 dB gain over 1200 - 1400 MHz
- ST air cavity / STAC[®] package

Description

The STAC1214-250 is a common source N-channel enhancement-mode lateral field-effect RF power transistor designed for L band radar applications.

Table 1. Device summary

Order code	Package	Branding
STAC1214-250	STAC265B	1214-250

Contents

1	Electrical data	3
	1.1 Maximum ratings	3
	1.2 Thermal data	3
2	Electrical characteristics	4
	2.1 Static	4
	2.2 Dynamic	4
3	Impedance data	5
4	Typical performances	6
5	Circuit and BOM	7
6	Package mechanical data	10
7	Revision history	12

1 Electrical data

1.1 Maximum ratings

$T_{CASE} = 25\text{ °C}$

Table 2. Absolute maximum ratings

Symbol	Parameter	Value	Unit
$V_{(BR)DSS}$	Drain-source voltage	80	V
V_{GS}	Gate-source voltage	± 20	V
P_{DISS}	Power dissipation (@ $T_C = 70\text{ °C}$)	928	W
T_J	Max. operating junction temperature	200	°C
T_{STG}	Storage temperature	- 65 to + 150	°C

1.2 Thermal data

Table 3. Thermal data⁽¹⁾

Symbol	Parameter	Value	Unit
R_{thJC}	Junction - case thermal resistance	0.14	°C/W

1. @100 μ sec - 10%

2 Electrical characteristics

$$T_{\text{CASE}} = + 25 \text{ }^{\circ}\text{C}$$

2.1 Static

Table 4. Static (per section)

Symbol	Test conditions	Min.	Typ.	Max.	Unit
$V_{(\text{BR})\text{DSS}}$	$I_{\text{DS}} = 10 \text{ mA}$	80			V
I_{DSS}	$V_{\text{DS}} = 28 \text{ V}$			2	μA
I_{GSS}	$V_{\text{GS}} = 15 \text{ V}$			1	μA
$V_{\text{GS(Q)}}$	$V_{\text{DS}} = 28 \text{ V}$ $I_{\text{DS}} = 150 \text{ mA}$	2.0		5.0	V
$V_{\text{DS(ON)}}$	$V_{\text{GS}} = 10 \text{ V}$ $I_{\text{DS}} = 6 \text{ A}$		550	600	mV
G_{FS}	$V_{\text{DS}} = 10 \text{ V}$ $I_{\text{DS}} = 6 \text{ A}$	2.5			mho

2.2 Dynamic

$$V_{\text{dd}} = 36 \text{ V}, I_{\text{dq}} = 150 \text{ mA}, \text{ pulse width} = 100 \text{ } \mu\text{s}, \text{ duty cycle} = 10 \%$$

Table 5. Dynamic

Symbol	Test conditions	Min.	Typ.	Max.	Unit
Frequency		1200		1400	MHz
P_{OUT}	$P_{\text{IN}} = 10 \text{ W}$	250	260		W
G_{PS}	$P_{\text{OUT}} = 250 \text{ W}$	13	14		dB
η_{D}	$P_{\text{OUT}} = 250 \text{ W}$	50			%
T_{r}	Rise time - $P_{\text{OUT}} = 250 \text{ W}$			100	ns
T_{f}	Fall Time - $P_{\text{OUT}} = 250 \text{ W}$			30	ns
Droop	$P_{\text{OUT}} = 250 \text{ W}$			0.25	dB
Load mismatch	All phase angles at $P_{\text{OUT}} = 250 \text{ W}$			10:1	VSWR

3 Impedance data

Figure 2. Impedance data

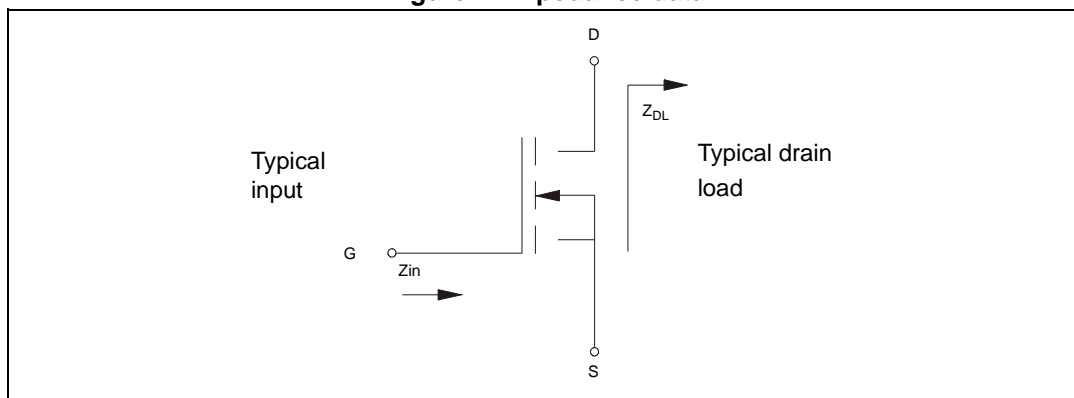

Table 6. Impedance data

Frequency (MHz)	Z_{source} (Ohm)	Z_{load} (Ohm)
1200	1.1+j1.9	1.5+j2.8
1300	1.0+j3.1	1.5+j3.1
1400	1.4+j4.3	1.0+j3.6

4 Typical performances

Figure 3. Output power vs input power

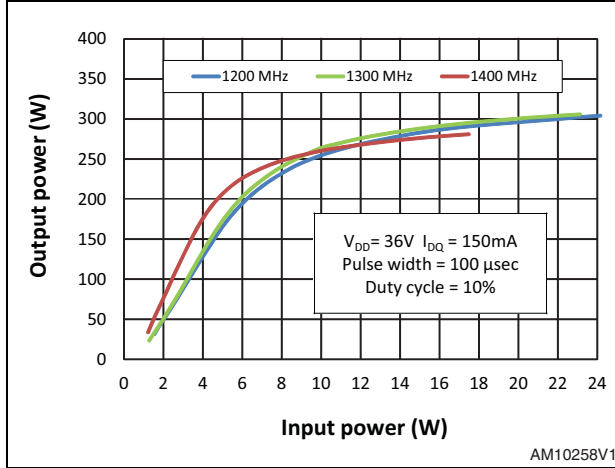

Figure 4. Power gain vs output power

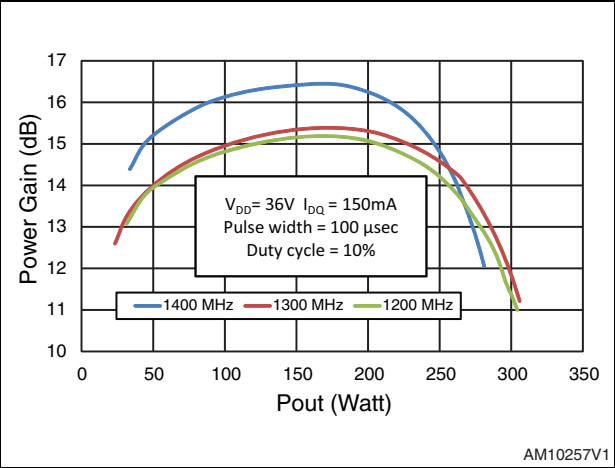

Figure 5. Efficiency vs output power

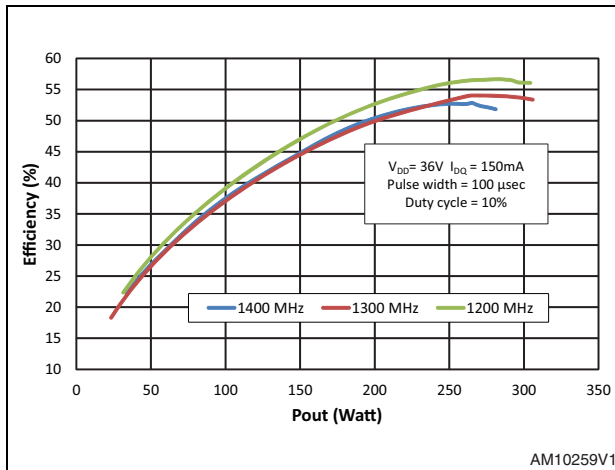
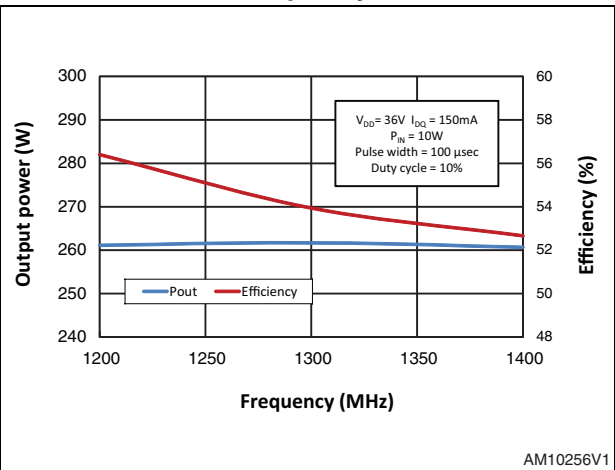

Figure 6. Output power and efficiency vs frequency



5 Circuit and BOM

Figure 7. Broadband 1200-1400 MHz circuit

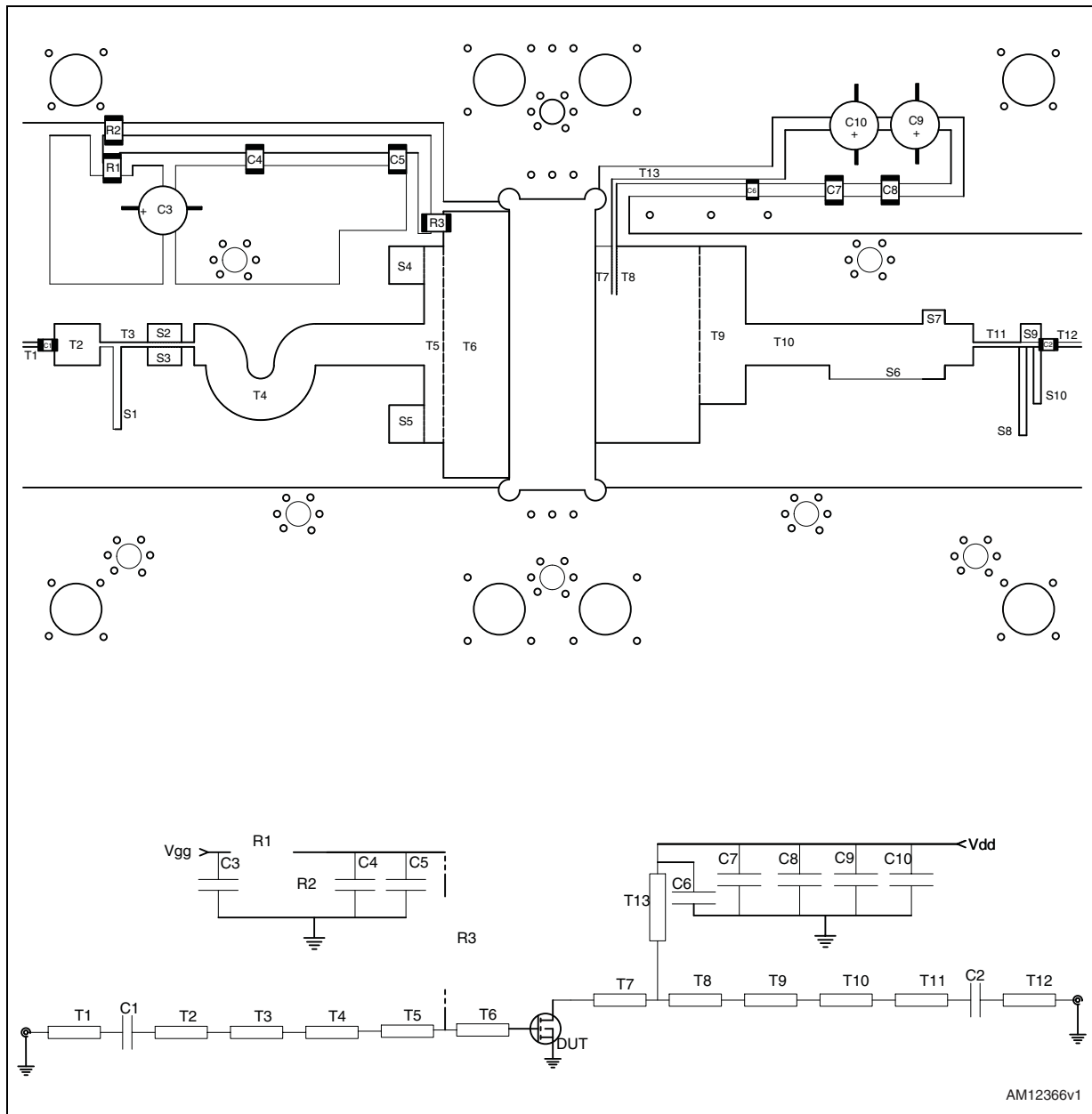

Table 7. Component list

Component	Description	Dimensions (X,Y)	Values
TL1	Stripline	L=0.111" W=0.022"	
TL2	Stripline	L=0.304" W=0.022"	
TL3	Stripline	L=1.74" W=0.196"	

Table 7. Component list (continued)

Component	Description	Dimensions (X,Y)	Values
TL4	Stripline	L=0.402" W=0.929"	
TL5	Stripline	L=0.100" W=0.929"	
TL6	Stripline	L=0.368" W=0.929"	
TL7	Stripline	L=1.136" W ₁ =0.196"	
TL8	Stripline	L=0.165" W=0.109"	
TL9	Stripline	L=0.341" W=0.022"	
TL10	Stripline	L=0.145" W=0.221"	
S1	Shim	L=0.048" W=0.091"	
S2	Shim	L=0.048" W=0.091"	
S3	Shim	L=0.105" W=0.091"	
S4	Shim	L=0.105" W=0.091"	
S5	Shim	L=0.050" W=0.361"	
S6	Shim	L=0.022" W=0.303"	
S7	Shim	L=0.105" W=0.069"	
S8	Shim	L=0.048" W=0.187"	
S9	Shim	L=0.158" W=0.069"	
S10	Shim	L=0.105" W=0.069"	
S11	Shim	L=0.105" W=0.069"	
S12	Shim	L=0.022" W=0.424"	
C1, C2	ATC100A300J chip capacitor		30 pF
C3	ATC100B101 chip capacitor		100 pF
C4	ATC100B910 chip capacitor		91 pF
C5	220 μ F, 63 V Electrolytic Capacitor		220 μ F
C6	ATC100B390 Chip Capacitor		39 pF
C7	ATC700B122JT Chip Capacitor		1200 pF
C8	1000 μ F, 63 V Electrolytic Capacitor		1000 μ F
C9	100 μ F, 100 V Electrolytic Capacitor		100 μ F
R1	CR1206-8W-102JB		1 k Ω
R2	CR1206-8W-202JB		2 k Ω
R3	CR1206-8W-501JB		50 Ω
Board material	Rogers Duroid 6010 Er = 10.2, Th = 0.64 mm	3x5 in ²	

Figure 8. Photo of the demonstration board

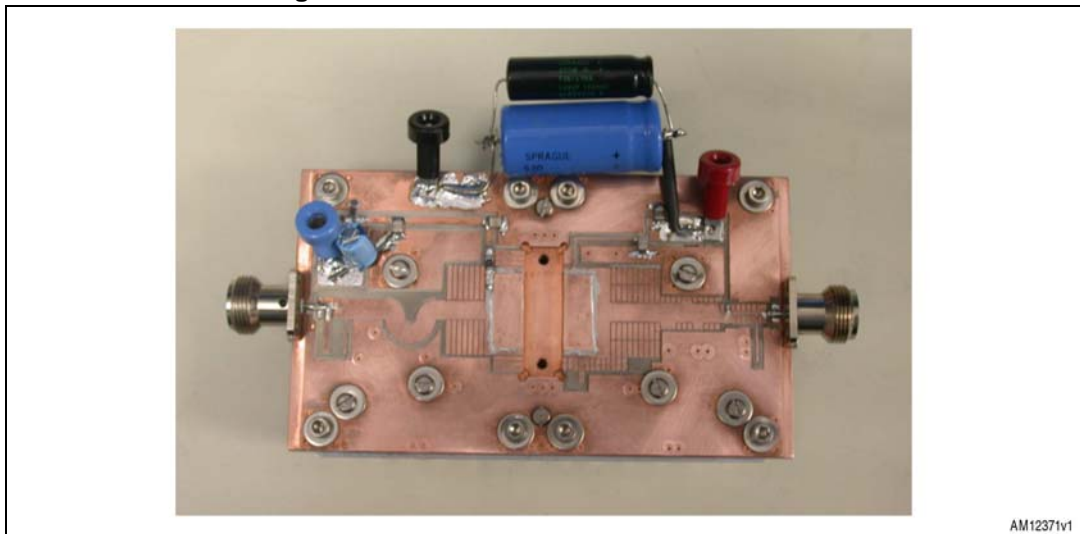

AM12371v1

6 Package mechanical data

In order to meet environmental requirements, ST offers these devices in different grades of ECOPACK® packages, depending on their level of environmental compliance. ECOPACK® specifications, grade definitions and product status are available at: www.st.com. ECOPACK® is an ST trademark.

Figure 9. Package dimensions

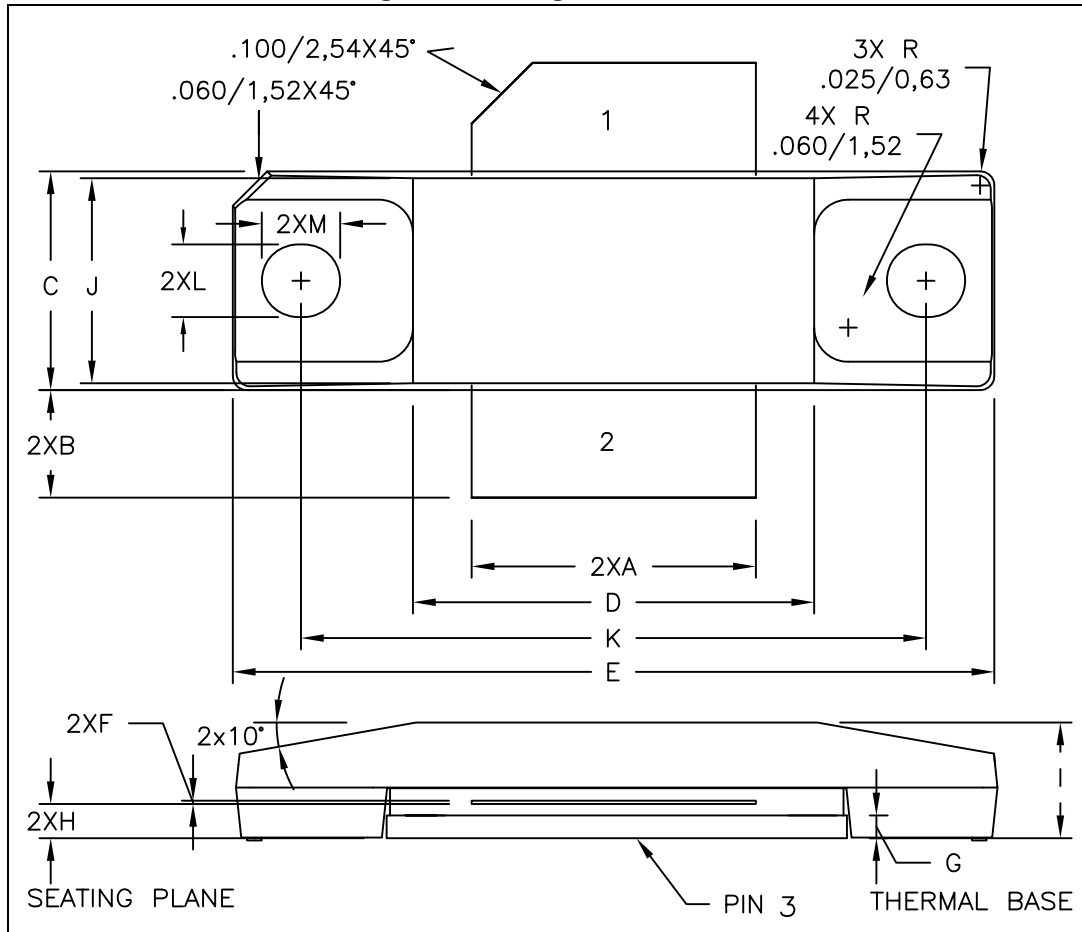

Table 8. STAC265B mechanical data

Dim.	mm.		
	Min.	Typ.	Max.
A	12.57		12.83
B	4.32		5.33
C	9.65		9.91
D	17.78		18.08
E	33.88		34.19
F	0.10		0.15
G		1.02	
H	1.45		1.70
I	4.83		5.33
J	9.27		9.52
K	27.69		28.19
L		3.23	
M		3.45	

7 Revision history

Table 9. Document revision history

Date	Revision	Changes
27-Jan-2012	1	First release.
06-Jun-2012	2	– Modified: Figure 7 – Added: Figure 8 – Updated the entire Table 7
24-Sep-2012	3	Updated title on the coverpage and Table 4 .
20-May-2014	4	Updated Table 8: STAC265B mechanical data . Minor text changes.

Please Read Carefully:

Information in this document is provided solely in connection with ST products. STMicroelectronics NV and its subsidiaries ("ST") reserve the right to make changes, corrections, modifications or improvements, to this document, and the products and services described herein at any time, without notice.

All ST products are sold pursuant to ST's terms and conditions of sale.

Purchasers are solely responsible for the choice, selection and use of the ST products and services described herein, and ST assumes no liability whatsoever relating to the choice, selection or use of the ST products and services described herein.

No license, express or implied, by estoppel or otherwise, to any intellectual property rights is granted under this document. If any part of this document refers to any third party products or services it shall not be deemed a license grant by ST for the use of such third party products or services, or any intellectual property contained therein or considered as a warranty covering the use in any manner whatsoever of such third party products or services or any intellectual property contained therein.

UNLESS OTHERWISE SET FORTH IN ST'S TERMS AND CONDITIONS OF SALE ST DISCLAIMS ANY EXPRESS OR IMPLIED WARRANTY WITH RESPECT TO THE USE AND/OR SALE OF ST PRODUCTS INCLUDING WITHOUT LIMITATION IMPLIED WARRANTIES OF MERCHANTABILITY, FITNESS FOR A PARTICULAR PURPOSE (AND THEIR EQUIVALENTS UNDER THE LAWS OF ANY JURISDICTION), OR INFRINGEMENT OF ANY PATENT, COPYRIGHT OR OTHER INTELLECTUAL PROPERTY RIGHT.

ST PRODUCTS ARE NOT DESIGNED OR AUTHORIZED FOR USE IN: (A) SAFETY CRITICAL APPLICATIONS SUCH AS LIFE SUPPORTING, ACTIVE IMPLANTED DEVICES OR SYSTEMS WITH PRODUCT FUNCTIONAL SAFETY REQUIREMENTS; (B) AERONAUTIC APPLICATIONS; (C) AUTOMOTIVE APPLICATIONS OR ENVIRONMENTS, AND/OR (D) AEROSPACE APPLICATIONS OR ENVIRONMENTS. WHERE ST PRODUCTS ARE NOT DESIGNED FOR SUCH USE, THE PURCHASER SHALL USE PRODUCTS AT PURCHASER'S SOLE RISK, EVEN IF ST HAS BEEN INFORMED IN WRITING OF SUCH USAGE, UNLESS A PRODUCT IS EXPRESSLY DESIGNATED BY ST AS BEING INTENDED FOR "AUTOMOTIVE, AUTOMOTIVE SAFETY OR MEDICAL" INDUSTRY DOMAINS ACCORDING TO ST PRODUCT DESIGN SPECIFICATIONS. PRODUCTS FORMALLY ESCC, QML OR JAN QUALIFIED ARE DEEMED SUITABLE FOR USE IN AEROSPACE BY THE CORRESPONDING GOVERNMENTAL AGENCY.

Resale of ST products with provisions different from the statements and/or technical features set forth in this document shall immediately void any warranty granted by ST for the ST product or service described herein and shall not create or extend in any manner whatsoever, any liability of ST.

ST and the ST logo are trademarks or registered trademarks of ST in various countries.

Information in this document supersedes and replaces all information previously supplied.

The ST logo is a registered trademark of STMicroelectronics. All other names are the property of their respective owners.

© 2014 STMicroelectronics - All rights reserved

STMicroelectronics group of companies

Australia - Belgium - Brazil - Canada - China - Czech Republic - Finland - France - Germany - Hong Kong - India - Israel - Italy - Japan - Malaysia - Malta - Morocco - Philippines - Singapore - Spain - Sweden - Switzerland - United Kingdom - United States of America

www.st.com

