

Low Noise GaAs MMIC Amplifier 3.5 - 7.0 GHz

Rev. V8

Features

- Noise Figure: 1.8 dB Typical
- Gain: 17 dB Typical
- Single Bias Supply
- DC Decoupled RF Input and Output

Description

The MAAM37000 die is a wide-band, low noise, MMIC amplifier. It includes two integrated gain stages and employs series inductive feedback to obtain excellent noise figure and a good 50 Ω , input and output impedance match over the entire frequency band. The MAAM37000 operates from a single +4 V supply.

The MAAM37000 performs well as a low noise amplifier in receive applications and as a driver or buffer amplifier where high gain, excellent linearity and low power consumption are important. Because of its wide bandwidth, the MAAM37000 can be used in numerous commercial and government system applications, such as TVRO, VSAT, missile guidance, and radar. The MAAM37000 is manufactured in-house using a reliable, 0.5-micron, GaAs MESFET process. This product is 100% RF tested to ensure compliance to performance specifications.

Ordering Information

Part Number	Package
MAAM37000	DIE

Die

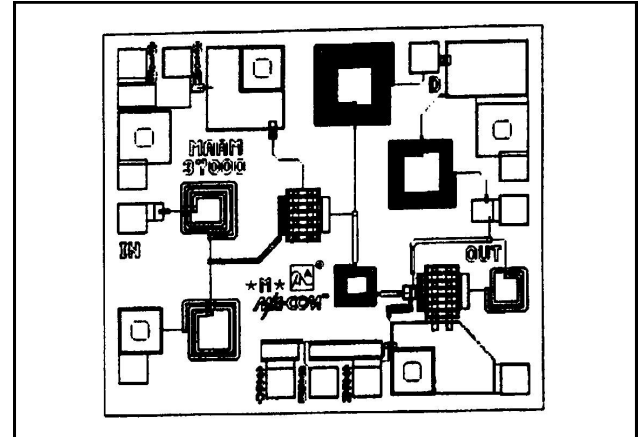

Schematic

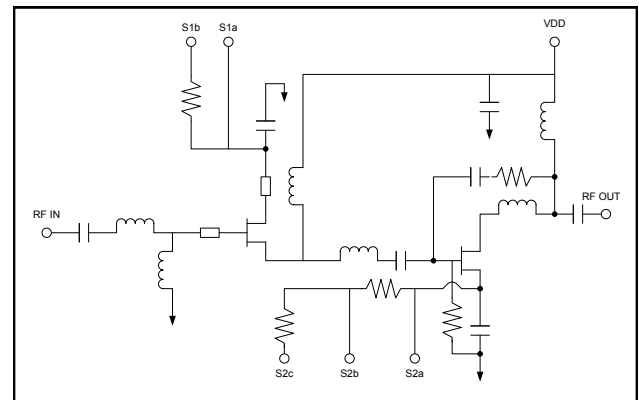

Absolute Maximum Ratings ¹

Parameter	Absolute Maximum
Voltage	+7 V
Input Power	+20 dBm
Operating Temperature	-55°C to +125°C
Storage Temperature	-65°C to +150°C

1. Exceeding any one or combination of these limits may cause permanent damage to this device.

Low Noise GaAs MMIC Amplifier 3.5 - 7.0 GHz

Rev. V8

Electrical Specifications: $T_A = 25^\circ\text{C}$, $Z_0 = 50 \Omega$, $V_{DD} = +4 \text{ VDC}$, $I_{DD} = 75 \text{ mA Typ, } 100 \text{ mA}$

Parameter	Units	Min	Typ.	Max
Gain ²	dB	15.0	17.0	—
Gain Flatness	dB		± 0.8	
Noise Figure ²	dB	—	1.8	2.8
Input VSWR	Ratio	—	1.5:1	—
Output VSWR	Ratio	—	1.5:1	—
Output Power at 1 dB Gain Compression	dBm	—	14	—
Third Order Intercept	dBm	—	24	—
Reverse Isolation	dB	—	35	—
Rth	$^\circ\text{C/W}$	—	85	—

2. 100% on-wafer tested.

Typical Performance Curves

Gain

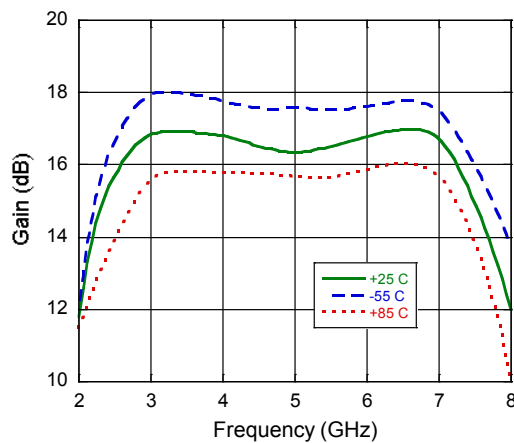

Noise Figure

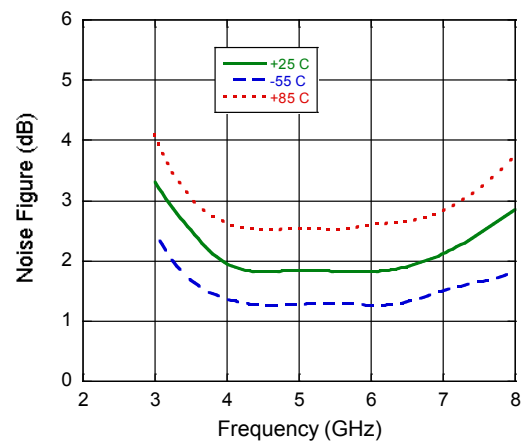

VSWR

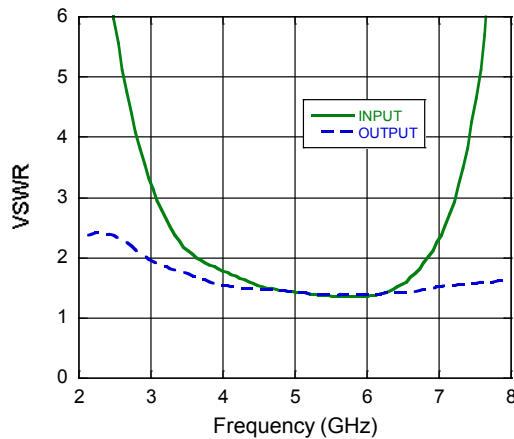

2

M/A-COM Technology Solutions Inc. (MACOM) and its affiliates reserve the right to make changes to the product(s) or information contained herein without notice. Visit www.macom.com for additional data sheets and product information.

For further information and support please visit:
<https://www.macom.com/support>

Typical Bias Configuration ^{3,4,5}

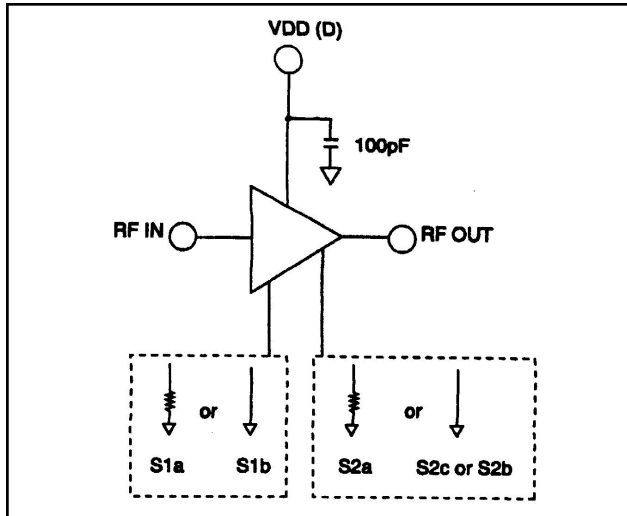

3. Nominal bias is obtained with on-chip resistors by grounding pads S1b and S2b.
4. Ground pads S1b and S2c for lower second state current.
5. Optional biasing can be obtained with off-chip resistors bonded from pads S1a and S2a to ground. Adjusting the bias can customize the performance to suit special requirements.

Outline Drawing

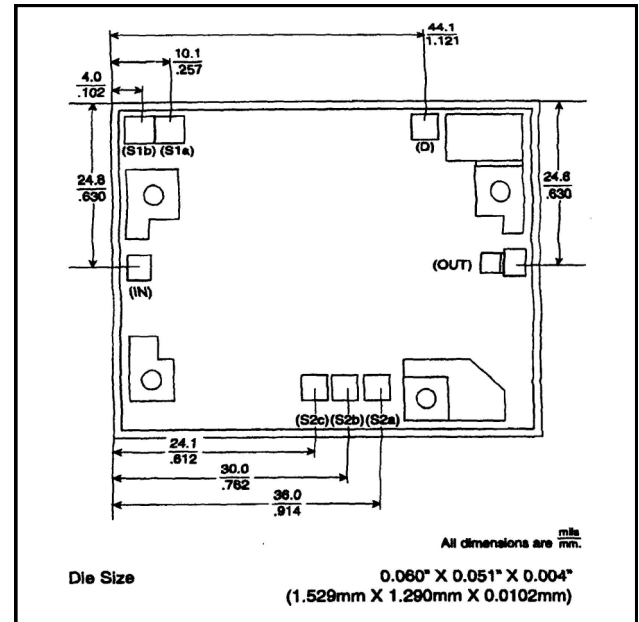

Handling Procedures

Permanent damage to the MAAM37000 may occur if the following precautions are not adhered to:

- A. Cleanliness - The MAAM37000 should be handled in a clean environment. DO NOT attempt to clean assembly after the MAAM37000 is installed.
- B. Static Sensitivity - All die handling equipment and personnel should comply with DOD-STD-1686 Class I.
- C. Transients - Avoid instrument and power supply transients while bias is connected to the MAAM37000. Use shielded signal and bias cables to minimize inductive pick-up.
- D. General Handling - DO NOT touch the surface of the die. It is recommended that the MAAM37000 die be handled along the long side with a sharp pair of tweezers.

Mounting

The MAAM37000 is back-metallized with Pd/Ni/Au (100/1, 000/30,000Å) metallization. It can be die-mounted using Au/Sn eutectic preforms or a thermally and electrically conductive epoxy. The attachment surface should be clean and flat.

Eutectic Die Attach:

- A. An 80/20 Au/Sn preform is recommended with a work surface temperature of approximately 255°C and a tool temperature of 265°C. When hot 95/5 nitrogen/hydrogen gas is applied, solder temperature should be approximately 290°C.
- B. DO NOT expose the MAAM37000 to a temperature greater than 320°C for more than 20 seconds. No more than 3 seconds of scrubbing should be required for attachment.

Epoxy Die Attach:

- A. Electrically conductive epoxy is required.
- B. Apply a minimum amount of epoxy and place the MAAM37000 into position. A thin epoxy fillet should be visible around the perimeter of the die.
- C. Cure epoxy per manufacturer's recommended schedule.

Bonding

- A. Ball or wedge bond with 1.0 mil diameter gold wire of 3.0 mil x 0.5 mil ribbon. Thermosonic bonding with a nominal stage temperature of 150°C and a ball bonding force of 40 to 50 grams or wedge bonding force of 18 to 22 grams is recommended. Ultrasonic energy and time should be adjusted to the minimum levels necessary to achieve reliable bonds.
- B. Bonds should be started on the die and terminated on the package.
- C. Bonding pads are 4.0 x 4.0 mils minimum.

M/A-COM Technology Solutions Inc. All rights reserved.

Information in this document is provided in connection with M/A-COM Technology Solutions Inc ("MACOM") products. These materials are provided by MACOM as a service to its customers and may be used for informational purposes only. Except as provided in MACOM's Terms and Conditions of Sale for such products or in any separate agreement related to this document, MACOM assumes no liability whatsoever. MACOM assumes no responsibility for errors or omissions in these materials. MACOM may make changes to specifications and product descriptions at any time, without notice. MACOM makes no commitment to update the information and shall have no responsibility whatsoever for conflicts or incompatibilities arising from future changes to its specifications and product descriptions. No license, express or implied, by estoppel or otherwise, to any intellectual property rights is granted by this document.

THESE MATERIALS ARE PROVIDED "AS IS" WITHOUT WARRANTY OF ANY KIND, EITHER EXPRESS OR IMPLIED, RELATING TO SALE AND/OR USE OF MACOM PRODUCTS INCLUDING LIABILITY OR WARRANTIES RELATING TO FITNESS FOR A PARTICULAR PURPOSE, CONSEQUENTIAL OR INCIDENTAL DAMAGES, MERCHANTABILITY, OR INFRINGEMENT OF ANY PATENT, COPYRIGHT OR OTHER INTELLECTUAL PROPERTY RIGHT. MACOM FURTHER DOES NOT WARRANT THE ACCURACY OR COMPLETENESS OF THE INFORMATION, TEXT, GRAPHICS OR OTHER ITEMS CONTAINED WITHIN THESE MATERIALS. MACOM SHALL NOT BE LIABLE FOR ANY SPECIAL, INDIRECT, INCIDENTAL, OR CONSEQUENTIAL DAMAGES, INCLUDING WITHOUT LIMITATION, LOST REVENUES OR LOST PROFITS, WHICH MAY RESULT FROM THE USE OF THESE MATERIALS.

MACOM products are not intended for use in medical, lifesaving or life sustaining applications. MACOM customers using or selling MACOM products for use in such applications do so at their own risk and agree to fully indemnify MACOM for any damages resulting from such improper use or sale.

5

M/A-COM Technology Solutions Inc. (MACOM) and its affiliates reserve the right to make changes to the product(s) or information contained herein without notice.
Visit www.macom.com for additional data sheets and product information.