

High Speed Analog Output Type 8-Pin Photocoupler PS8602

■ Features

- High supply voltage ($V_{CC} = 35\text{ V MAX.}$)
- High speed response ($t_{PHL}, t_{PLH} = 0.8\ \mu\text{ s MAX.}$)
- High isolation voltage ($BV = 5\ 000\text{ Vr.m.s.}$)
- TTL, CMOS compatible with a resistor

■ Package Dimensions (In millimeters)

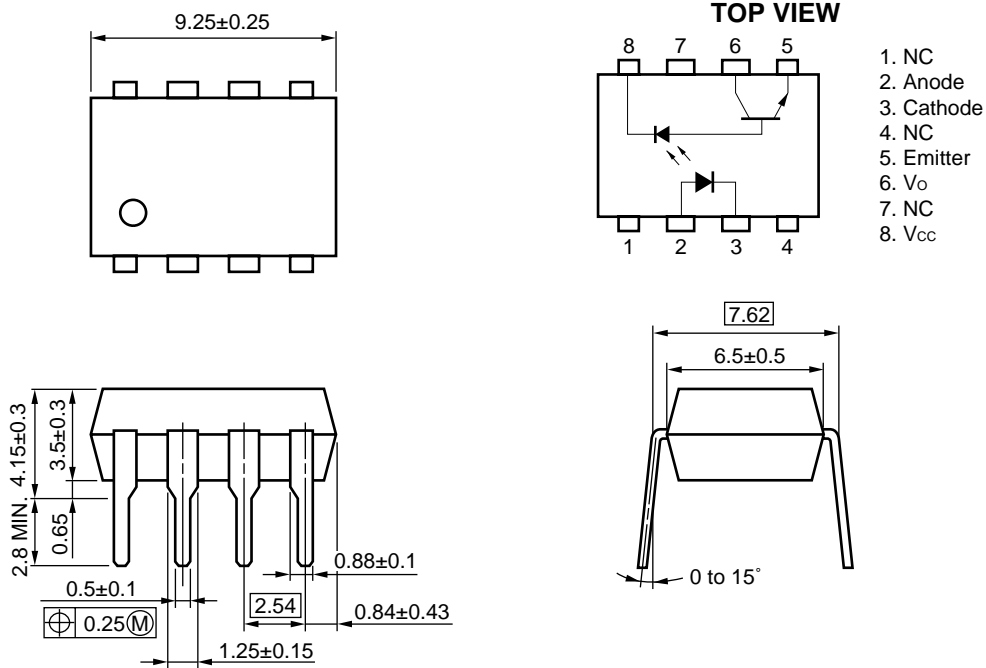

PS8602

■ Absolute Maximum Ratings $T_a = 25^\circ\text{C}$

Parameter		Symbol	Ratings	Unit
Diode	Forward Current	I_F	25	mA
	Reverse Voltage	V_R	5	V
	Power Dissipation	P_D	45	mW
Detector	Supply Voltage	V_{CC}	35	V
	Output Voltage	V_O	35	V
	Output Current	I_O	8	mA
	Power Dissipation	P_C	100	mW
Isolation Voltage ^{*1}		BV	5 000	Vr.m.s.
Operating Ambient Temperature		T_A	-55 to +100	$^\circ\text{C}$
Storage Temperature		T_{stg}	-55 to +150	$^\circ\text{C}$

*1 AC voltage for 1 minute at $T_A = 25^\circ\text{C}$, RH = 60 % between input and output.

■ Electrical Characteristics $T_a = 25^\circ\text{C}$

Parameter		Symbol	Conditions	MIN.	TYP. ^{*1}	MAX.	Unit
Diode	Forward Voltage	V_F	$I_F = 16\text{ mA}$		1.7	2.2	V
	Reverse Current	I_R	$V_R = 5\text{ V}$			10	μA
	Forward Voltage Temperature Coefficient	$\Delta V_F / \Delta T$	$I_F = 16\text{ mA}$		-1.6		mV/ $^\circ\text{C}$
	Terminal Capacitance	C_t	$V = 0\text{ V}$, $f = 1\text{ MHz}$		60		pF
Detector	High Level Output Current	$I_{OH(1)}$	$I_F = 0\text{ mA}$, $V_{CC} = V_O = 5.5\text{ V}$		3	500	nA
	High Level Output Current	$I_{OH(2)}$	$I_F = 0\text{ mA}$, $V_{CC} = V_O = 35\text{ V}$			100	μA
	Low Level Output Voltage	V_{OL}	$I_F = 16\text{ mA}$, $V_{CC} = 4.5\text{ V}$, $I_O = 1.2\text{ mA}$		0.1	0.4	V
	Low Level Supply Current	I_{CCL}	$I_F = 16\text{ mA}$, $V_O = \text{Open}$, $V_{CC} = 35\text{ V}$		50		μA
	High Level Supply Current	I_{CCH}	$I_F = 0\text{ mA}$, $V_O = \text{Open}$, $V_{CC} = 35\text{ V}$		0.01	1	μA
Coupled	Current Transfer Ratio	CTR	$I_F = 16\text{ mA}$, $V_{CC} = 4.5\text{ V}$, $V_O = 0.4\text{ V}$	15			%
	Isolation Resistance	R_{I-O}	$V_{I-O} = 1\text{ kV}_{bc}$	10^{11}			Ω
	Isolation Capacitance	C_{I-O}	$V = 0\text{ V}$, $f = 1\text{ MHz}$		0.7		pF
	Propagation Delay Time (H \rightarrow L) ^{*2}	t_{PHL}	$I_F = 16\text{ mA}$, $V_{CC} = 5\text{ V}$, $R_L = 1.9\text{ k}\Omega$		0.5	0.8	μs
	Propagation Delay Time (L \rightarrow H) ^{*2}	t_{PLH}	$I_F = 16\text{ mA}$, $V_{CC} = 5\text{ V}$, $R_L = 1.9\text{ k}\Omega$		0.3	0.8	μs
	Common Mode Transient Immunity at High Level Output ^{*3}	CMH	$I_F = 0\text{ mA}$, $V_{CM} = 400\text{ V}$ $R_L = 4.1\text{ k}\Omega$	-2 000			V/ μs
	Common Mode Transient Immunity at Low Level Output ^{*3}	CML	$I_F = 16\text{ mA}$, $V_{CM} = 400\text{ V}$ $R_L = 4.1\text{ k}\Omega$	2 000			V/ μs

PS8602

*1 Typical values at $T_A = 25\text{ }^\circ\text{C}$

*2 Test circuit for propagation delay time

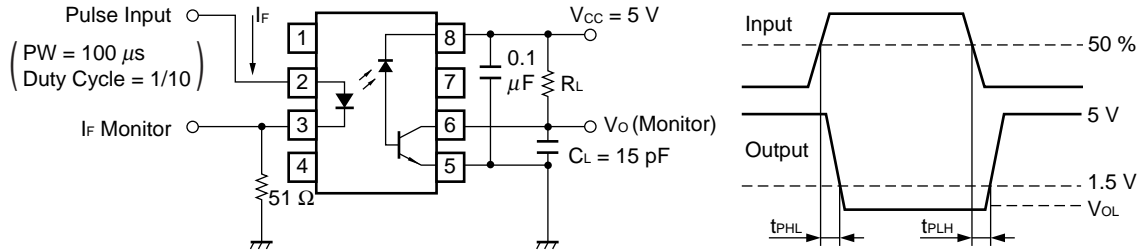

C_L includes probe and stray wiring capacitance

*3 Test circuit for common mode transient immunity

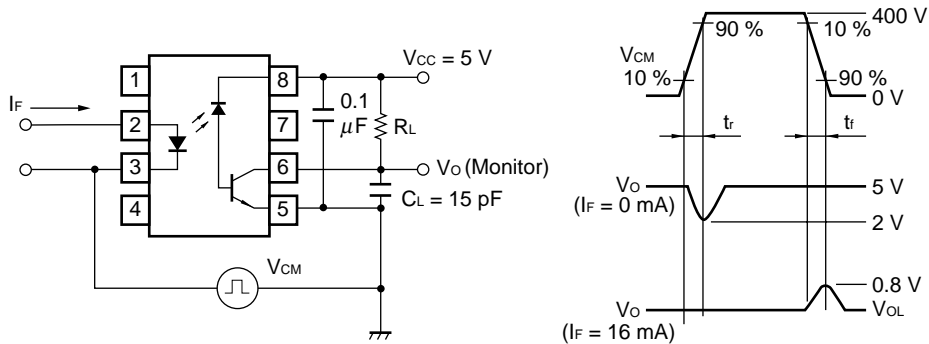

PS8602

■ Typical Characteristics (TA=25°C, unless otherwise specified)

MAXIMUM FORWARD CURRENT vs. AMBIENT TEMPERATURE

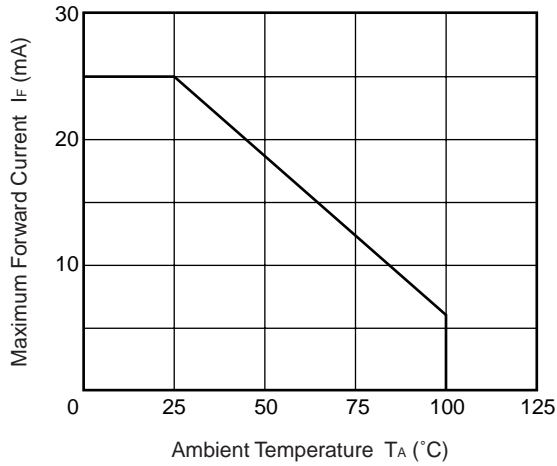

DETECTOR POWER DISSIPATION vs. AMBIENT TEMPERATURE

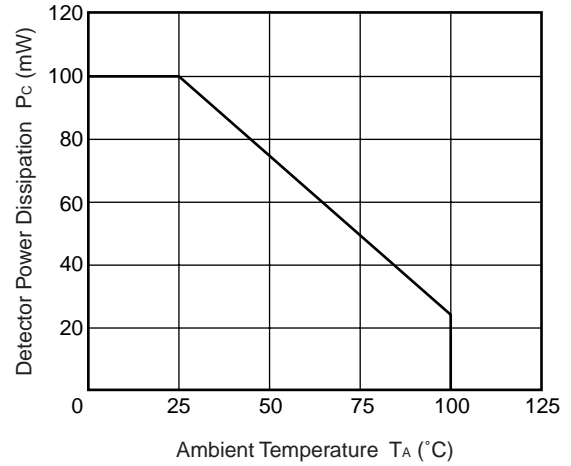

FORWARD CURRENT vs. FORWARD VOLTAGE

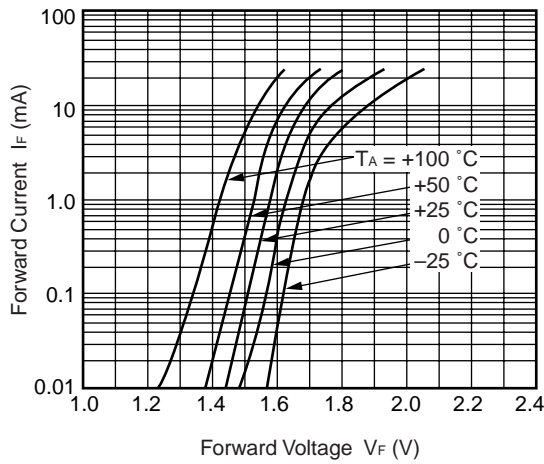

OUTPUT CURRENT vs. OUTPUT VOLTAGE

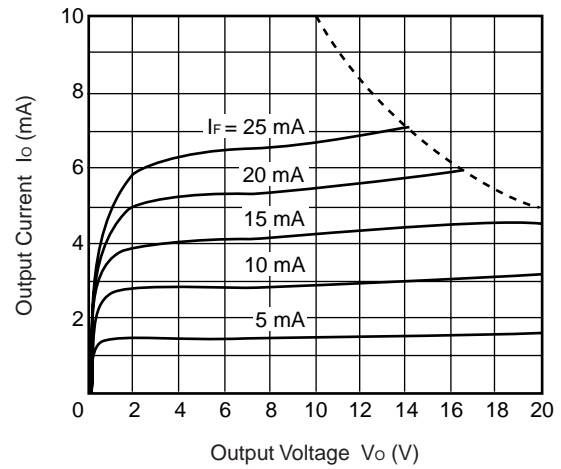

CURRENT TRANSFER RATIO vs. FORWARD CURRENT

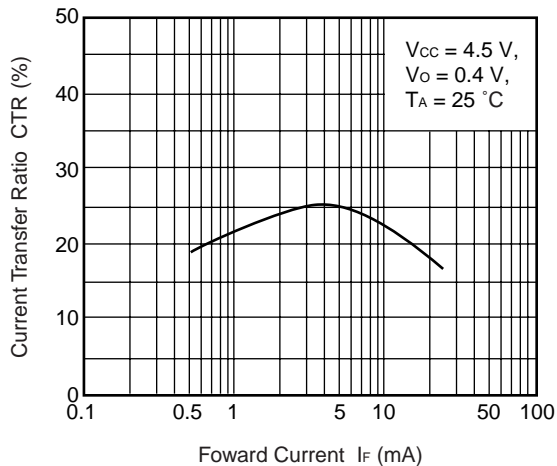

NORMALIZED CURRENT TRANSFER RATIO vs. AMBIENT TEMPERATURE

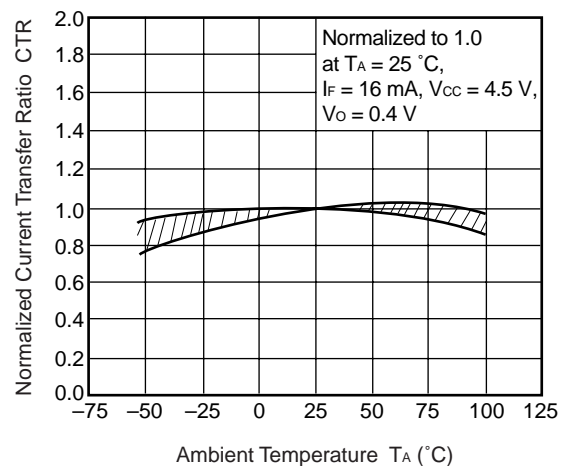

PS8602

OUTPUT VOLTAGE vs. FOWARD CURRENT

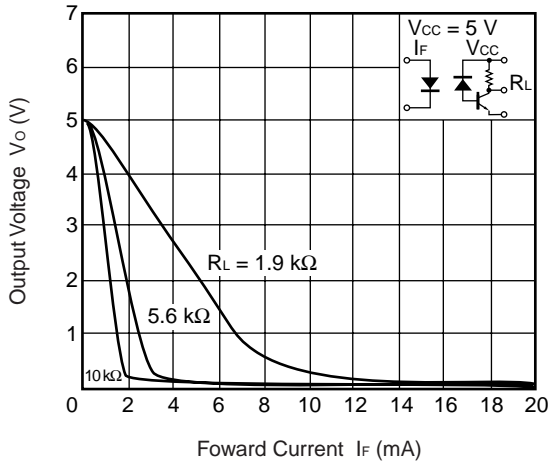

HIGH LEVEL OUTPUT CURRENT vs. AMBIENT TEMPERATURE

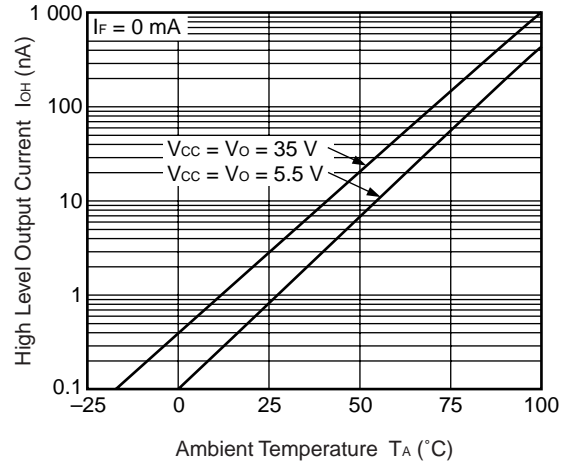

PROPAGATION DELAY TIME, vs. LORD RESISTANCE

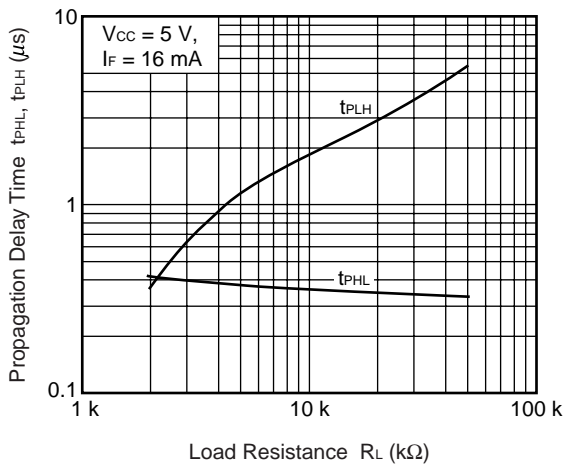

PROPAGATION DELAY TIME, vs. AMBIENT TEMPERATURE

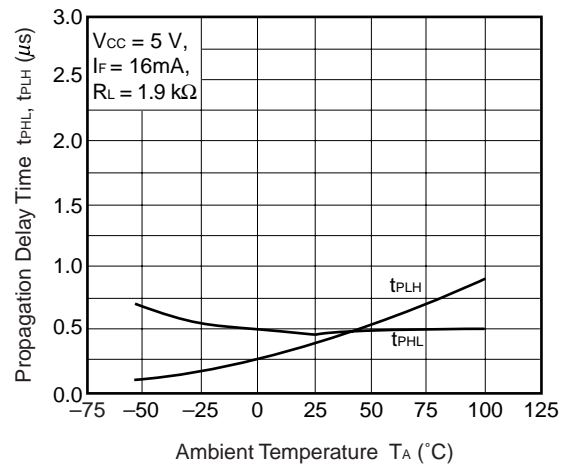

Remark The graphs indicate nominal characteristics.