

## General Purpose Transistors

### FEATURE

- High Voltage:  $V_{CEO} = -50\text{ V}$ .
- Epitaxial planar type.
- NPN complement: 2SC1623
- We declare that the material of product compliance with RoHS requirements.

#### Pb-Free package is available

RoHS product for packing code suffix "G"

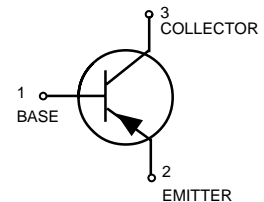
Halogen free product for packing code suffix "H"

Moisture Sensitivity Level 1



### DEVICE MARKING AND ORDERING INFORMATION

Device	Marking	Shipping
2SA812QLT1	M8	3000/Tape&Reel
2SA812RLT1	M6	3000/Tape&Reel
2SA812SLT1	M7	3000/Tape&Reel



### MAXIMUM RATINGS

Rating	Symbol	2SA812	Unit
Collector-Emitter Voltage	$V_{CEO}$	-50	V
Collector-Base Voltage	$V_{CBO}$	-60	V
Emitter-Base Voltage	$V_{EBO}$	-6	V
Collector current-continuoun	$I_c$	-150	mAdc

### THERMAL CHARATEERISTICS

Characteristic	Symbol	Max	Unit
Total Device Dissipation FR-5 Board, (1) $T_A=25^\circ\text{C}$ Derate above $25^\circ\text{C}$	$P_D$	200	mW
Thermal Resistance, Junction to Ambient	$R_{\theta JA}$	556	$^\circ\text{C/W}$
Total Device Dissipation Alumina Substrate, (2) $T_A=25^\circ\text{C}$ Derate above $25^\circ\text{C}$	$P_D$	200	mW
Thermal Resistance, Junction to Ambient	$R_{\theta JA}$	417	$^\circ\text{C/W}$
Junction and Storage Temperature	$T_j, T_{stg}$	-55 to +150	$^\circ\text{C}$

# General Purpose Transistors

**ELECTRICAL CHARACTERISTICS (TA=25°C unless otherwise noted)**

Characteristic	Symbol	Min	Typ	Max	Unit
----------------	--------	-----	-----	-----	------

**OFF CHARACTERISTICS**

Collector-Emitter Breakdown Voltage ( $I_C = -1\text{mA}$ )	$V_{(BR)CEO}$	-50	-	-	V
Emitter-Base Breakdown Voltage ( $I_E = -50\ \mu\text{A}$ )	$V_{(BR)EBO}$	-6	-	-	V
Collector-Base Breakdown Voltage ( $I_C = -50\ \mu\text{A}$ )	$V_{(BR)CBO}$	-60	-	-	V
Collector Cutoff Current ( $V_{CB} = -50\text{V}$ )	$I_{CBO}$	-	-	-0.1	$\mu\text{A}$
Emitter Cutoff Current ( $V_{BE} = -6\text{V}$ )	$I_{EBO}$	-	-	-0.1	$\mu\text{A}$

**ON CHARACTERISTICS**

DC Current Gain ( $I_C = -1\text{mA}, V_{CE} = -6.0\text{V}$ )	$h_{FE}$	120	-	560	
Collector-Emitter Saturation Voltage ( $I_C = -100\text{mA}, I_B = -10\text{mA}$ )	$V_{CE(sat)}$	-	-0.18	-0.3	V
Base -Emitter On Voltage $I_E = -1.0\text{mA}, V_{CE} = -6.0\text{V}$	$V_{BE}$	-0.58	-0.62	-0.68	V

**SMALL-SIGNAL CHARACTERISTICS**

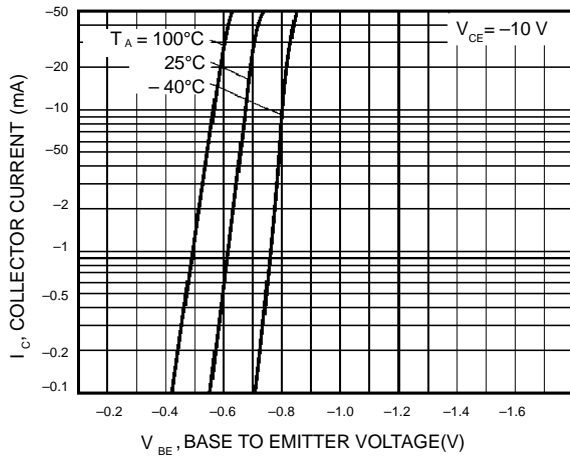
Current-Gain-Bandwidth Product ( $V_{CE} = -6.0\text{V}, I_E = -10\text{mA}$ )	$F_t$	-	180	-	MHz
Output Capacitance ( $V_{CE} = -10\text{V}, I_E = 0, f = 1.0\text{MHz}$ )	$C_{obo}$	-	4.5	-	pF

$h_{FE}$  Values are classified as follows

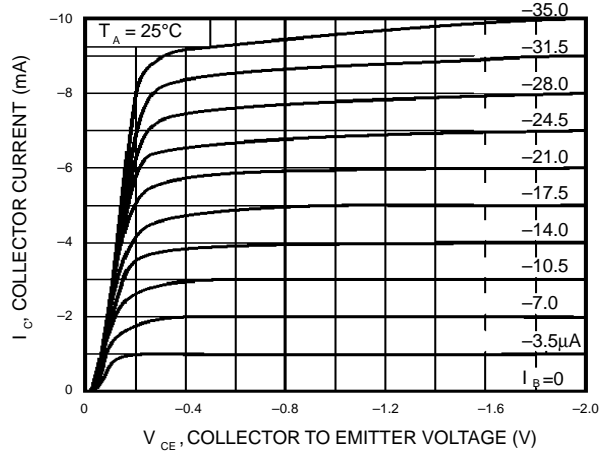
NOTE:	*	Q	R	S
	$h_{FE}$	120~270	180~390	270~560

**General Purpose Transistors**

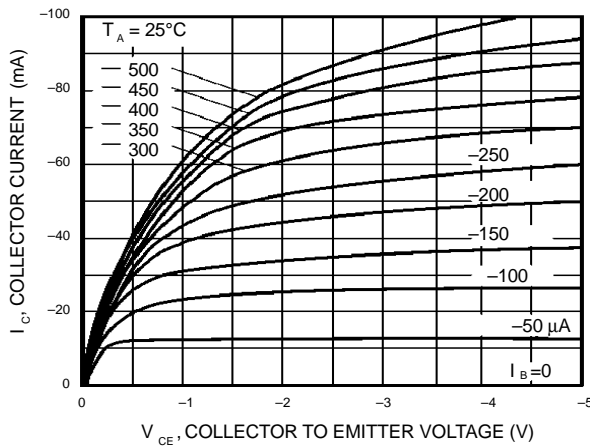
**Fig.1** Grounded emitter propagation characteristics



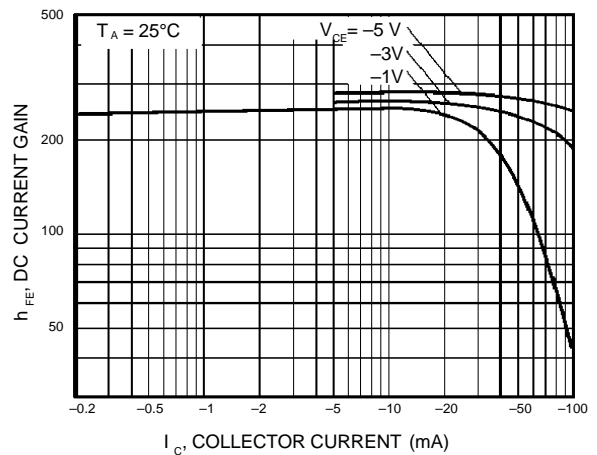
**Fig.2** Grounded emitter output characteristics(I)



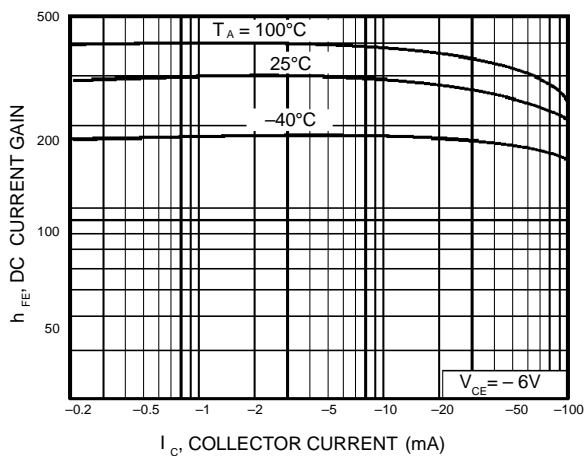
**Fig.3** Grounded emitter output characteristics(II)



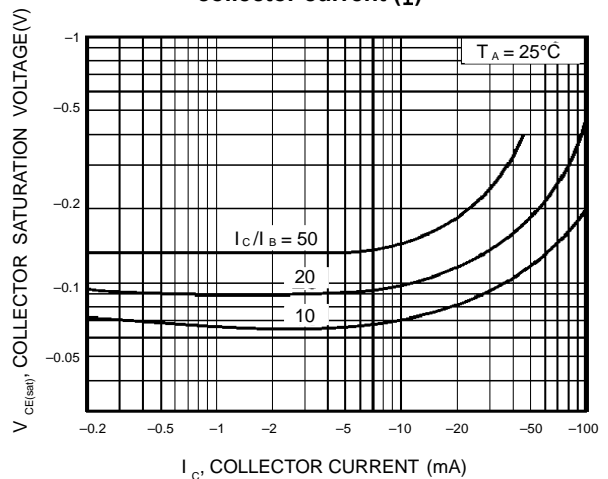
**Fig.4** DC current gain vs. collector current (I)



**Fig.5** DC current gain vs. collector current (II)

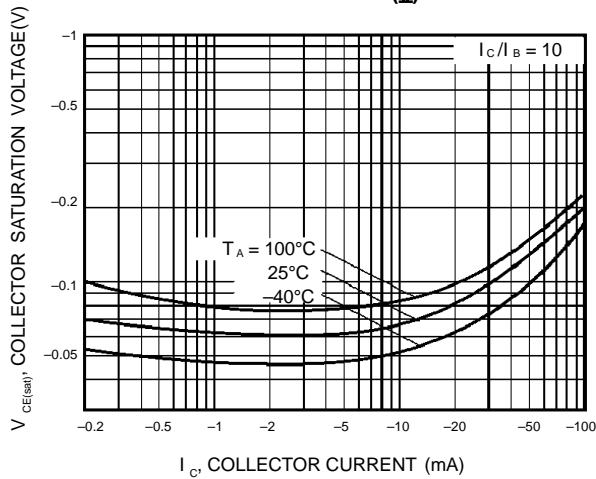


**Fig.6** Collector-emitter saturation voltage vs. collector current (I)

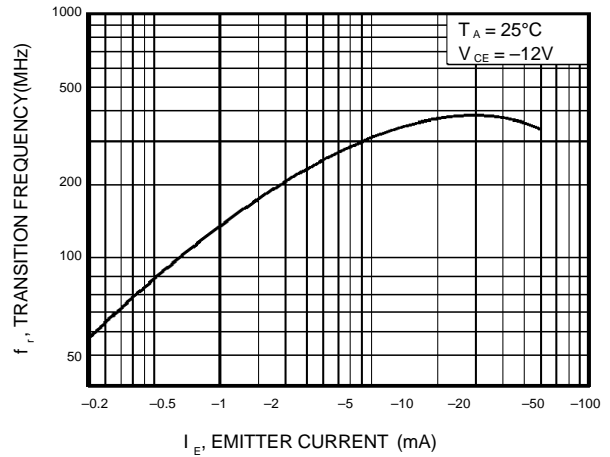


**General Purpose Transistors**

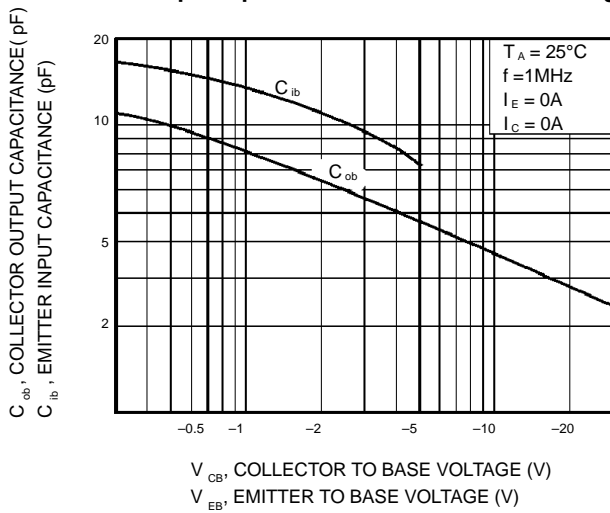
**Fig.7 Collector-emitter saturation voltage vs. collector current (I)**



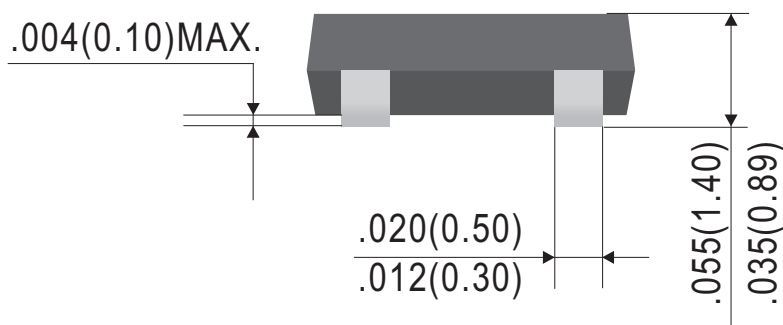
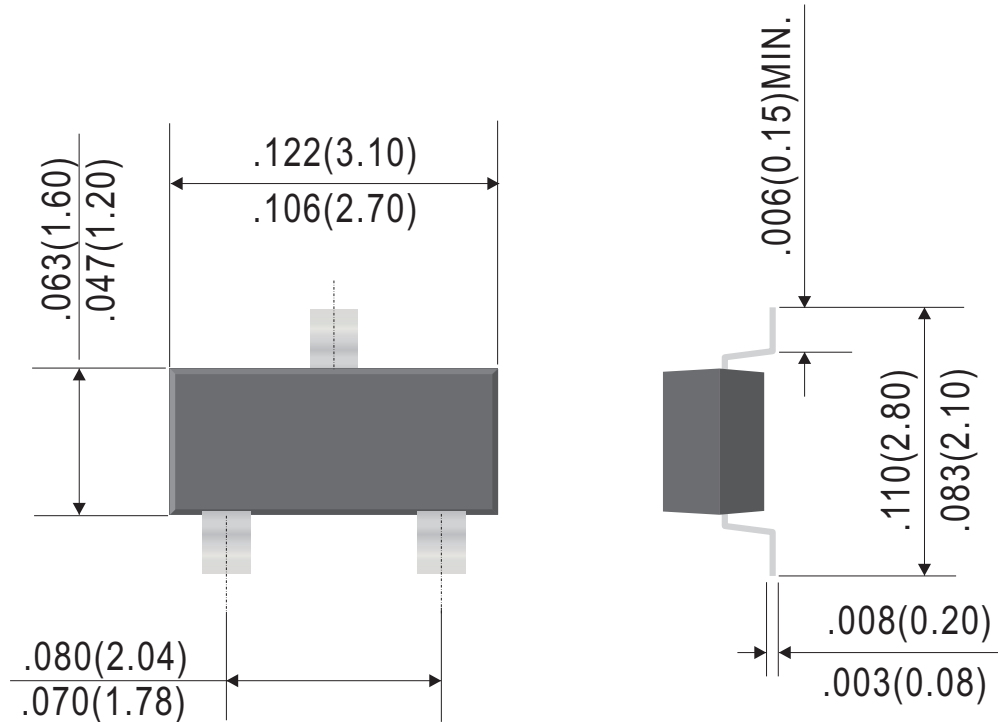
**Fig.8 Gain bandwidth product vs. emitter current**



**Fig.9 Collector output capacitance vs. collector-base voltage  
Emitter input capacitance vs. emitter-base voltage**



**SOT-23**



Dimensions in inches and (millimeters)

**Ordering Information:**

Device PN	Packing
2SA812 x <sup>(2)</sup> LT1 G <sup>(1)</sup> -WS	Tape&Reel: 3 Kpcs/Reel

Note: (1) RoHS product for packing code suffix "G" ; Halogen free product for packing code suffix "H"

(2) CLASSIFICATION OF hFE RANK

**\*\*\*Disclaimer\*\*\***

WILLAS reserves the right to make changes without notice to any product specification herein, to make corrections, modifications, enhancements or other changes. WILLAS or anyone on its behalf assumes no responsibility or liability for any errors or inaccuracies. Data sheet specifications and its information contained are intended to provide a product description only. "Typical" parameters which may be included on WILLAS data sheets and/ or specifications can and do vary in different applications and actual performance may vary over time. WILLAS does not assume any liability arising out of the application or use of any product or circuit.

WILLAS products are not designed, intended or authorized for use in medical, life-saving implant or other applications intended for life-sustaining or other related applications where a failure or malfunction of component or circuitry may directly or indirectly cause injury or threaten a life without expressed written approval of WILLAS. Customers using or selling WILLAS components for use in such applications do so at their own risk and shall agree to fully indemnify WILLAS Inc and its subsidiaries harmless against all claims, damages and expenditures.