

ESD9N5BU

**1-Line, Bi-directional, Ultra-low Capacitance,
Transient Voltage Suppressor**

<http://www.omnivision-group.com>

Descriptions

The ESD9N5BU is a transient voltage suppressors (TVS) which provide a very high level protection for sensitive electronic components that may be subjected to electrostatic discharge (ESD). It is designed to replace multiplayer varistors (MLV) in consumer equipments applications such as mobile phone, notebook, PAD, STB, LCD TV etc.

The ESD9N5BU was past ESD transient voltage up to $\pm 12\text{KV}$ (contact) according to IEC61000-4-2 and withstand peak current up to 3A for 8/20 μs pulse according to IEC61000-4-5.

The ESD9N5BU is available in DFN1006 package. Standard products are Pb-free and Halogen-free.



DFN1006-2L (Bottom View)

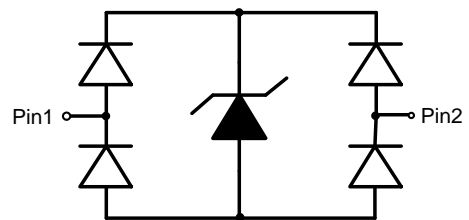

Circuit Diagram

Features

- Reverse stand-off voltage: $\pm 5.0\text{V}$ max.
- Transient protection for each line according to
 - IEC61000-4-2 (ESD) : $\pm 12\text{kV}$ (contact discharge)
 - : $\pm 15\text{kV}$ (air discharge)
 - IEC61000-4-4 (EFT) : 40A (5/50ns)
 - IEC61000-4-5 (surge) : 3A (8/20 μs)
- Ultra-low capacitance
- Low clamping voltage
- Low leakage current
- Small package

Applications

- Mobile phone
- PAD
- Notebook
- STB
- LCD TV
- Digital camera
- Other electronics equipments



* = Month (A~Z)
 U = Device code
Marking (Top View)

Order information

Device	Package	Shipping
ESD9N5BU-2/TR	DFN1006-2L	10000/Tape&Reel

Absolute maximum ratings

Parameter	Symbol	Rating	Unit
Peak pulse power (tp=8/20μs)	Ppk	54	W
Peak pulse current (tp=8/20μs)	Ipp	3	A
ESD voltage IEC61000-4-2 air	V _{ESD}	±15	KV
ESD voltage IEC61000-4-2 contact		±12	
Junction temperature	T _J	125	°C
Operating temperature	T _{OP}	-40~85	°C
Lead temperature	T _L	260	°C
Storage temperature	T _{sg}	-55~150	°C

Electronics characteristics (Ta=25°C, unless otherwise noted)

Parameter	Symbol	Condition	Min.	Typ.	Max.	Unit
Reverse stand-off voltage	V _{RWM}				±5.0	V
Reveres leakage current	I _R	V _{RWM} = 5V			1.0	μA
Reveres breakdown voltage	V _{BR}	I _T = 1mA	7.0	8.5	10.0	V
Clamping voltage ¹⁾	V _{CL}	I _{PP} = 16A, t _p = 100ns		35		V
Dynamic resistance ¹⁾	R _{DYN}			1.61		Ω
Clamping voltage ²⁾	V _{CL}	V _{ESD} = 6kV		27		V
Clamping voltage ²⁾	V _{CL}	V _{ESD} = 8kV		35		V
Clamping voltage ³⁾	V _C	I _{pp} =1A tp=8/20us		11.8	14	V
		I _{pp} =3A tp=8/20us		16	18	V
Junction capacitance	C _J	F=1MHz, V _R =0V		0.45	0.7	pF

Notes:

- 1) TLP parameter: Z₀ = 50Ω, t_p = 100ns, t_r = 2ns, averaging window from 60ns to 80ns. R_{DYN} is calculated from 4A to 16A.
- 2) Contact discharge mode, according to IEC61000-4-2.
- 3) Non-repetitive current pulse, according to IEC61000-4-5.

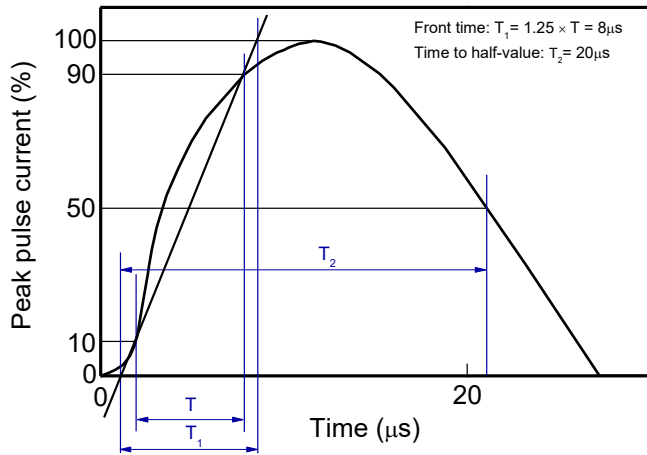
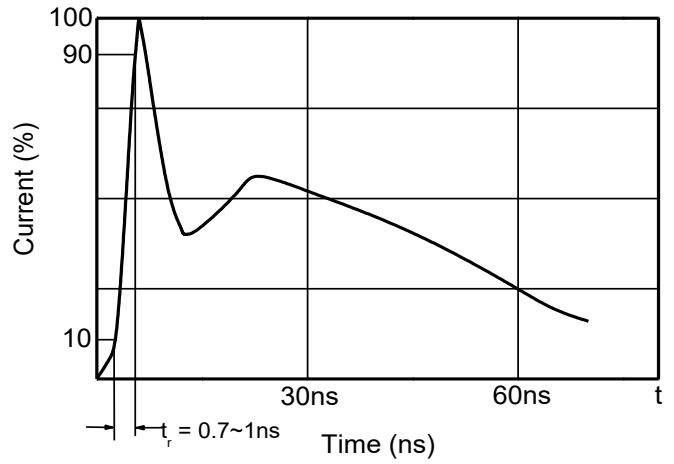
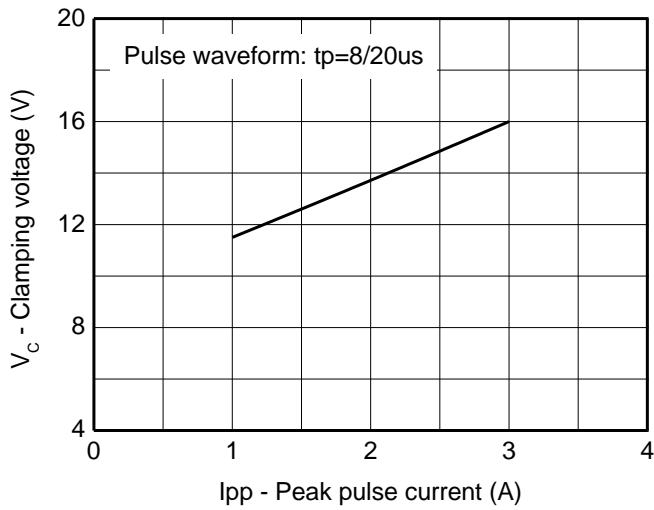
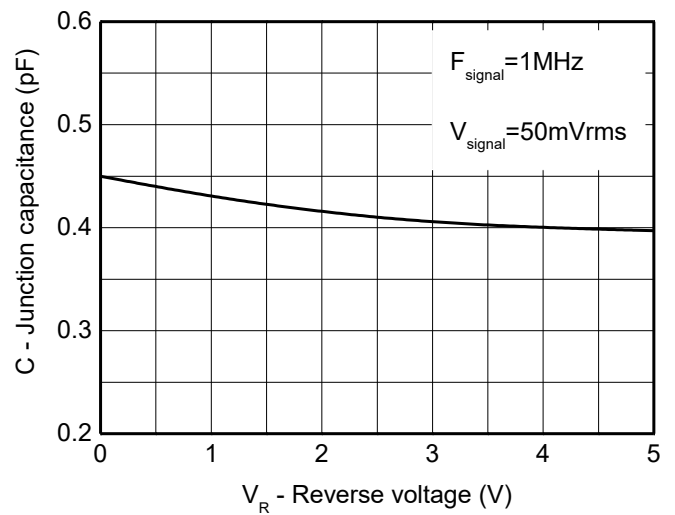
Typical characteristics ($T_A=25^\circ\text{C}$, unless otherwise noted)

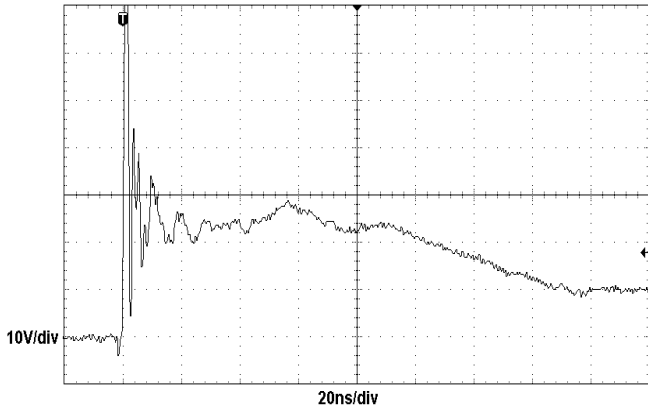
8/20 μs waveform per IEC61000-4-5

Contact discharge current waveform per IEC61000-4-2

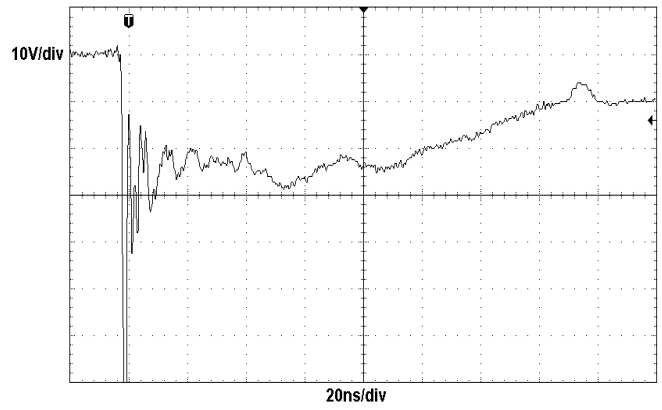
Clamping voltage vs. Peak pulse current

Capacitance vs. Reverse voltage

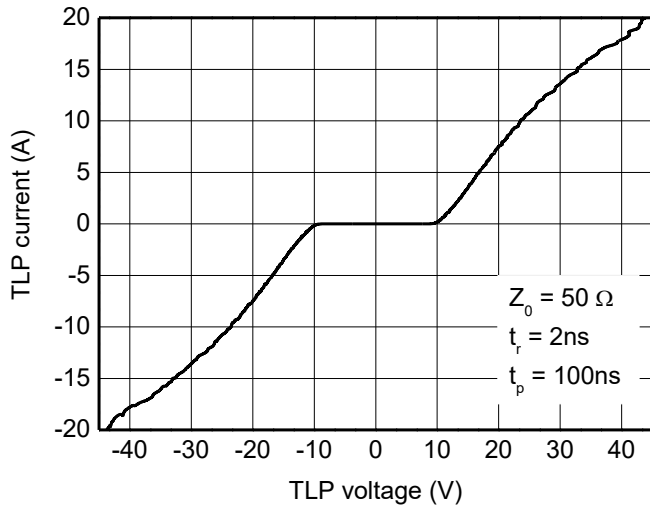
Typical characteristics ($T_A=25^\circ\text{C}$, unless otherwise noted)

ESD clamping
 (+8kV contact discharge per IEC61000-4-2)



ESD clamping
 (-8kV contact discharge per IEC61000-4-2)

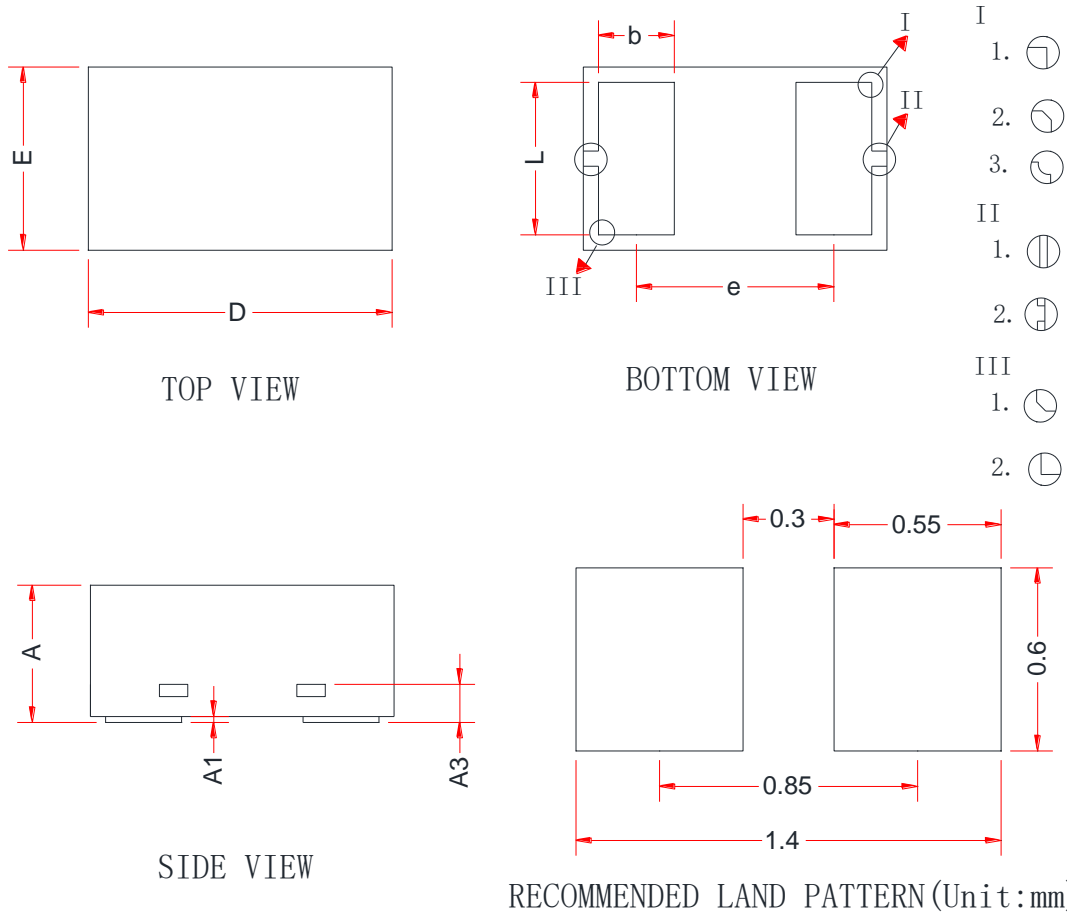

TLP Measurement

PACKAGE OUTLINE DIMENSIONS
DFN1006-2L

Symbol	Dimensions in Millimeters		
	Min.	Typ.	Max.
A	0.36	0.45	0.50
A1	0.00	0.02	0.05
A3	0.125 Ref.		
D	0.95	1.00	1.05
E	0.55	0.60	0.65
b	0.20	0.25	0.30
L	0.45	0.50	0.55
e	0.65 BSC		

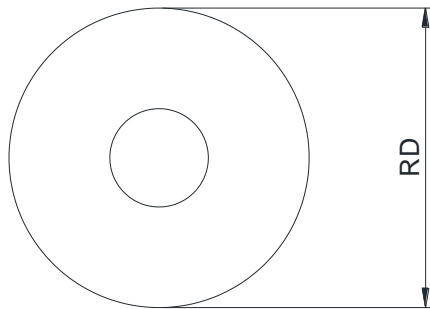
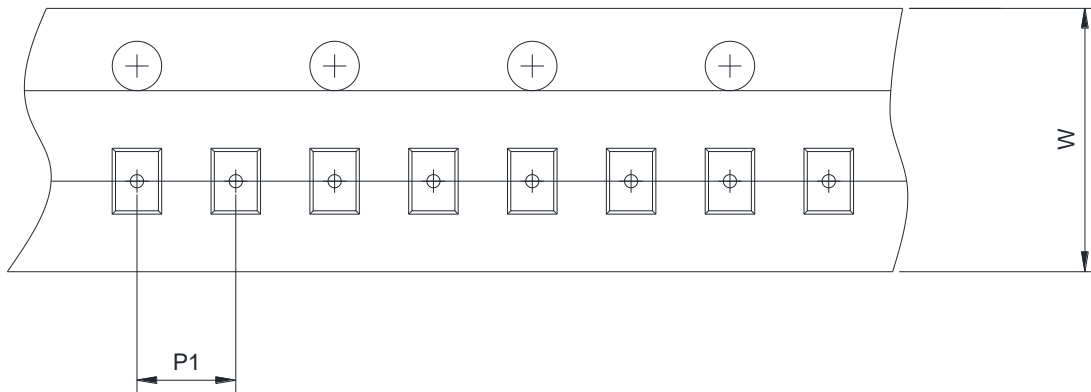
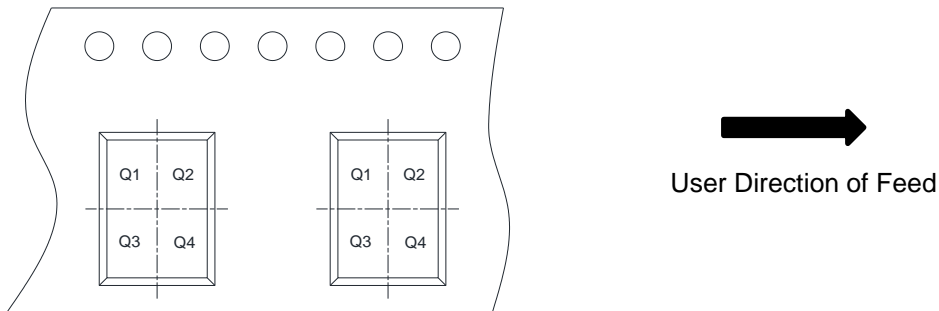
TAPE AND REEL INFORMATION
Reel Dimensions

Tape Dimensions

Quadrant Assignments For PIN1 Orientation In Tape

RD	Reel Dimension	<input checked="" type="checkbox"/> 7inch	<input type="checkbox"/> 13inch
W	Overall width of the carrier tape	<input checked="" type="checkbox"/> 8mm	<input type="checkbox"/> 12mm <input type="checkbox"/> 16mm
P1	Pitch between successive cavity centers	<input checked="" type="checkbox"/> 2mm	<input type="checkbox"/> 4mm <input type="checkbox"/> 8mm
Pin1	Pin1 Quadrant	<input checked="" type="checkbox"/> Q1	<input checked="" type="checkbox"/> Q2 <input type="checkbox"/> Q3 <input type="checkbox"/> Q4