

Product Specification

GOODARK Type (Solar Diode)

MBRB1545

Construction : Schottky Barrier Rectifier

Application : For General Purpose

(Manufacturer) :

Suzhou Goodark Electronics Co.,Ltd

Prepared on May. 10th, 2011

Prepared: R & D Department

Approva: QRA Department

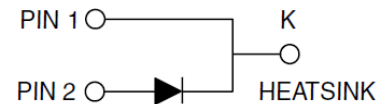
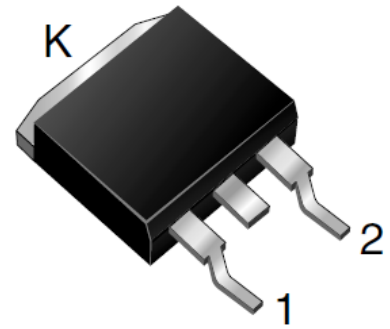
**SCHOTTKY BARRIER RECTIFIER****15 AMPERES****45 VOLTS****0.54V(15A Type)/Low Vf Schotty**

CONTENTS

1. Package Outline
2. Marking
3. Features& Mechanical Characteristics
4. Maximum Ratings and Electrical Characteristics
5. Rating and characteristic Curves
6. Packing Specification PACKAGING SPECIFICATION
7. Description of Box Label

1. Package Outline (TO263)

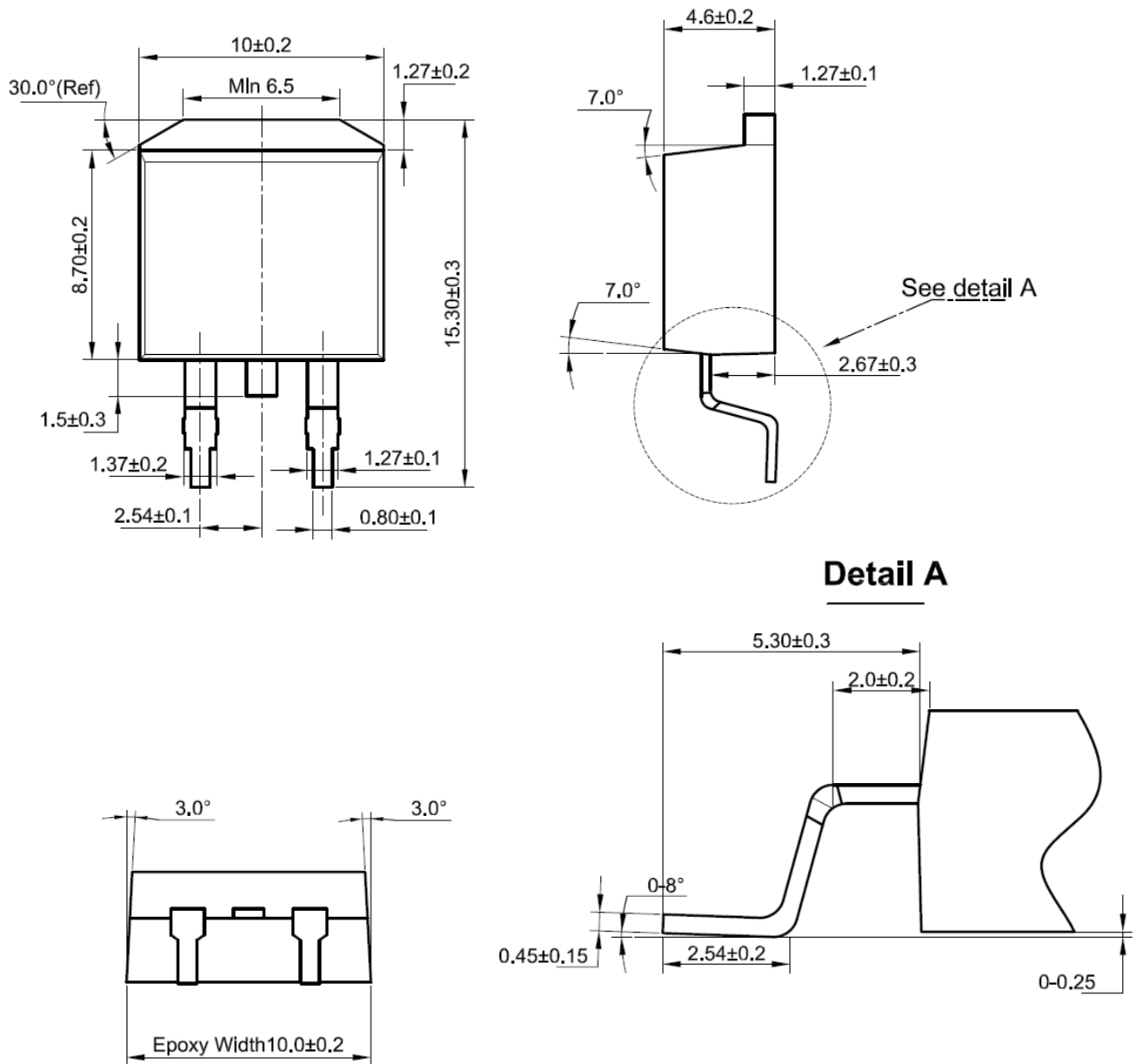

UNIT:mm

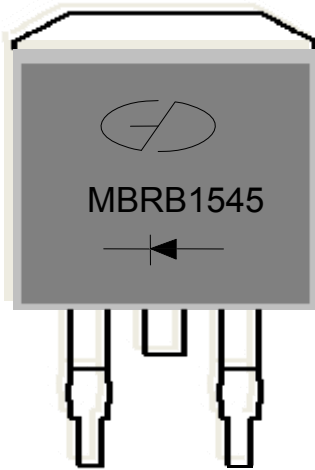

Lead Frame Material : Copper Plating: Pure Tin Plating

2.MARKING



1. Part Name : MBRB1545
2. Logo Mark: 
3. Polarity: 



3.Features& Mechanical Characteristics

Features

- Plastic package has underwriters Laboratory Flammability Classification 94V-0
- For surface mounted application
- Metal of silicon rectifier, majority carrier conduction
- Low forward voltage, high efficiency
- Guarding for over voltage protection
- For use in low voltage, high frequency inverters,
- Free wheeling, and polarity protection applications

Mechanical Characteristics

- Case: Epoxy, Molded
- Weight: 1.4grams (approximately)
- Finish: All External Surfaces Corrosion Resistant and Terminal Leads are Readily Solderable
- Lead Temperature for Soldering Purposes: 260°C Max.for10 sec
- Shipped 50 units per plastic tube or tape reel packing 800/reel

4.Maximum Ratings and Electrical Characteristics

MAXIMUM RATINGS and ELECTRICAL CHARACTERISTICS(TC=25°C unless otherwise moted)						
PARAMETER	TEST CONDITIONS		SYMBOL	MBRB1545	UNIT	
Maximum repetitive peak reverse voltage			VRRM	45	V	
Working peak reverse voltage			VRWM	45	V	
Maximum DC blocking voltage			VDC	45	V	
Maximum average forward rectified current at Tc=105°C total device per diode			IF(AV)	15	A	
Peak forward surge current 8.3ms single half sine-wave superimposed on rated load per diode			IFSM	250	A	
Peak repetitive reverse current per leg at tp=2.0us , 1KHz			IRRM	1.0	A	
Voltage rate of change (rated VR)			DV/dt	10000	V/us	
Operating junction temperature range			TJ	—55 to+150	°C	
Storage temperature range			TSTG	—55 to+150	°C	
Maximum instantaneous forward voltage per leg	IF=15A IF=15A	TC=25°C TC=125°C	VF	0.57 0.49	V	
Maximum reverse current per leg at working peak Reverse voltage			TJ=25°C TJ=100°C	IR	200 15	uA mA

Thermal Characteristics Ta=25°C unless otherwise noted

Symbol	Parameter	Max	Unit
RθJC	Thermal Resistance, Junction to Case per Leg	2.0	°C /W

Note:

1. Pulse test:300us pulse width, duty cycle=2%



5. Rating and Characteristic Curves

($T_c=25^\circ\text{C}$ Unless otherwise noted)

($T_c=25^\circ\text{C}$ unless otherwise noted)

Fig. 1 – Forward Current Derating Curve

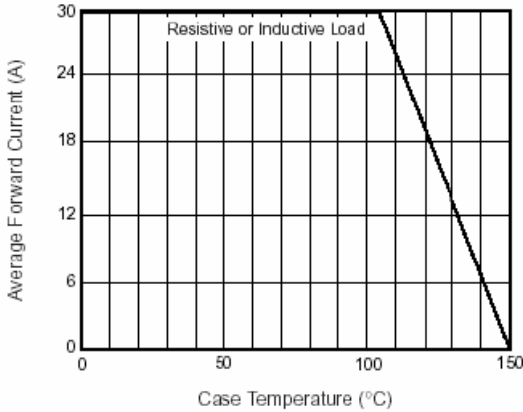

Fig. 2 – Maximum Non-Repetitive Peak Forward Surge Current Per Leg

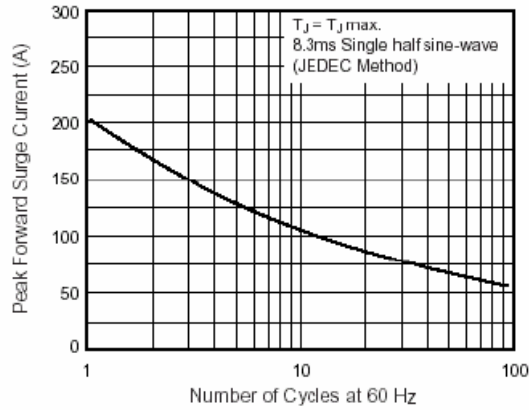

Fig. 3 – Typical Instantaneous Forward Characteristics Per Leg

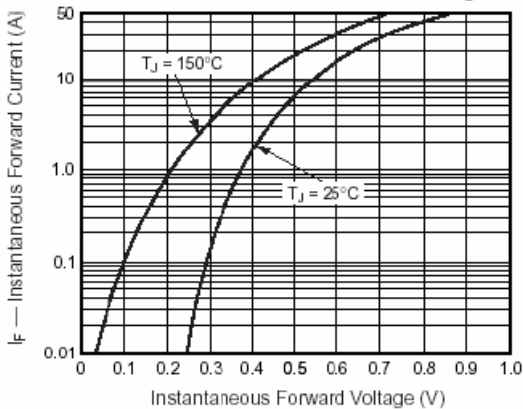

Fig. 4 – Typical Reverse Characteristics Per Leg

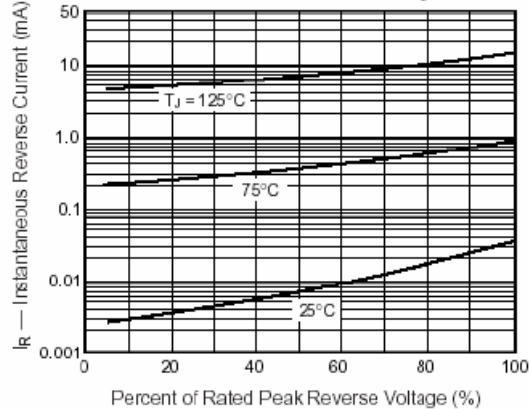

Fig. 5 – Typical Junction Capacitance Per Leg

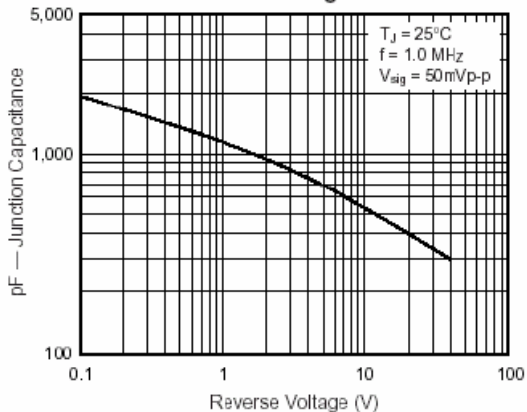
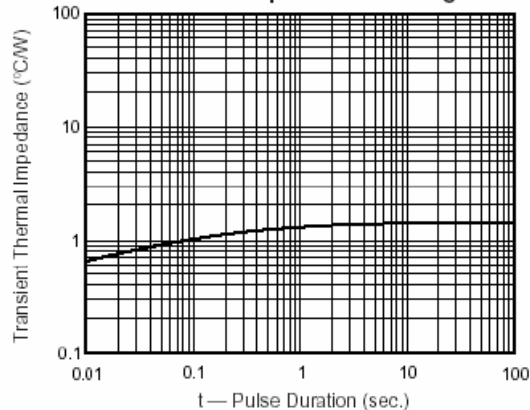





Fig. 6 – Typical Transient Thermal Impedance Per Leg



6. Packing Specification

6.1 Tube packing



	
1) Tube : 50units	2) Inner Box: 20 tube(1000units)
	
3) Outer Box: 10 inner box (10,000units)	

6.2 Tape&reel packing

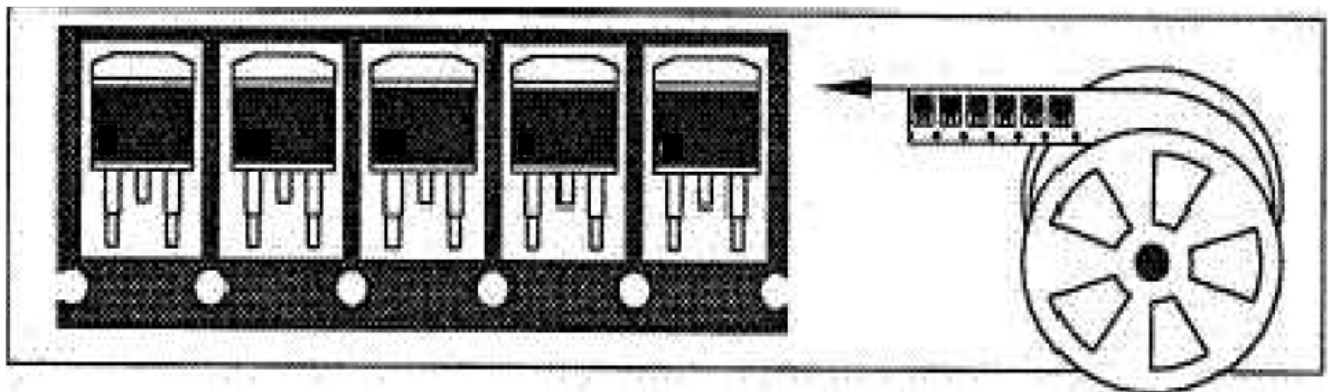
Packing size:800 /reel(13' reel)



7. DESCRIPTION of BOX LABEL

	<p>TYPE: Q'TY: P/O NO: LOT NO:</p>
<p>1) Inner Box Label</p>	<p>2) Inner Box Label</p>
	<p>TYPE: Q'TY: P/O NO:</p>
<p>3) Outer Box Label</p>	<p>4) Outer Box Label</p>